

30 CVEREL

THE WORLD IN A CLICK

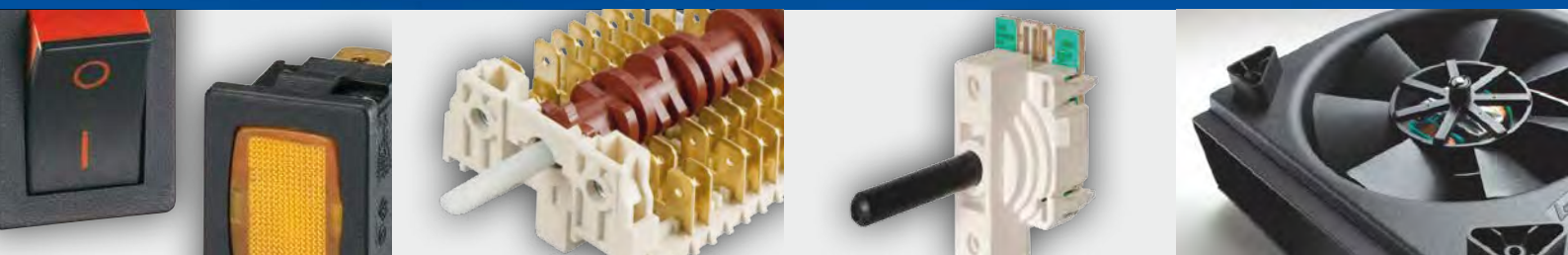

C A T A L O G U E



Dreefs

 **SIGNAL LUX**

givem

M MOLVENO

 **KAUTT & BUX**

30 **CVEREL**

THE WORLD IN A CLICK

C A T A L O G U E

Dreefs

 **SIGNAL LUX**

giwem

M MOLVENO

 **KAUTT & BUX**



Who is Everel

Everel is a leading manufacturer and supplier of electromechanical components for household appliances and automotive industry.

Through its own brands (Molveno, Dreefs, Giem Kautt&Bux and Signal Lux), Everel offers a wide range of products: switches, indicator lights, selectors, motors and heating elements, ventilation units, encoders, sub-assemblies.

Innovation, quality and customization are the values Everel relies on to satisfy customers and win the competition on the global market. Everel is recognised for its consolidated experience in production, its daily commitment to customer needs and its sound innovation capability. These are the milestones that make Everel a market leader, capable of satisfying the most challenging market requirements.

Everel: a customer driven company.



Foundation of
A.Cometti Company, an
electromechanical industry in
Caprino Veronese (near Verona)

1909

1978

Foundation of
Molveno Cometti S.p.A.

Construction of new production
plant in Lipova (Romania)

1986

1987

Establishment of holding

Acquisition of german company
Kautt&Bux

1994

1998

Acquisition of german
company **Dreefs**

History of Everel

Everel represents over 100 years of excellence in the field of electromechanical components for the appliance industry.

Born with the name Cometti, during this long journey it changed name several times (Vemer, Siber, ...) as a result of mergers and acquisitions, and in 2007 it came to the new brand Everel, which includes all formers.

The high know-how and experience gained by the Company have always been placed at the service of customers to develop new solutions and new technologies.

Transfer of Headquarters to
Valeggio sul Mincio (Verona)

1999

Introduction
of **Everel** brand

2007

2006

Acquisition of Italian company
Signal Lux

2010

Transfer of majority
to Secondlife srl

Acquisition of Mec-tronic brand

2013

2017

Everel Celebrates
the 30th anniversary

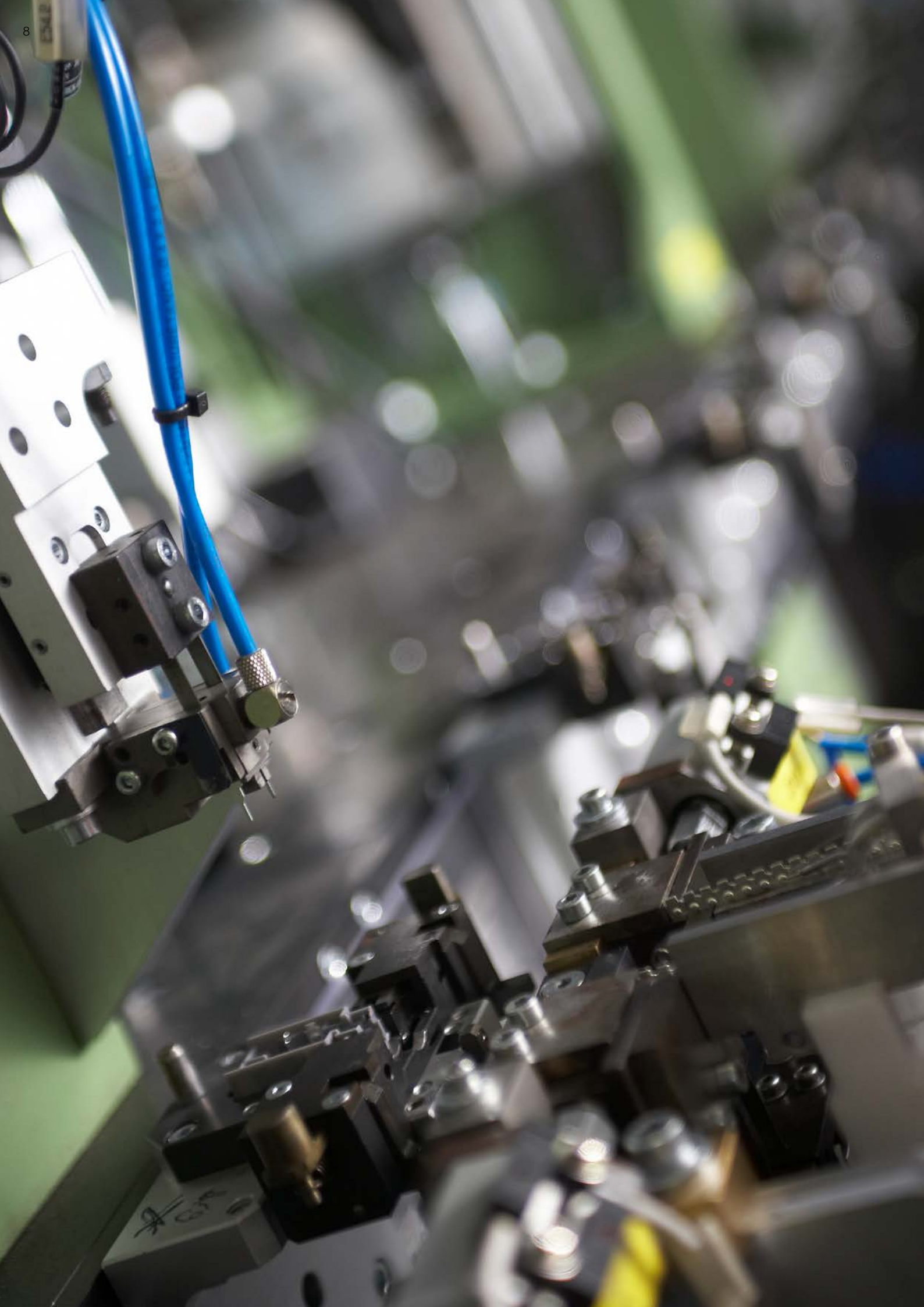

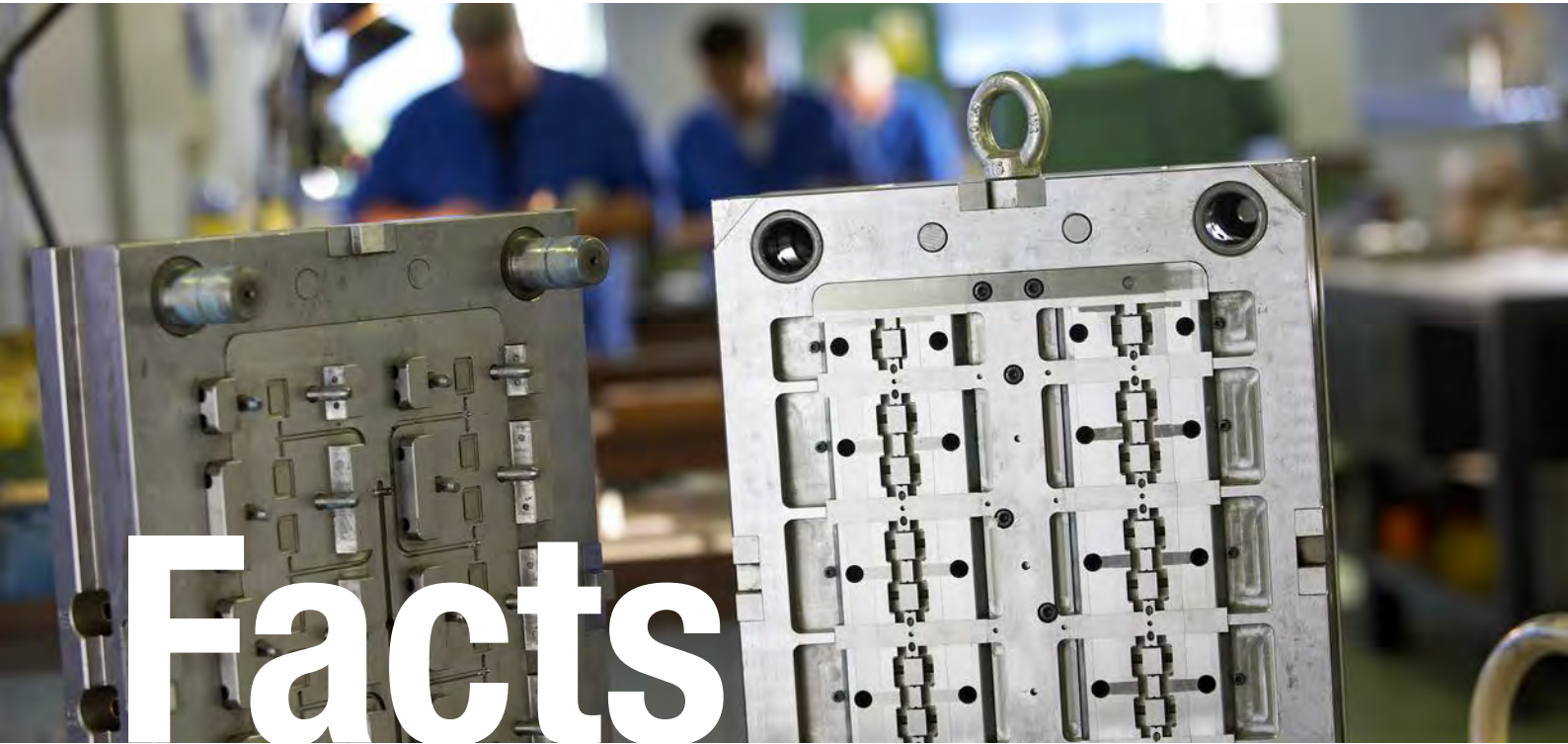

Facts

Key Competences and high level Capabilities

R&D

Qualified senior and junior technicians are dedicated to the development of technological innovations to improve products and processes.

Testing / Quality

Thousands of daily checks to ensure product reliability; during the years 89 international patents and 36 trademarks have been registered, they are the tangible measure of their commitment to this industry.

Sales, Marketing and Administration

Quality and efficiency are the values Everel relies on to satisfy tomorrow's customers in the international market, approached with the philosophy "Think global, Play local".

Production

From push-button switches to signal lights, from encoders to power rotary switches and cooling fans of any shape (centrifugal axial to axial/tangential) rocker switches, plug-in connectors, and keyboards, circuit boards and water resistant rocker switches, ventilation units and EC brushless motors.

Every year Everel production exceeds **120 million** items.

Everel portfolio includes fully automated production lines and moulding/punching core competences.



Customer

Wide Product Portfolio

Everel portfolio, with its brands Molveno, Giem, Dreefs, Kautt&Bux and Signal Lux, includes more than 7000 products. The home appliance market is the main area which Everel is focused on, designing and manufacturing electromechanical components and solutions for appliances. Everel is partner of the major worldwide appliance manufacturers.

Reliability

Our quality department makes strict controls on the production processes and on the end products in order to guarantee the absolute reliability of every single article.

All Everel items are covered by international approvals, which validate the quality and the compliance to the most important regulations.

Our products are made using materials and procedures according to RoHS 2011/65/EU directive, concerning restrictions on the use of hazardous substances and on the waste handling of electric and electronic devices.

Everel Group's quality management system is certified with ISO9001:2000.

100+ Years of Experience

The unique experience in the electromechanical industry makes Everel a leader supplier for household appliance and industrial equipment manufacturers.

Over the years our company expanded its product portfolio to meet the needs of different markets, increasing its business as well as its own experience.

Driven by Passion and Values

Everel looks at the future as an opportunity, offering highly pioneering and customized solutions. Customer satisfaction is the most important achievement and it is the reason why the company is fully committed to meet the client needs.

Innovation & Co-development

Every single product is featured by a never ending innovation process. Our R&D team works directly with customers which are completely involved in the product engineering.

The synergy created between the parts allows the development of a system to successfully manage projects and issues step by step. Over the years Everel has been building a strong corporate philosophy where the attention and the customer value are the main assets. For this reason all customer targets become Everel targets.

Global presence

Everel Group has its headquarters in Italy, with production plants and offices in Germany and Romania. Seven hundred employees contribute to Everel's worldwide success every day.

Web Tools

Web site: www.everelgroup.com

Visit our Web site: you will find all news and details you may need about the Company, its products, certifications and international sales network. Moreover, looking into the catalogue section, you can find every Everel products' data sheet.

You can also get in touch with us directly through the contact section.



Social Network and Applications



Facebook

Pictures, news and much more.

<https://www.facebook.com/everelgroupspa/>



LinkedIn

Follow our updates and job opportunities.

<https://www.linkedin.com/company/everel>



Twitter

Follow the tweets, become a Follower!

<https://twitter.com/EverelGroup>



QR code

Use your Smartphone to surf the mobile version of Everel Web site.

Products & Applications



OVEN

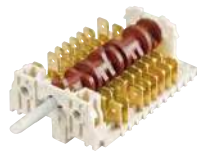

Selectors



Indicator lights



Encoders



Push-button switches



Ventilation units



WASHING MACHINE



Push-button switches



Indicator lights



Encoders



Push-button switches



COFFEE MACHINE



Rocker switches



Indicator lights



Encoders



Power connectors



Push-button switches



HAIRDRYER



Slide switches



Rocker switches



Sub-assemblies



Micro switches



Hairdryer switches



COOKER HOOD

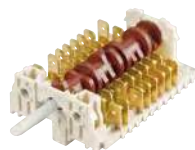

Selectors



Control boards



Indicator lights



Slide switches



Push-button switches



Power connectors



DISHWASHER



Ventilation unit



Encoders



Indicator lights



Push-button switches



VACUUM CLEANER



Rocker switches



Push-button switches



Indicator lights



Waterproof switches



Rotary switches



CLEANING EQUIPMENT



Push-button switches



Rotary switches



Indicator lights



Waterproof switches



Rocker switches



REFRIGERATION



Rocker switches



Indicator lights



Push-button switches



Push-button switches



SMALL APPLIANCES



Micro Switches



Rotary switches



Sub-assemblies



Power connectors



Indicator lights



GARDENING



Rocker switches



Indicator lights



Slide switches



Waterproof switches



Push-button switches



HEATING AND VENTILATION



Motors



Ventilation Units



Brushless motors

Mec-tronic competences

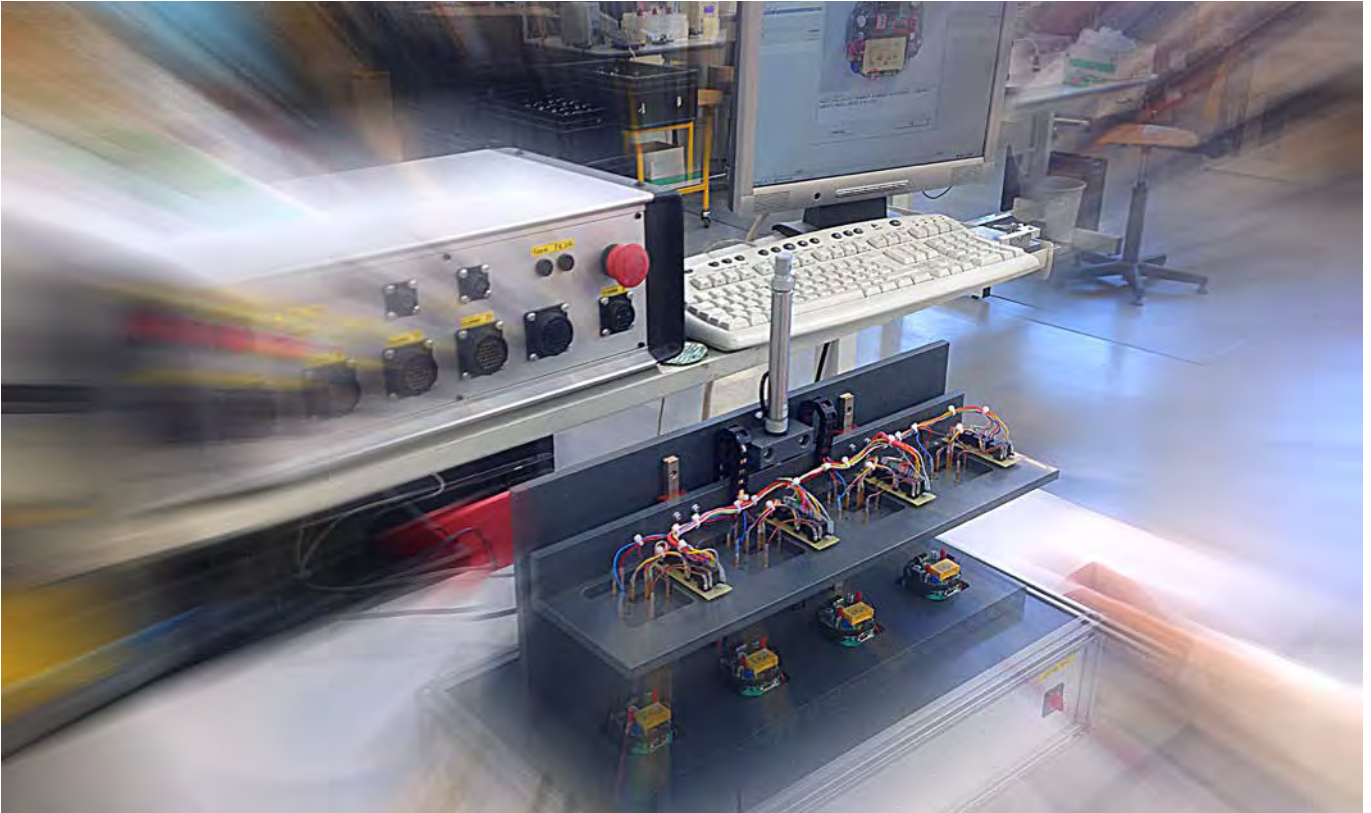

Everel has strong R&D and Innovation departments which combine mechanic and electric/electronic competences. Through a close cooperation with customers, a wide variety of Smart solutions are being designed and produced creating Adding Value and Cost Effectiveness.

Applications

MEC-TRONIC Solutions are available for White Goods (Ovens, Cooker hobs, Refrigerators), as well as for Small appliances (Blenders, Coffee machines), or HVAC (Air treatment, Air Extractors).





ELECTRONIC ILLUMINATED PUSH-BUTTON SWITCH WITH TIMER

Led-illuminated momentary switch with embedded microprocessor circuit board and power supply

An illuminated mechanic push button is attached to a PCB managing the refrigerator's fast freezing.

When the button is pushed, it switches on the super cooling, and automatically disconnecting it after 72 hours of service.

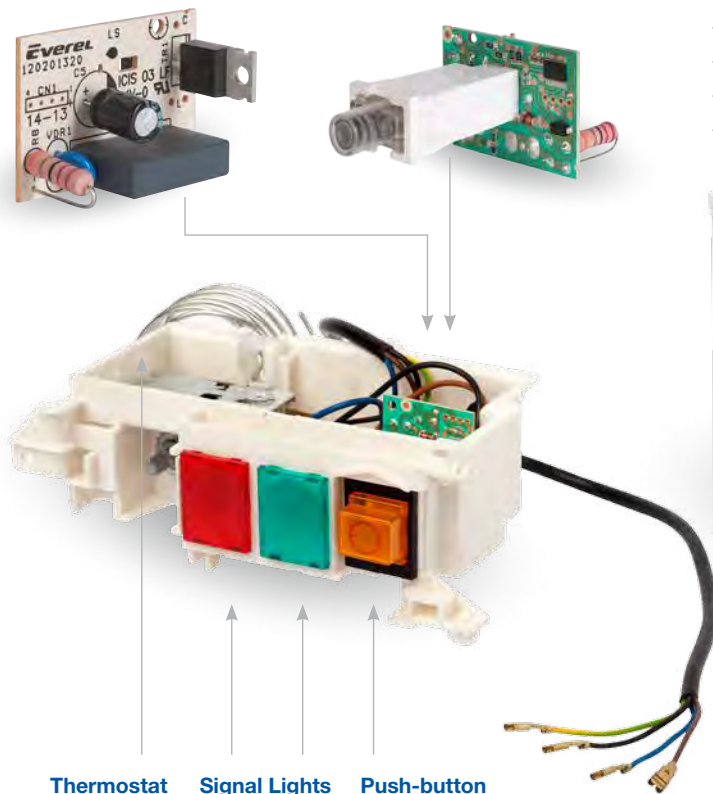

APPLICATION	Low-power switching control for small and large appliances
POWER SUPPLY	220-240 VAC
FREQUENCY	50-60Hz
LOAD TYPE	0,95A, 220-240 VAC
STAND-BY POWER	< 0,15W
TEMPERATURE	T65
SWITCHES	1 TRIAC





COFFEE MACHINE TIMER

This control timer manages the heater and dispenser pump loads of a coffee machine

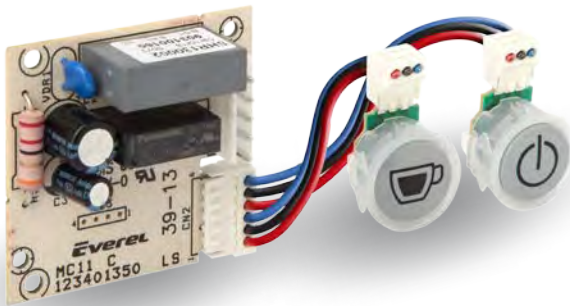

THE HARDWARE

All inputs and outputs necessary to manage the coffee machine are included in this hardware; an integrated system of energy saving switches the machine off after a pre set stand-by time.

Many functions are available:

- counting capsule
- water heater temperature control
- safety function of the warm water delivery
- set up the stand by time

This sub assembly solution is composed by:

- 1 electronic PCB
- 1 software
- 2 electrical push button switches (made of polycarbonate to better spread break forth the ledlight)

The control timer is highly customizable:

- body shape and marking on demand
- cable lengths
- led light colour
- Taylor made software

The system comprises a PCB board, which manages the coffee machine, and two illuminated push buttons, one for main on/off, the other to select the coffee.

Its flexibility and reliability allow a perfect integration in most coffee machines. More customizations are also possible.

APPLICATION	Electronic timer switch for coffee machine
POWER SUPPLY	230 VAC
FREQUENCY	50-60HZ
LOAD TYPE 1	max. 1kw, 230 VAC
LOAD TYPE 2	max. 50W, 230 VAC
STAND-BY POWER	<0,25W
TEMPERATURE	T85
SWITCH 1	Relay
SWITCH 2	Triac





ELECTRONIC TIMER WITH PUSH KNOB

Management of cooking time and delayed baking in Oven Applications

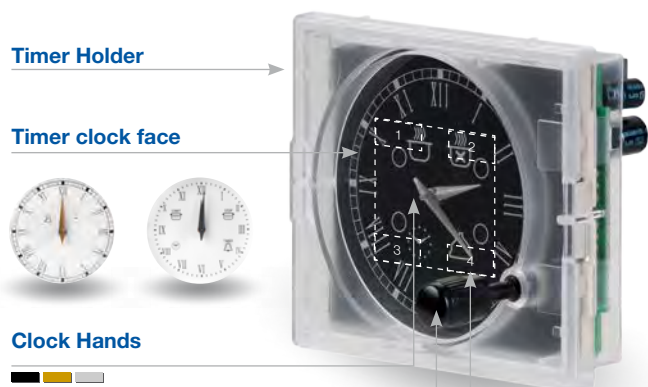

Timer Holder

Timer clock face



Clock Hands



Clock Push-Knob Finishing



LED's & backlighting icons

1. Setup Start of Cooking
2. Setup End of Cooking
3. Setup Minute Minder
4. Setup Clock

This timer governs the time display (with analog hands) and the operation of the oven (using push knob and indicator icons). Pushing on the knob, you can adjust the time, program the start time and end of cooking, set the alarm (Minute Minder).

RATING	220 - 240 VAC (110 - 120 VAC technical contingent)
FREQUENCY	50 - 60Hz
LOAD TYPE	16A, 220 - 240 VAC, $\cos\phi = 1$
CONNECTION	Flat push-on connectors (tab terminals 6.3x0.8mm)
STAND-BY POWER	< 0,5 W (< 0,35 W technical contingent)
TEMPERATURE	T105 (T120 technical contingent)
SWITCHES	1 Relay (2 independent relays technical contingent)
TIMER HOLDER	Lots of typologies to meet any needs (customization technical contingent)
TIMER CLOCK FACE	Lots of typologies to meet any needs (customization technical contingent)
CLOCK HANDS AND KNOB	Many colours available as indicated in the figure

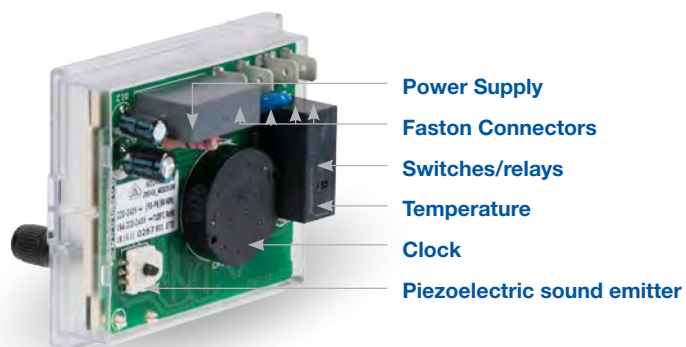

Power Supply

Faston Connectors

Switches/relays

Temperature

Clock

Piezoelectric sound emitter



CONNECTIONS

Power supply tab terminals
Switch tab terminals relay integrated

INPUT/OUTPUT FROM BOARD

No. 1 Piezoelectric sound emitter
No. 1 Led for backlighting icons
No. 3 push knob program management



ELECTRONIC DIGITAL TIMER

This timer/ Timer switch controls the time of the day (with led digit display), minute minder, cooking duration and cooking end time (using 3 touch buttons). The programmer buttons (touch control timer). There are three buttons on this type of timer.



RATING	220 - 240 VAC (110 - 120 VAC technical contingent)
FREQUENCY	50 - 60Hz
LOAD TYPE	16A, 220 - 240 VAC, cosφ = 1
CONNECTION	Flat push-on connectors (tab terminals 6.3x0.8mm)
STAND-BY POWER	< 0,5 W (< 0,35 W technical contingent)
TEMPERATURE	T105 (T120 technical contingent)
SWITCHES	1 Relay (2 independent relays technical contingent)
TIMER HOLDER	Lots of typologies to meet any needs (customization technical contingent)
TIMER CLOCK FACE	Lots of typologies to meet any needs (customization technical contingent)
CLOCK HANDS AND KNOB	Many colours available as indicated in the figure

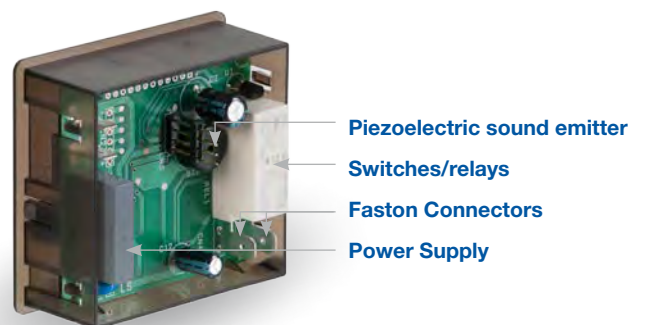

CONNECTIONS

Power supply tab terminals
Switch tab terminals relay integrated

INPUT/OUTPUT FROM BOARD

No. 1 Piezoelectric sound emitter
No. 1 Led display
No. 3 touch sensor program management



SMART ENCODER

Great reliability under critical conditions:
high operating temperatures, vibrations, dust

A wide variety of encoder platforms has been designed, matching customer's needs and giving extra features and high reliability.

- Output parameters: binary BCD, Resistor array, potentiometer, incremental
- Positions: up to 20
- Push to select function
- Possibility for momentary zones with automatic return or free rotations
- Different shaft torques available
- Different noise levels available
- Installation: welding Pins, wirings, terminals
- Integrated LEDs

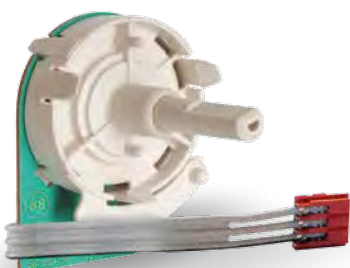

CS1
Fixing Type: Snap-in
H Shaft (mm): 22,5
Number of positions: 16 P



MV2
Fixing Type: Soldering pin
H Shaft (mm): 12,7
Number of positions:
 Free rotation 360° with step



OVEN CONTROL

Advanced integrated mechatronic user interfaces

Everel supplies customized oven control solutions, combining together user-friendly mechanical interfaces and advanced electronic technologies to allow customers to market exclusive easy-to-use appliance controls.

Our dual-rotary solution provides a way to set and control two variables, for example oven function and temperature, with just one knob. Advanced features such as LED lighting and DISPLAY can be embedded in the knob. Also the knob can become a push-button, for example to confirm the selected oven program.

The external knob is then interfaced to the electronic unit, which can be customized by Everel to meet the customer needs and includes power controls, touch capacitive displays and power supply.



Customizable images/text

Index

01



ROCKER SWITCHES

A1	42
TECNO	46
A8	48
GP	50
A2	52
A4	54
B10	58
SX81	60
SX8A	62
SX82	64
SX83	66
SXD1	68

PUSH-BUTTON SWITCHES

SXL4	72
SCA	74
P1	76
SP60	78
SP63	80
SXL5	82
LITE	84
DY1	86
DY2	88
DY Accessories	90
SPM	92
TOUCH	94
RFIT	96

WATERPROOF SWITCHES

SXL44	100
B4MASK	102
SXA4	104
RMASK	106
SXLR	108

HAIRDRYER SWITCHES

CO	112
CN	116
CP	120
CB	122
CK	124
CS	126
DC	128
SUB-ASSEMBLIES	130

SLIDE AND ROTARY SWITCHES

LF	134
P5	136
R1	138
DS	140
DH	141

MICRO SWITCHES

MSA	144
MSS	146

02



CONTROL BOARDS

T5	150
TM4	152
TM5	153

03



INDICATOR LIGHTS SWITCHES SIZE

A5	156
A7	156
B5	158
B6	158
B7	160
SP60 indicator light	160

INDICATOR LIGHTS

SX17	164
SX21	164
SX24	166
SX27	166
SX28	168
SX31	170
SX33	170
SX41	172
SX43	172
Accessories	172

04

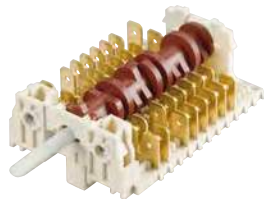

SELECTORS

HE	176
5HE 7TAKT	180
5HE 7TAKT DUO	182
HT	184
5HE 4 BLOCK	186
CH	187
2CH WITH ENCODER	188

CODI

CS	193
CV	194

MINICODI

MS	199
MF	200
MB	200
MV	201
MK	202

05

**MOTORS**

Shaded Pole Motor Ø 52	206
Shaded Pole Motor Ø 58	208
Fans and Accessories	210
EC Brushless Motor	212

VENTILATION UNITS

Ventilation Blower	216
Axial Blower	217
Axial/Tangential Blower	218
Fan Blower 50 mm deep	219
Centrifugal Blower to exhaust cooking vapours	220
Ventilation Unit for Oven	221
Dishwasher Cooling Ventilation Unit	222

06

**POWER CONNECTORS**

STS	226
SFS	226
SST	227
SW	228
STF	230
SFO	231
SCM81	231

Rocker Switches

01



A1

42



SX81

60



TECNO

46



SX8A

62



A8

48



SX82

64



GP

50



SX83

66



A2

52



SXD1

68



A4

54



B10

58



A1

TYPICAL APPLICATIONS Small appliances

FUNCTIONS ■ SPST, momentary or not
■ SPDT, momentary or not

CYCLE No. 50.000

CUT OUT 19x13 mm

AMBIENT TEMPERATURE 125 °C

GWT 850 °C

GWT NO FLAME (<2sec) 750 °C on demand



A 1

DRAWING

?

TERMINAL



A1PRT

WATERPROOF CAP

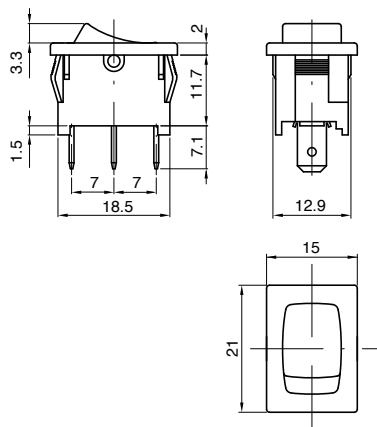

1

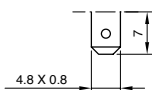

2

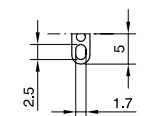

A

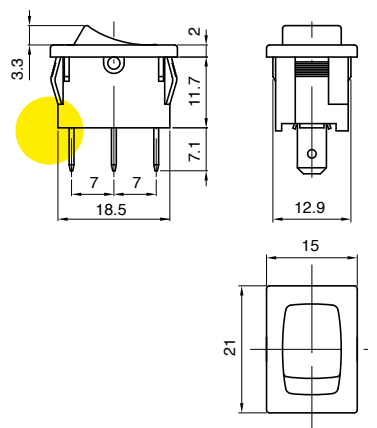
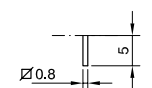

7

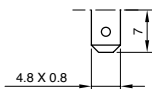

8

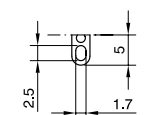

CUSTOMIZABLE

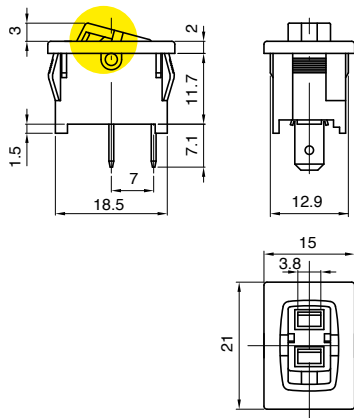

9

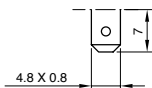

E

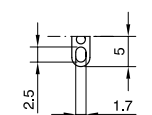

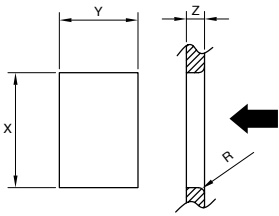

Z	Y	X
0,75 ... 1,25	13,0 ±0,1	19,0 ±0,1
1,25 ... 2,0	13,0 ±0,1	19,3 ±0,2
2,0 ... 3,0	13,0 ±0,1	19,6 ±0,2

TERMINAL	FUNCTION	RATING	BODY COLOUR	ROCKER COLOUR	MARKING COLOUR	MARKING
A	1					0 0 0

?	?	?	?	?	?	0 0 0
---	---	---	---	---	---	-------

FUNCTION RATING BODY COLOUR ROCKER COLOUR MARKING COLOUR MARKING

1

3 Terminal 1 - 2 - 9 - E

4 Terminal 1 - 2 - 7 - 8

A Terminal 1 - 2 - 7 - 8

B Terminal 1 - 2

2

Terminal 1 - 2
Function 4 - A - B

6 (2) A / 250 VAC
3 (1) A / 250 VAC - 5E4
T125/55 °C - T125 °C
EN 61058

6 A - 125 / 250 VAC
1/10 HP - 125 VAC
1/6 HP - 250 VAC
T105 °C
UL 1054
CSA C22.2

3

Terminal 1 - 2 - 7 - 8 - 9 - A - E
Function 1 - 3

10 (4) A / 250 VAC
6 (6) A / 250 VAC
6 (4) A / 250 VAC - 5E4
T125/55 °C - T125 °C
EN 61058

10 A - 125 / 250 VAC
1/3 HP - 125 VAC
1/2 HP - 250 VAC
T105 °C
UL 1054
CSA C22.2

7

Terminal 7 - 8
Function 4 - A

10 (2) A / 250 VAC
6 (1) A / 250 VAC - 5E4
T125/55 °C - T125 °C
EN 61058

10 A - 125 / 250 VAC
1/10 HP - 125 VAC
1/6 HP - 250 VAC
T105 °C
UL 1054
CSA C22.2

B

Terminal 1 - 2 - 9 - E
Function 1 - 3

13 (4) A / 250 VAC
6 (6) A / 250 VAC - 5E4
T125/55 °C - T125 °C
EN 61058

15 A / 125 VAC
10 A / 250 VAC
1/3 HP - 125 VAC
1/2 HP - 250 VAC
T105 °C
UL 1054
CSA C22.2

1 black

2 white

9 red

X custom

1 black

2 white

9 red

X custom

0 none

1 black

2 white

5 grey

7 light blue

8 red

9 orange

X custom

0

1

2

3

4

5

6

8

C

F

G

Z

R

X



A1

TYPICAL APPLICATIONS Small appliances

- FUNCTIONS**
- SPST, illuminated or not
 - SPDT
 - SPCO

CYCLE No. 50.000

CUT OUT 19x13 mm

AMBIENT TEMPERATURE 125 °C

GWT 850 °C

GWT NO FLAME (<2sec) 750 °C on demand



A 1

DRAWING

?

TERMINAL



A1PRT

WATERPROOF CAP

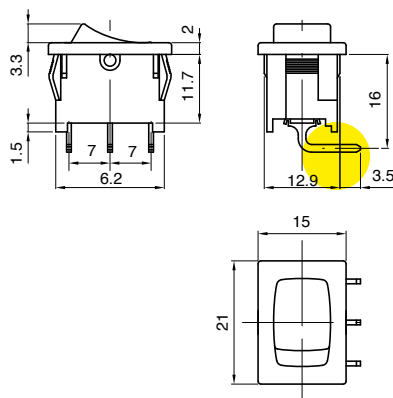

C

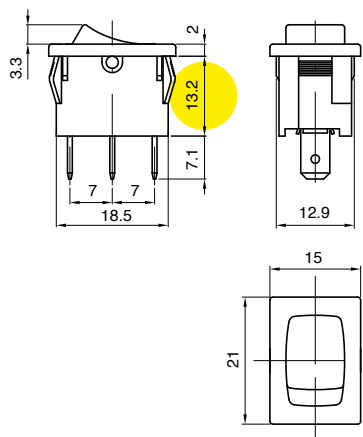
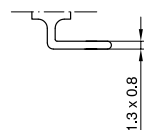

1

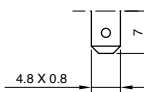

2

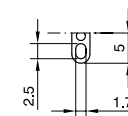

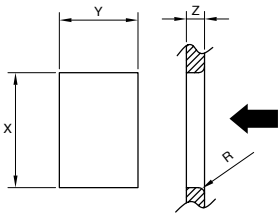

Z	Y	X
0,75 ... 1,25	13,0 ±0,1	19,0 ±0,1
1,25 ... 2,0	13,0 ±0,1	19,3 ±0,2
2,0 ... 3,0	13,0 ±0,1	19,6 ±0,2

TERMINAL	FUNCTION	RATING	BODY COLOUR	ROCKER COLOUR	MARKING COLOUR	MARKING
A	1					0 0 0

?	?	?	?	?	?	0 0 0
---	---	---	---	---	---	-------

FUNCTION RATING BODY COLOUR ROCKER COLOUR MARKING COLOUR MARKING

1 Terminal C



3 Terminal C



5 Terminal 1 - 2



6 Terminal 1 - 2



3

Terminal 1 - 2 - C
Function 1 - 3 - 6
10 (4) A / 250 VAC
6 (6) A / 250 VAC
6 (4) A / 250 VAC - 5E4
T125/55 °C - T125 °C
EN 61058

10 A - 125 / 250 VAC
 1/3 HP - 125 VAC
 1/2 HP - 250 VAC
 T105 °C
 UL 1054
 CSA C22.2

6

Terminal 1 - 2
Function 5
10 (2) A / 250 VAC
6 (1) A / 250 VAC - 5E4
T125/55 °C - T125 °C
µ disconnection
EN 61058

6 A - 125 / 250 VAC
 1/8 HP - 125 VAC
 1/6 HP - 250 VAC
 T105 °C
 UL 1054
 CSA C22.2

B

Terminal 1
Function 6
13 (4) A / 250 VAC
6 (6) A / 250 VAC - 5E4
T125/55 °C - T125 °C
EN 61058

15 A / 125 VAC
 10 A / 250 VAC
 1/3 HP - 125 VAC
 1/2 HP - 250 VAC
 T105 °C
 UL 1054
 CSA C22.2

Terminal 1 - 2
Function 5
13 (4) A / 250 VAC
6 (6) A / 250 VAC - 5E4
T125/55 °C - T125 °C
µ disconnection
EN 61058

15 A / 125 VAC
 10 A / 250 VAC
 1/3 HP - 125 VAC
 1/2 HP - 250 VAC
 T105 °C
 UL 1054
 CSA C22.2

1 black

2 white

9 red

X custom

1 black

2 white

9 red

ILLUMINATED

G red

H orange

E green

L white

X custom

0 none

1 black

2 white

5 grey

7 light blue

8 red

9 orange

X custom

0

1

2

3

4

5

6

8

9

C

F

G

Z

S

R

X



TECNO

TYPICAL APPLICATIONS Cleaning and outdoor, small appliances, chainsaw, gardening

FUNCTIONS ■ SPST, momentary or not

CYCLE No. 50.000

CUT OUT 19x13 mm

AMBIENT TEMPERATURE 125 °C

GWT 850 °C

GWT NO FLAME (<2sec) 750 °C on demand



T E C N O ?

DRAWING

7

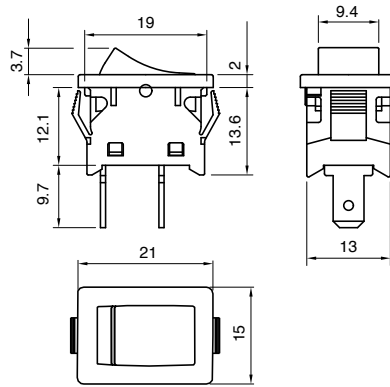

1

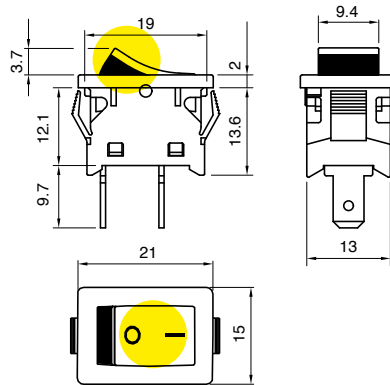

?

TERMINAL

1

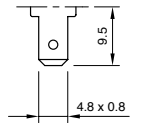

2

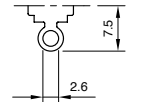

NOTES

Water splash proof body

T E C N O 4

DRAWING

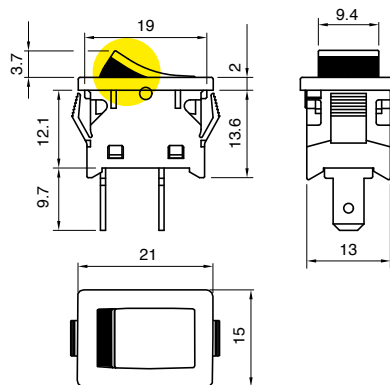

?

TERMINAL

1

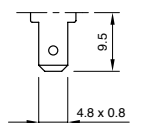

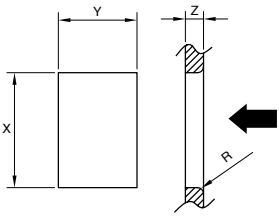

Z	Y	X
0,75 ... 3,5	13,0	+0,2 0
		19,0
		+0,2 0

T	E	C	N	O	DRAWING	TERMINAL	FUNCTION	RATING	BODY COLOUR	ROCKER COLOUR	MARKING COLOUR	MARKING	0	0	0

?	?	?	?	?	?	?	0	0	0
---	---	---	---	---	---	---	---	---	---

FUNCTION RATING BODY COLOR ROCKER COLOUR MARKING COLOUR MARKING

<p>1</p> <p>4 Drawing 7</p> <p>A Drawing 7</p>	<p>3</p> <p>10 (4) A / 250 VAC 10 / 100 A / 250 VAC 6 (4) A / 250 VAC - 5E4 T125/55 °C EN 61058</p> <p>15 A / 125 VAC T65 °C UL 1054</p>	<p>1 </p> <p>black</p> <p>X </p> <p>custom</p>	<p>1 </p> <p>black</p> <p>X </p> <p>custom</p>	<p>Drawing 7</p> <p>0</p> <p>none</p> <p>1 </p> <p>black</p> <p>2 </p> <p>white</p> <p>X </p> <p>custom</p> <p>Drawing 1 Side and marking</p> <p>9 </p> <p>red</p>	<p>0 </p> <p>1 </p> <p>3 </p> <p>X </p> <p>Drawing 1 from mould</p> <p>1 </p>
---	---	--	--	---	--

T	E	C	N	O	4	TERMINAL	FUNCTION	RATING	BODY COLOUR	ROCKER COLOUR	MARKING COLOUR	MARKING	0	0

?	?	?	?	?	?	?	0	0
---	---	---	---	---	---	---	---	---

FUNCTION RATING BODY COLOR ROCKER COLOUR MARKING COLOUR MARKING

<p>1</p>	<p>3</p> <p>10 (4) A / 250 VAC 10 / 100 A / 250 VAC 6 (4) A / 250 VAC - 5E4 T125/55 °C EN 61058</p> <p>15 A / 125 VAC T65 °C UL 1054</p>	<p>1 </p> <p>black</p> <p>X </p> <p>custom</p>	<p>19 </p> <p>Top Side black red</p> <p>XX </p> <p>custom</p>	<p>0</p> <p>none</p> <p>2</p> <p>white</p> <p>X </p> <p>custom</p>	<p>0 </p> <p>1 </p> <p>3 </p> <p>X </p>
-----------------	---	--	---	---	---



A8

TYPICAL APPLICATIONS	Small appliances
FUNCTIONS	■ DPST, illuminated or not
CYCLE No.	50.000
CUT OUT	19x13 mm
AMBIENT TEMPERATURE	125°
GWT	850 °C
GWT NO FLAME (<2sec)	750 °C on demand



A 8

DRAWING

?

TERMINAL

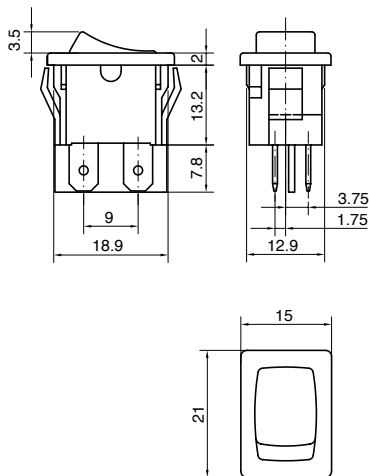

1

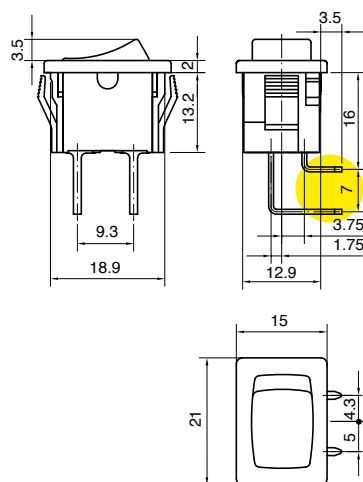
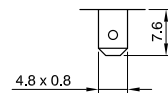

C

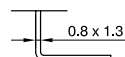

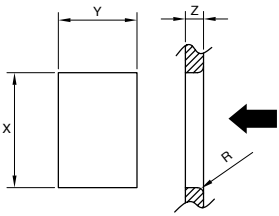

Z	Y	X
0,7 ... 1,25	13,0 ±0,1	19,0 ±0,2
1,25 ... 2,0	13,0 ±0,1	19,3 ±0,2
2,0 ... 3,0	13,0 ±0,1	19,6 ±0,2

DRAWING TERMINAL	FUNCTION	RATING	BODY COLOUR	ROCKER COLOUR	MARKING COLOUR	MARKING
A	8					
						0 0 0

?	?	?	?	?	?	?	0	0	0
FUNCTION	RATING	BODY COLOUR	ROCKER COLOUR	MARKING COLOUR	MARKING				

2

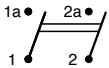

8

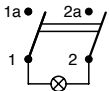

3

10 (4) A / 250 VAC
6 (4) A / 250 VAC - 5E4
T125 °C
EN 61058

10 A - 125 / 250 VAC
1/3 HP - 125 VAC
1/2 HP - 250 VAC
T65 °C
UL 1054
CSA C22.2

1

black

2

white

X

custom

1

black

2

white

8

green

ILLUMINATED

G

red

H

orange

E

green

L

white

X

custom

0

none

1

black

2

white

5

grey

7

light blue

8

red

9

orange

X

custom

0



1



4



6



R



X





GP

TYPICAL APPLICATIONS	Vacuum and steam cleaners
FUNCTIONS	■ DPST, illuminated or not
CYCLE No.	50.000
CUT OUT	19x13 mm
AMBIENT TEMPERATURE	125 °C
GWT	850 °C
GWT NO FLAME (<2sec)	750 °C on demand



G P

DRAWING

?

TERMINAL



WATERPROOF CAP

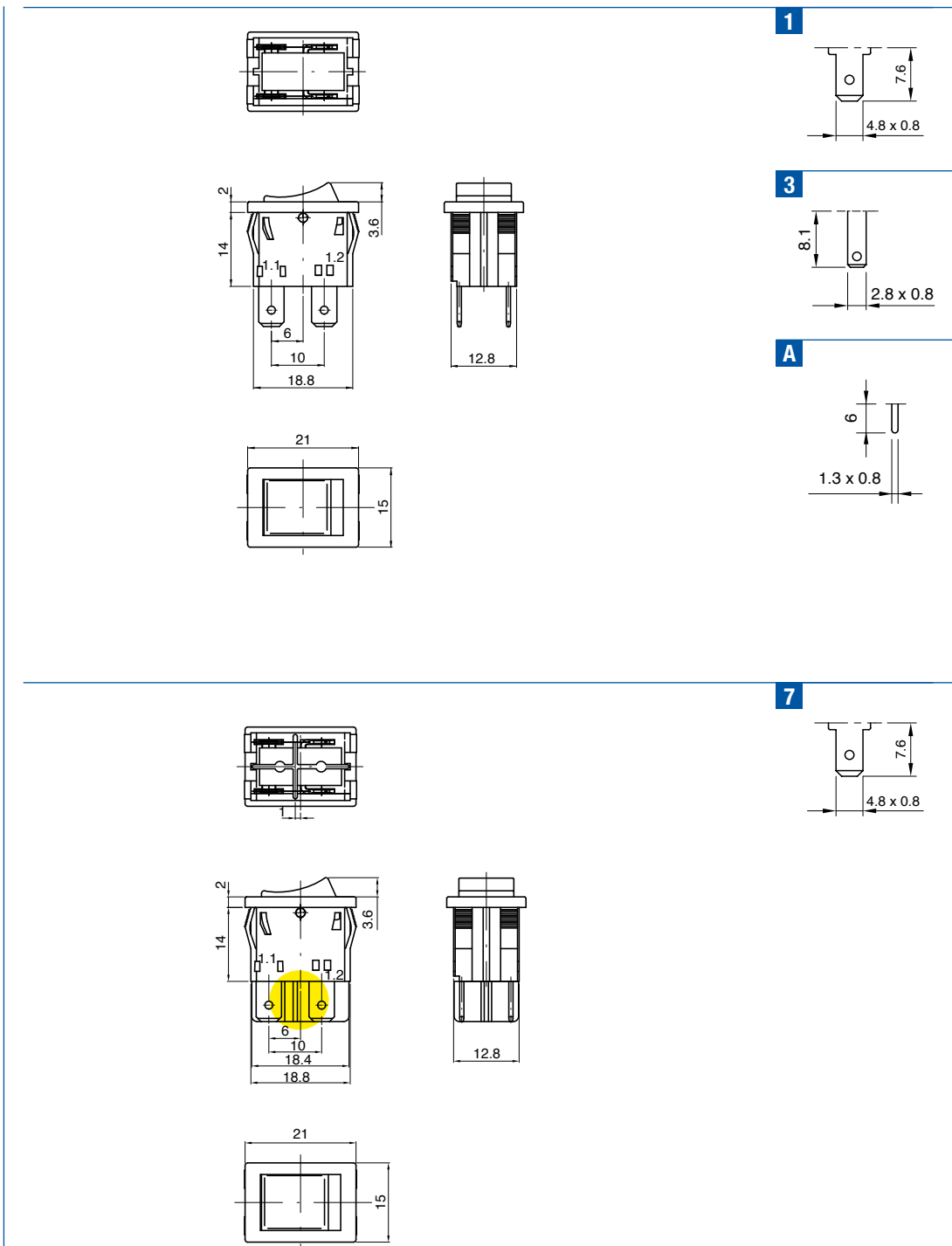

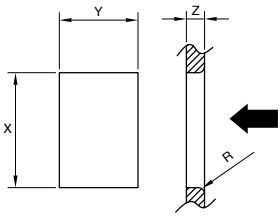

Z	Y	X
0,70 ... 1,25	13,0 ±0,1	19,1 ±0,1
1,25 ... 2,0	13,0 ±0,1	19,4 ±0,1
2,0 ... 3,0	13,0 ±0,1	19,7 ±0,1

TERMINAL	FUNCTION	RATING	BODY COLOUR	ROCKER COLOUR	MARKING COLOUR	MARKING
G	P					
						M 0 0

?	?	?	?	?	?	M 0 0
---	---	---	---	---	---	-------

FUNCTION RATING BODY COLOUR ROCKER COLOUR MARKING COLOUR MARKING

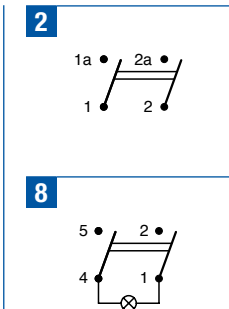

H
 12 A / 250 VAC
 6 (6) A / 250 VAC
 2 / 120 A - 250 VAC
 5 (5) A / 250 VAC - 5E4
 T125/55 °C
 EN 61058

15 A / 125 VAC
 12 A / 250 VAC
 T65 °C
 UL 1054

1
 6 (6) A / 250 VAC
 T125 °C
 EN 61058

- 1** black
- 2** white
- X** custom

- 1** black
- 2** white
- 9** red

ILLUMINATED

- G** red
- E** green
- X** custom

- 0** none
- 1** black
- 2** white
- 8** red
- X** custom

- 0**
- 1**
- 4**
- 6**
- R**
- X**



A2

TYPICAL APPLICATIONS	Hairdryers, small appliances
FUNCTIONS	<ul style="list-style-type: none"> ■ Double SPST ■ Double SPDT momentary ■ SPST, illuminated or not + Indicator light ■ SPST + SPCO
CYCLE No.	50.000
CUT OUT	19x22 mm
AMBIENT TEMPERATURE	125 °C
GWT	850 °C
GWT NO FLAME (<2sec)	750 °C on demand



A 2

DRAWING

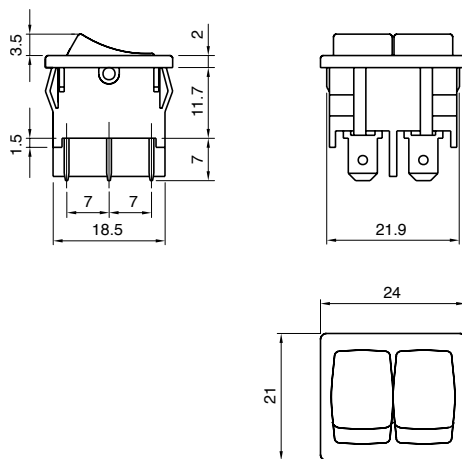

Function K - W

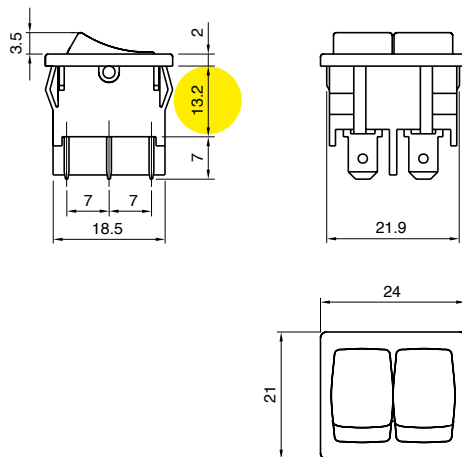

?

TERMINAL

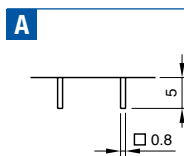
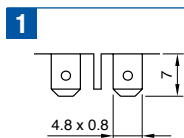

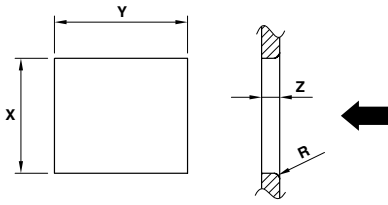

Z	Y	X
0,7 ... 1,25	22,0 ±0,1	19,0 ±0,2
1,25 ... 2,0	22,0 ±0,1	19,3 ±0,2
2,0 ... 3,0	22,0 ±0,1	19,6 ±0,2

TERMINAL	FUNCTION	RATING	BODY COLOUR	ROCKER COLOUR L	ROCKER COLOUR R	MARKING COLOUR	MARKING L	MARKING R
A	2							

FUNCTION	RATING	BODY COLOUR	ROCKER COLOUR	MARKING COLOUR	MARKING
?	?	?	L ? R ?	?	L ? R ?

0	0
---	---

1 Terminal 1

B Terminal 1

G Terminal 1

K Terminal A

W Terminal 1

2

Function B
6 (2) A / 250 VAC
3 (1) A / 250 VAC - 5E4
T125/55 °C - T125 °C
EN 61058

6 A - 125 / 250 VAC
 1/10 HP - 125 VAC
 1/6 HP - 250 VAC
 T105 °C
 UL 1054
 CSA C22.2

3

Function 1 - G - W
10 (4) A / 250 VAC
6 (4) A / 250 VAC - 5E4
T125/55 °C - T125 °C
EN 61058

10 A - 125 / 250 VAC
 1/3 HP - 125 VAC
 1/2 HP - 250 VAC
 T105 °C
 UL 1054
 CSA C22.2

6

Function K
10 (2) A / 250 VAC
6 (1) A / 250 VAC - 5E4
T125/55 °C - T125 °C
µ disconnection
EN 61058

6 A - 125 / 250 VAC
 1/8 HP - 125 VAC
 1/6 HP - 250 VAC
 T105 °C
 UL 1054
 CSA C22.2

1 black

2 white

X custom

L **R**

1 black

2 white

9 red

B light blue

ILLUMINATED

G red

H orange

E green

L white

X custom

0 none

1 black

2 white

5 grey

7 light blue

8 red

9 orange

X custom

0

1

2

3

4

5

6

8

9

C

F

G

S

R

Z

X



A4

TYPICAL APPLICATIONS Vacuum cleaners, HVAC

- FUNCTIONS**
- SPST, momentary or not
 - DPST, illuminated or not
 - DPCO
 - DPDT, momentary or not

CYCLE No. 50.000

CUT OUT 19x22 mm

AMBIENT TEMPERATURE 125 °C

GWT 850 °C

GWT NO FLAME (<2sec) 750 °C on demand



A

4

DRAWING



WATERPROOF CAP

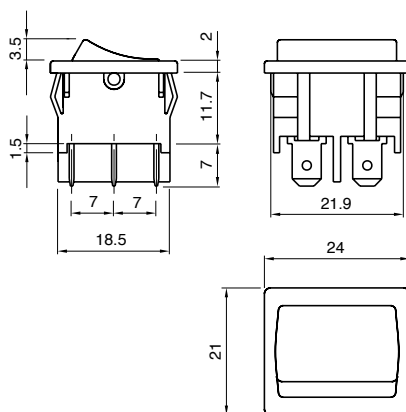

?

TERMINAL

1

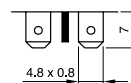

2

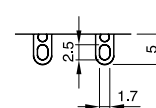

Function 9

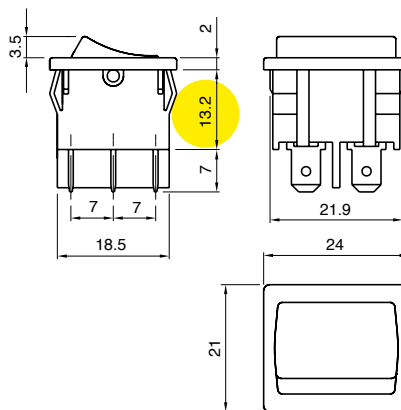

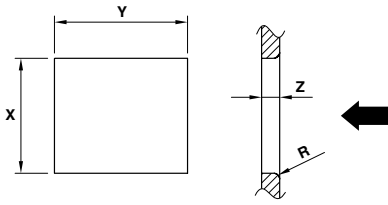

Z	Y	X
0,7 ... 1,25	22,0 ±0,1	19,0 ±0,2
1,25 ... 2,0	22,0 ±0,1	19,3 ±0,2
2,0 ... 3,0	22,0 ±0,1	19,6 ±0,2

TERMINAL	FUNCTION	RATING	BODY COLOUR	ROCKER COLOUR	MARKING COLOUR	MARKING
A	4					0 0 0

?	?	?	?	?	?	0	0	0
---	---	---	---	---	---	---	---	---

FUNCTION RATING BODY COLOUR ROCKER COLOUR MARKING COLOUR MARKING

1

2

4

8

9

L

M

2

Function 4 - M
6 (2) A / 250 VAC
3 (1) A / 250 VAC - 5E4
T125/55 °C - T125 °C
EN 61058

6 A - 125 / 250 VAC
 1/6 HP - 250 VAC
 1/10 HP - 125 VAC
 T105 °C
 UL 1054
 CSA C22.2

3

Function 1 - 2 - L - 8
10 (4) A / 250 VAC
6 (4) A / 250 VAC - 5E4
T125/55 °C - T125 °C
EN 61058

10 A - 125 / 250 VAC
 1/3 HP - 125 VAC
 1/2 HP - 250 VAC
 T105 °C
 UL 1054
 CSA C22.2

6

Function 9
10 (2) A / 250 VAC
6 (1) A / 250 VAC - 5E4
T125/55 °C - T125 °C
µ disconnection
EN 61058

6 A - 125 / 250 VAC
 1/8 HP - 125 VAC
 1/6 HP - 250 VAC
 T105 °C
 UL 1054
 CSA C22.2

B

Function 2
13 (4) A / 250 VAC
8 (8) A / 250 VAC - 5E4
T125/55 °C - T125 °C
EN 61058

15 A / 125 VAC
 10 A / 250 VAC
 1/3 HP - 125 VAC
 1/2 HP - 250 VAC
 T105 °C
 UL 1054
 CSA C22.2

Function 9
13 (4) A / 250 VAC
6 (4) A / 250 VAC - 5E4
T125/55 °C - T125 °C
µ disconnection
EN 61058

15 A / 125 VAC
 10 A / 250 VAC
 1/3 HP - 125 VAC
 1/2 HP - 250 VAC
 T105 °C
 UL 1054
 CSA C22.2

1 black

2 white

X custom

1 black

2 white

ILLUMINATED

G red

H orange

E green

L white

X custom

0 none

1 black

2 white

5 grey

7 light blue

8 red

9 orange

X custom

0

1

2

3

5

9

C

K

N

Z

X



A4

TYPICAL APPLICATIONS	Vacuum cleaners, HVAC
FUNCTIONS	<ul style="list-style-type: none"> ■ DPST, illuminated or not ■ DPDT
CYCLE No.	50.000
CUT OUT	19x22 mm
AMBIENT TEMPERATURE	125 °C
GWT	850 °C
GWT NO FLAME (<2sec)	750 °C on demand



A 4

DRAWING

?

TERMINAL



WATERPROOF CAP

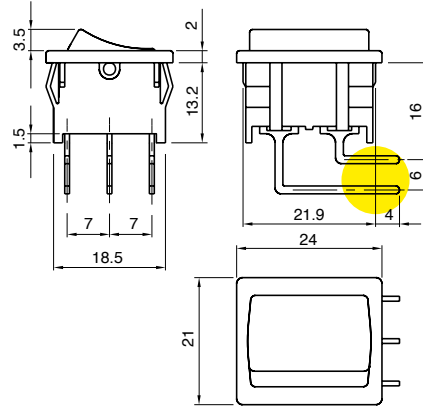

C

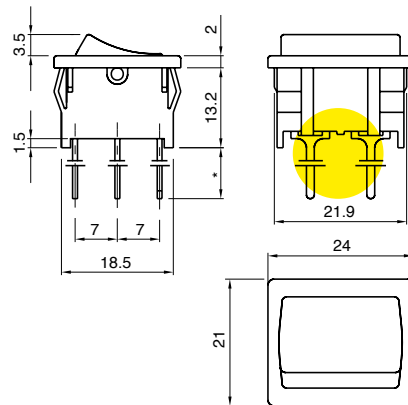
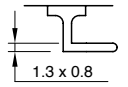

5

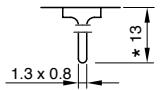

6

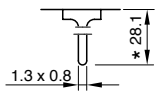

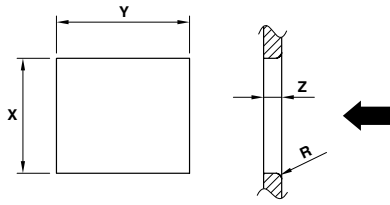

Z	Y	X
0,7 ... 1,25	22,0 ±0,1	19,0 ±0,2
1,25 ... 2,0	22,0 ±0,1	19,3 ±0,2
2,0 ... 3,0	22,0 ±0,1	19,6 ±0,2

TERMINAL	FUNCTION	RATING	BODY COLOUR	ROCKER COLOUR	MARKING COLOUR	MARKING
A	4					0 0 0

?	?	?	?	?	?	0	0	0
FUNCTION	RATING	BODY COLOUR	ROCKER COLOUR	MARKING COLOUR	MARKING			

2 Terminal C - 6

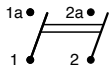

8 Terminal C

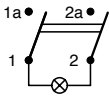

L Terminal 5

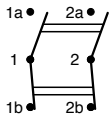

3

10 (4) A / 250 VAC
 6 (4) A / 250 VAC - 5E4
 T125/55 °C - T125 °C
 EN 61058

10 A - 125 / 250 VAC
 1/3 HP - 125 VAC
 1/2 HP - 250 VAC
 T105 °C
 UL 1054
 CSA C22.2

1 black

2 white

X custom

1 black

2 white

ILLUMINATED

G red

H orange

E green

L white

X custom

0 none

1 black

2 white

5 grey

7 light blue

8 red

9 orange

X custom

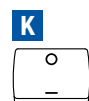
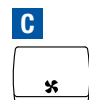
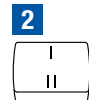
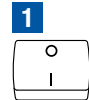



B10

TYPICAL APPLICATIONS Ironing systems

- FUNCTIONS**
- SPST, momentary or not
 - SPDT, momentary or not
 - SPCO

CYCLE No. 50.000

CUT OUT 27x12 mm

AMBIENT TEMPERATURE 120 °C

GWT 850 °C

GWT NO FLAME (<2sec) 750 °C on demand



B 1 0

?

DRAWING

TERMINAL

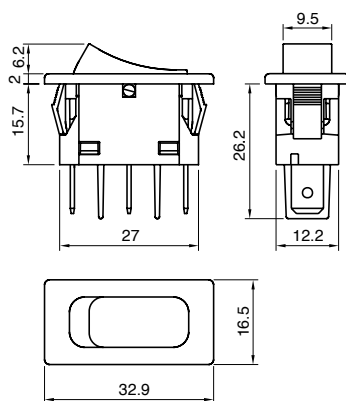

1

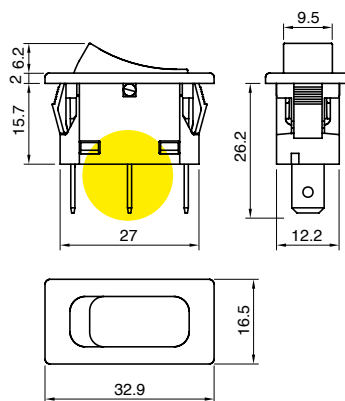
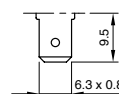

6

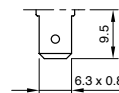

T

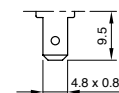

U

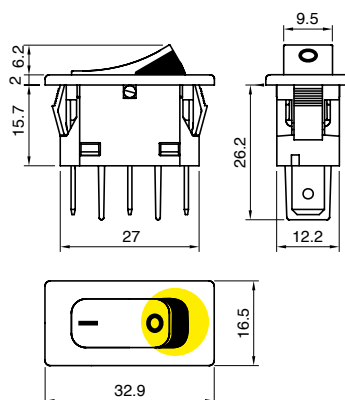
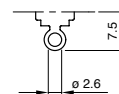

3

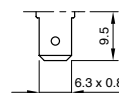

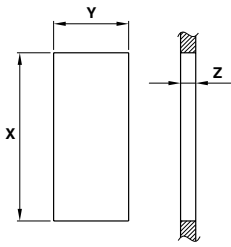

Z	Y	X
0,75 ... 1,25	12,4	$\begin{matrix} +0,2 \\ 0 \end{matrix}$ 27,4
1,25 ... 2,0	12,4	$\begin{matrix} +0,2 \\ 0 \end{matrix}$ 27,6
2,0 ... 3,0	12,4	$\begin{matrix} +0,2 \\ 0 \end{matrix}$ 27,8

TERMINAL	FUNCTION	RATING	BODY COLOUR	ROCKER COLOUR	MARKING COLOUR	MARKING
B	1	0				
						0 0 0

?	?	?	?	?	?	?	0	0	0
---	---	---	---	---	---	---	---	---	---

FUNCTION RATING BODY COLOUR ROCKER COLOUR MARKING COLOUR MARKING

1

3 Terminal 1 - 6 - U

4 Terminal 1 - 6 - U

5 Terminal 1 - 6 - U

A Terminal 1 - 6 - U

B Terminal 1 - 6 - U

1

Function 1
4 (1) A / 250 VAC
2 (0.5) A / 250 VAC - 5E4
T120/55 °C
EN 61058

C

Terminal 1 - 6 - U - 3
16 (6) A / 250 VAC
10 (4) A / 250 VAC - 5E4
T120/55 °C
EN 61058

20 A / 125 VAC
 16 A / 250 VAC
 1/3 HP - 125 VAC
 3/4 HP - 250 VAC
 T105 °C
 UL 1054
 CSA C22.2

1 black

2 white

X ? custom

1 black

2 white

9 red

X ? custom

0 none

1 black

2 white

5 grey

7 light blue

8 red

9 orange

X ? custom

0

1

2

9

A

N

X ?

Terminal 3 side and marking

8 green

Terminal 3 from mould

1



SX81

TYPICAL APPLICATIONS Refrigerators, electromedical appliances
coffee machines, gardening equipments

FUNCTIONS

- SPST, momentary or not
- SPST illuminated
- SPDT
- SPCO

CYCLE No. 50.000

CUT OUT 30x11 mm

AMBIENT TEMPERATURE 125 °C

GWT 850 °C

GWT NO FLAME (<2sec) 750 °C on demand



S X 8 1 ?

DRAWING

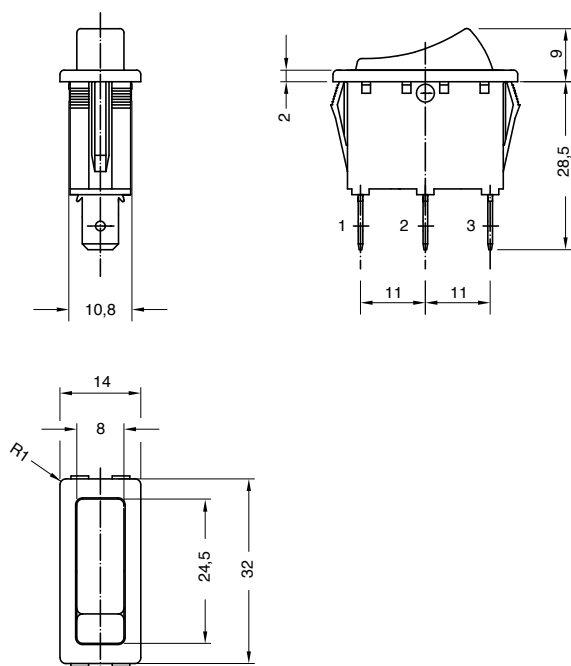

?

TERMINAL

1

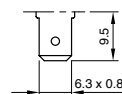

2

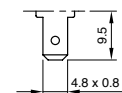

3

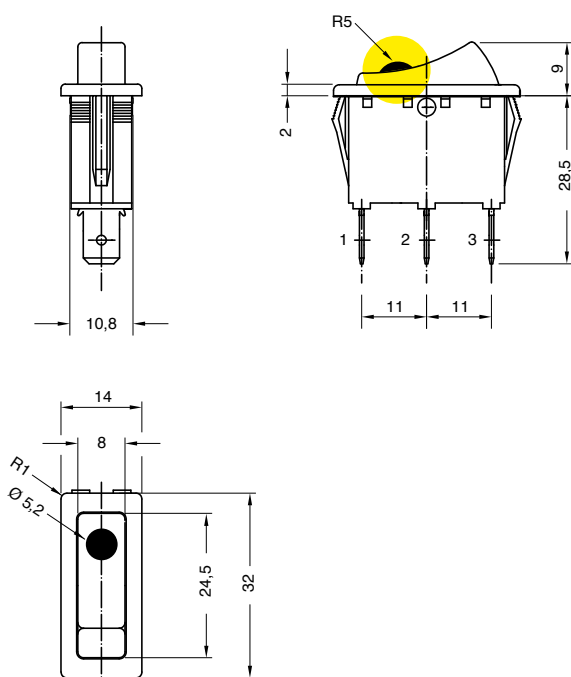

WATERPROOF CAP

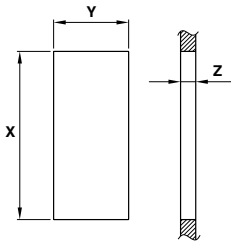

	Z	Y	X
PLASTIC	0,7 ... 3,5	11,0 ±0,1	30,0 +0,2 0
METAL	0,7 ... 2,5	11,0 ±0,1	30,2 +0,2 0

S	X	8	1								0	0	0
---	---	---	---	--	--	--	--	--	--	--	---	---	---

?	?	?	?	?	?	?	?	?	?	?	?	?	?
FUNCTION	RATING	BODY COLOUR	ROCKER COLOUR	MARKING COLOUR	MARKING	LENS COLOUR							

?	0	0	0
?	0	0	0
LENS COLOUR			

1

3

4

5

6

8

Function 1
 20 (2) A / 250 VAC *
 16 (8) A / 250 VAC
 10 (4) A / 400 VAC
 10 (6) A / 250 VAC - 5E4
 T125/55 °C
 EN 61058

20 A / 125 VAC
 16 A / 250 VAC
 3/4 HP - 125 / 250 VAC
 T105 °C
 UL 1054

Function 3 - 4 - B
 16 (6) A / 250 VAC
 10 (4) A / 400 VAC
 10 (4) A / 250 VAC - 5E4
 T125/55 °C
 EN 61058

20 A / 125 VAC
 16 A / 250 VAC
 3/4 HP - 125 / 250 VAC
 T105 °C
 UL 1054

Function 5
 16 (6) A / 250 VAC
 10 (4) A / 250 VAC - 5E4
 T125/55 °C
 EN 61058

16 A - 125 / 250 VAC
 3/4 HP - 125 / 250 VAC
 T105 °C
 UL 1054

Function 6
 20 (2) A / 250 VAC *
 16 (8) A / 250 VAC
 10 (6) A / 250 VAC - 5E4
 T125/55 °C
 EN 61058

20 A / 125 VAC
 16 A / 250 VAC
 3/4 HP - 125 / 250 VAC
 T105 °C
 UL 1054

* Not available with terminal 2

1 black

2 white

X custom

1 black

2 white

9 red

ILLUMINATED

G red

H orange

E green

X custom

0 none

1 black

2 white

X custom

0

1

2

6

A

C

N

X

0 none

ILLUMINATED

G red

H orange

E green

X custom



SX8A

TYPICAL APPLICATIONS	Small appliances
FUNCTIONS	■ SPST, illuminated or not
CYCLE No.	50.000
CUT OUT	28,2x14 mm
AMBIENT TEMPERATURE	125 °C
GWT	850 °C
GWT NO FLAME (<2sec)	750 °C on demand



S X 8 A ?

?

DRAWING

TERMINAL

1

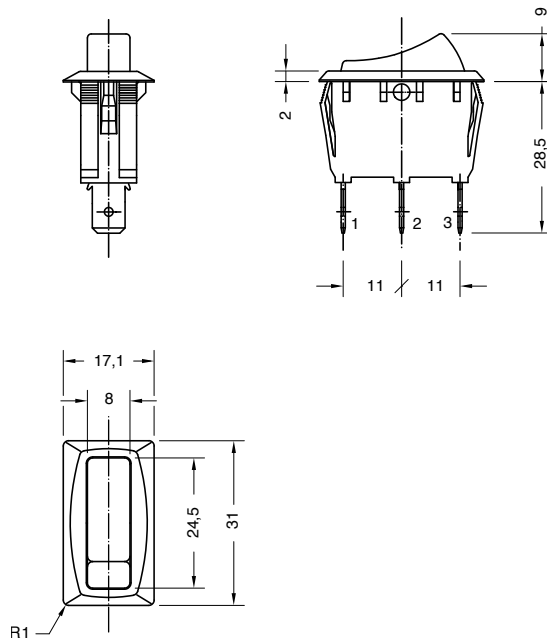

1

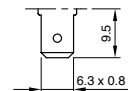

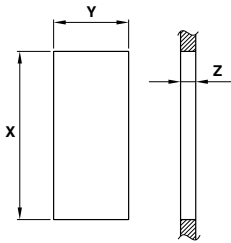

US cut out

Z	Y	X
0,7	14,0 ±0,1	28,2 ±0,1

S	X	8	A	DRAWING	TERMINAL	FUNCTION	RATING	BODY COLOUR	ROCKER COLOUR	MARKING COLOUR	MARKING	0	0	0	0

?	?	?	?	?	?	0	0	0	0
FUNCTION	RATING	BODY COLOUR	ROCKER COLOUR	MARKING COLOUR	MARKING				

0	0	0	0
---	---	---	---

1

6

?

Other function available on demand

8

Function 1

20 (2) A / 250 VAC
 16 (8) A / 250 VAC
 10 (6) A / 250 VAC - 5E4
 10 (4) A / 400 VAC
 T125/55 °C
 EN 61058

20 A / 125 VAC
 3/4 HP - 125 VAC
 16 A / 250 VAC
 3/4 HP - 250 VAC
 T105 °C
 UL 1054

Function 6

20 (2) A / 250 VAC
 16 (8) A / 250 VAC
 10 (6) A / 250 VAC - 5E4
 T125/55 °C
 EN 61058

20 A / 125 VAC
 3/4 HP - 125 VAC
 16 A / 250 VAC
 3/4 HP - 250 VAC
 T105 °C
 UL 1054

B

Function 6

20 (2) A / 250 VAC
 16 (8) A / 250 VAC
 10 (6) A / 250 VAC - 5E4
 T125/55 °C
 EN 61058

16 A / 250 VAC
 3/4 HP - 250 VAC
 T105 °C
 UL 1054

1 black

2 white

X **?** custom

1 black

2 white

9 red

ILLUMINATED

G red

H orange

E green

X **?** custom

0 none

1 black

2 white

X **?** custom

0

1

2

6

C

N

X **?**



SX82



TYPICAL APPLICATIONS

Coffee machines, refrigerators, ironing steam generators, medical appliances, vacuum cleaners, power inlet

FUNCTIONS

- SPST, illuminated or not
- DPST, momentary or not
- DPST, illuminated or not
- DPCO
- DPDT

CYCLE No.

50.000

CUT OUT

30x22 mm

AMBIENT TEMPERATURE

125 °C

GWT

850 °C

GWT NO FLAME (<2sec)

750 °C on demand

S X 8 2 ?

DRAWING

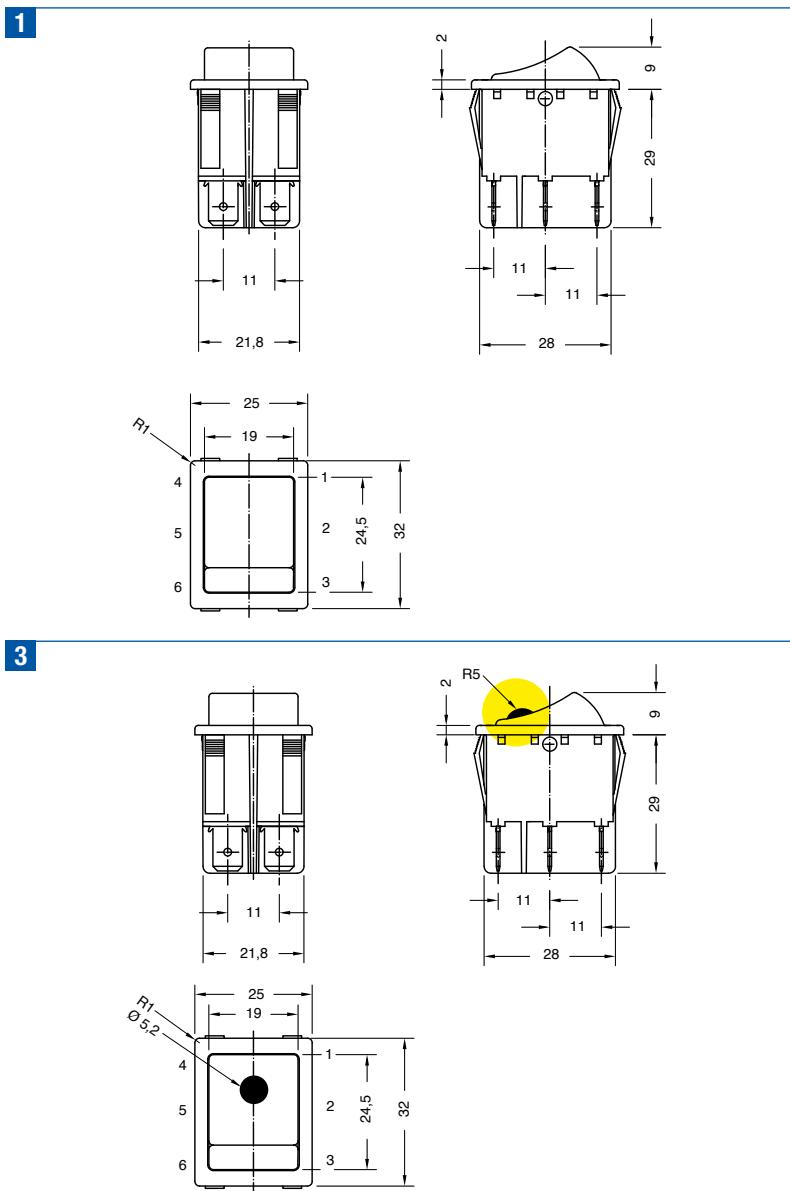

?

TERMINAL

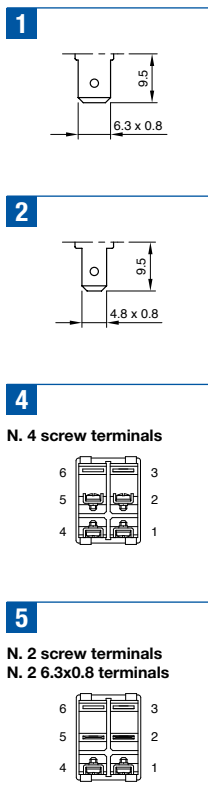

WATERPROOF CAP

P (1 + waterproof cap mounted)

Q (3 + waterproof cap mounted)

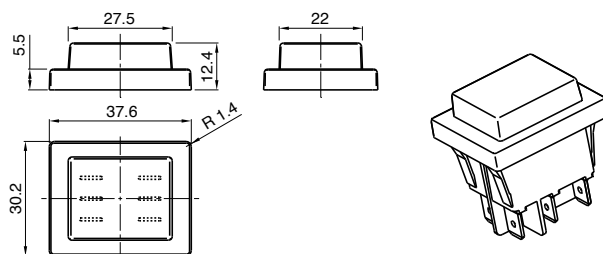

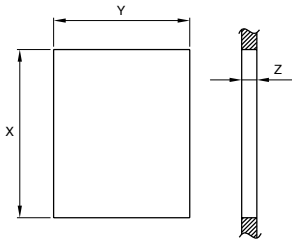

		Z	Y	X
STANDARD	PLASTIC	0,7 ... 3,5	22 ±0,1	30 +0,2 0
WATERPROOF CAP VERSION	METAL	0,7 ... 2,5	22 ±0,1	30,2 +0,2 0

DRAWING	TERMINAL	FUNCTION	RATING	BODY COLOUR	ROCKER COLOUR	MARKING COLOUR	MARKING	LENS COLOUR			
S	X	8	2						0	0	0

?	?	?	?	?	?	?
FUNCTION	RATING	BODY COLOUR	ROCKER COLOUR	MARKING COLOUR	MARKING	LENS COLOUR

?	0	0	0
?	0	0	0

1 Terminal 1 - 2



2

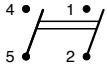

7 Terminal 1

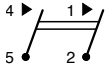

8

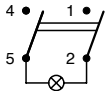

9 Terminal 1

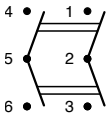

L Terminal 1

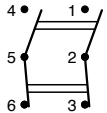

W Terminal 1

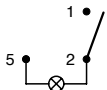

8

Function 1 - 2
 20 (2) A / 250 VAC *
 16 (8) A / 250 VAC
 10 (6) A / 250 VAC - 5E4
 10 (4) A / 400 VAC
 T125/55 °C
 EN 61058

20 A / 125 VAC
 16 A / 250 VAC
 3/4 HP - 125 / 250 VAC
 T105 °C
 UL 1054

Function 7 - L
 16 (6) A / 250 VAC
 10 (4) A / 400 VAC
 10 (4) A / 250 VAC - 5E4
 T125/55 °C
 EN 61058

20 A / 125 VAC
 16 A / 250 VAC
 3/4 HP - 125 / 250 VAC
 T105 °C
 UL 1054

Function 8 - W
 20 (2) A / 250 VAC *
 16 (8) A / 250 VAC
 10 (6) A / 250 VAC - 5E4
 T125/55 °C
 EN 61058

20 A / 125 VAC
 16 A / 250 VAC
 3/4 HP - 125 / 250 VAC
 T105 °C
 UL 1054

Function 9
 16 (6) A / 250 VAC
 10 (4) A / 250 VAC - 5E4
 T125/55 °C
 EN 61058

16 A / 125 VAC
 16 A / 250 VAC
 3/4 HP - 125 / 250 VAC
 T105 °C
 UL 1054

B

Function 8 - W
 20 (2) A / 250 VAC *
 16 (8) A / 250 VAC
 10 (6) A / 250 VAC - 5E4
 T125/55 °C
 EN 61058

16 A / 250 VAC
 3/4 HP - 250 VAC
 T105 °C
 UL 1054

* Not available for terminal 2

1 black

2 white

X custom

1 black

2 white

ILLUMINATED

G red

H orange

E green

L white

F blue

X custom

1 black

2 white

0 none

X custom

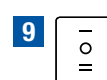
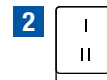
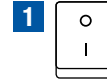

0 none

ILLUMINATED

G red

H orange

E green

X custom



SX83



TYPICAL APPLICATIONS Small appliances

FUNCTIONS

- Double SPST, illuminated or not
- Double SPDT
- SPST, illuminated or not + Indicator light
- SPST + SPCO

CYCLE No. 50.000

CUT OUT 30x22 mm

AMBIENT TEMPERATURE 125 °C

GWT 850 °C

GWT NO FLAME (<2sec) 750 °C on demand

S X 8 3

DRAWING

?

TERMINAL

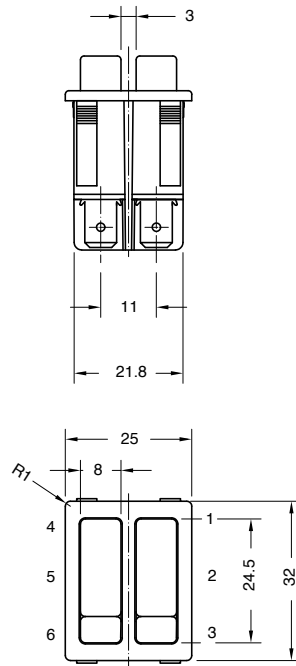

1

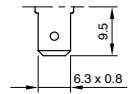

P (1 + waterproof cap mounted)

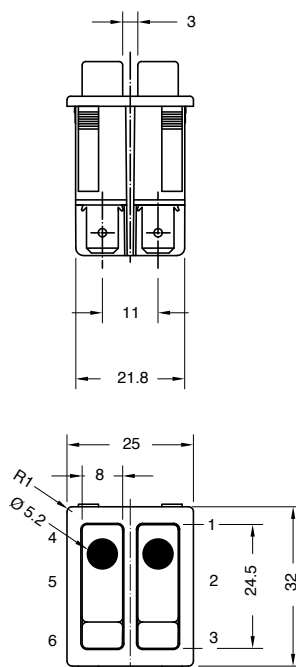

3

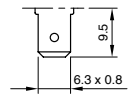

Q (3 + waterproof cap mounted)

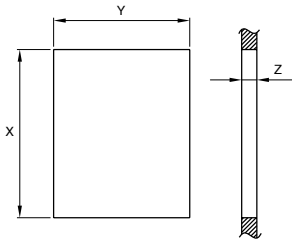

	Z	Y	X
PLASTIC	0,7 ... 3,5	22 ±0,1	30 +0,2 0
METAL	0,7 ... 2,5	22 ±0,1	30,2 +0,2 0

TERMINAL	FUNCTION	RATING	BODY COLOUR	ROCKER COLOUR L	ROCKER COLOUR R	MARKING COLOUR	MARKING L	MARKING R	LENS COLOUR
S	X	8	3						

?	?	?	L ? R ?	?	L ? R ?	?
FUNCTION	RATING	BODY COLOUR	ROCKER COLOUR	MARKING COLOUR	MARKING	LENS COLOUR

0	0
---	---

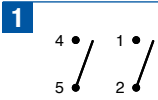

8
Function 1
 20 (2) A / 250 VAC
 16 (8) A / 250 VAC
 10 (4) A / 400 VAC
 10 (6) A / 250 VAC - 5E4
 T125/55 °C
 EN 61058

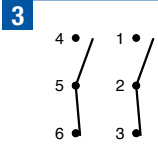

20 A / 125 VAC
 16 A / 250 VAC
 3/4 HP - 125 / 250 VAC
 T105 °C
 UL 1054

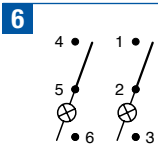

Function 3
 16 (8) A / 250 VAC
 10 (4) A / 400 VAC
 10 (6) A / 250 VAC - 5E4
 T125/55 °C
 EN 61058

20 A / 125 VAC
 16 A / 250 VAC
 3/4 HP - 125 / 250 VAC
 T105 °C
 UL 1054

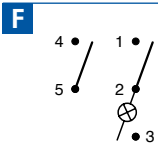

Function W - 6
 20 (2) A / 250 VAC
 16 (8) A / 250 VAC
 10 (6) A / 250 VAC - 5E4
 T125/55 °C
 EN 61058

20 A / 125 VAC
 16 A / 250 VAC
 3/4 HP - 125 / 250 VAC
 T105 °C
 UL 1054

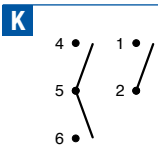

A
Function R
 20 (2) A / 250 VAC
 16 (8) A / 250 VAC
 10 (6) A / 250 VAC - 5E4
 T125/55 °C
 EN 61058

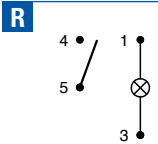

B
Function 6 - F
 20 (2) A / 250 VAC
 16 (8) A / 250 VAC
 10 (6) A / 250 VAC - 5E4
 T125/55 °C
 EN 61058

16 A / 250 VAC
 3/4 HP - 250 VAC
 T105 °C
 UL 1054

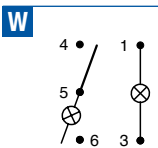

D
Function K
 16 (6) A / 250 VAC
 10 (4) A / 250 VAC - 5E4
 T125/55 °C
 EN 61058

- 1** black
- 2** white
- X** custom

- 1** black
- 2** white

ILLUMINATED

- G** red
- H** orange
- E** green

- X** custom

- 0** none
- 1** black
- 2** white
- X** custom

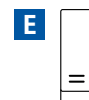
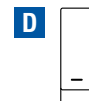
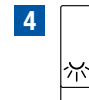
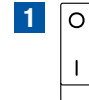
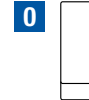

- 0** none

ILLUMINATED

- G** red
- H** orange
- E** green
- X** custom



SXD1

TYPICAL APPLICATIONS Coffee makers, electric fryers, crêpes machines, ironing steam generators

FUNCTIONS

- SPST, momentary or not
- SPST, illuminated or not version with led light available

CYCLE No. 50.000

CUT OUT See drawing

AMBIENT TEMPERATURE 125 °C

GWT 850 °C

GWT NO FLAME (<2sec) 750 °C on demand



S X D 1 ?

DRAWING

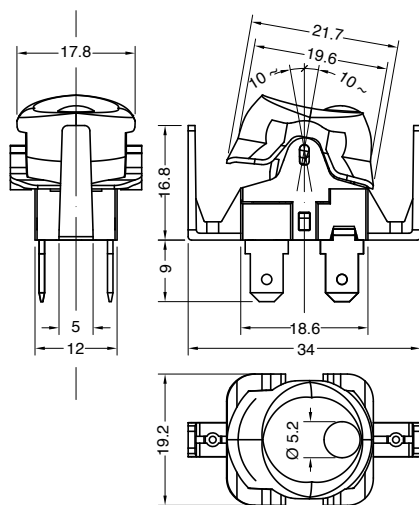

Cut out

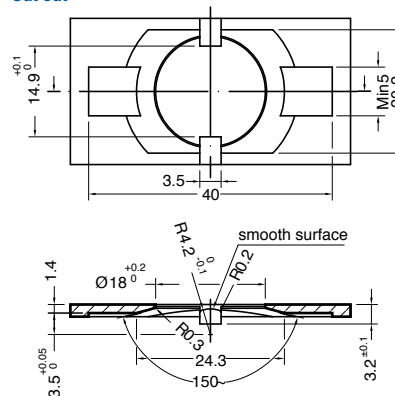

1

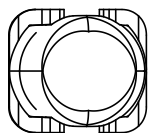

2

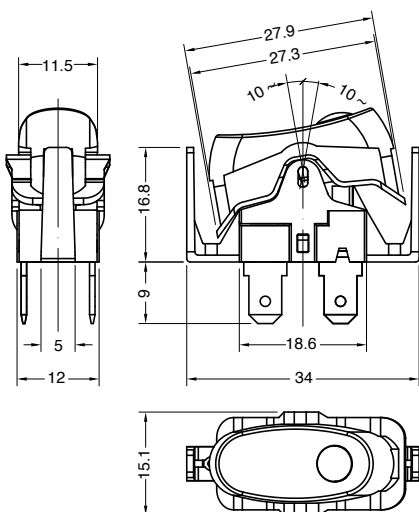
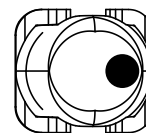

Cut out

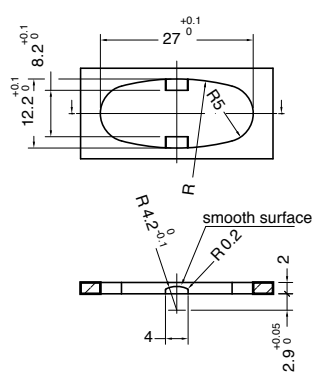

3

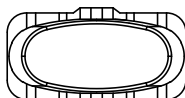

4

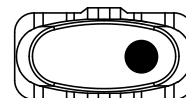

C

Custom rocker shape

S	X	D	1							0	0	0
				DRAWING	TERMINAL	FUNCTION	RATING	ROCKER COLOUR	LENS COLOUR	CUSTOM SHAPE		

?	?	?	?	?	?	?	?	?	?	?	0	0	0
TERMINAL	FUNCTION	RATING	ROCKER COLOUR	LENS COLOUR	CUSTOM SHAPE								

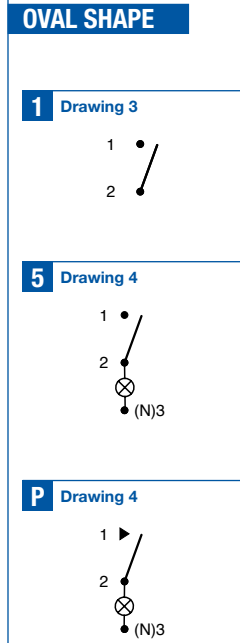
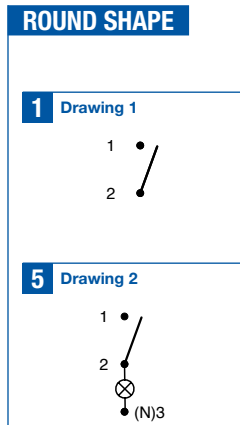
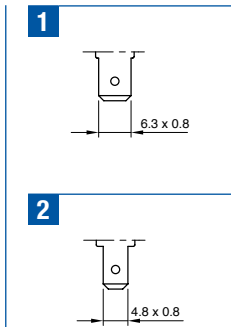

A

Function 1-5
16 (4) A / 250 VAC
10 (8) A / 250 VAC - 5E4
T125/55 °C
EN 61058

Function P
12 (6) A / 250 VAC
8 (4) A / 250 VAC - 5E4
T125/55 °C
EN 61058

B

Function 1-5
 16 A / 125 VAC
 1 HP / 125 VAC
 T105 °C
 UL 1054

C

Function 1-5
16 (4) A / 250 VAC
T125/55 °C
EN 61058

16 A 125 / 250 VAC
 1 HP 125 / 250 VAC
 T105 °C
 UL 1054

Function P
12 (6) A / 250 VAC
T125/55 °C
EN 61058

12 A 125 / 250 VAC
 1/2 HP 125 / 250 VAC
 T105 °C
 UL 1054

E

Function 1-5
 16 A / 250 VAC
 1 HP / 250 VAC
 T105 °C
 UL 1054

1 black

2 white

X custom

0 none

ILLUMINATED

G red

H orange

L white

E green

X custom

0 none

X custom

Push-Button Switches

01



SXL4

72



DY1

86



SCA

74



DY2

88



P1

76



**DY
Accessories**

90



SP60

78



SPM

92



SP63

80



TOUCH

94



SXL5

82



RFIT

96



LITE

84



SXL4

TYPICAL APPLICATIONS Coffee machines, washing machines

- FUNCTIONS**
- SPST, momentary or not
 - SPST, illuminated or not
 - DPST, momentary or not
 - DPST, illuminated or not

CYCLE No. 50.000

CUT OUT 19x13 mm

AMBIENT TEMPERATURE 125 °C

GWT 850 °C

GWT NO FLAME (<2sec) 750 °C



S X L 4 ?

?

DRAWING

TERMINAL



1 FLAT

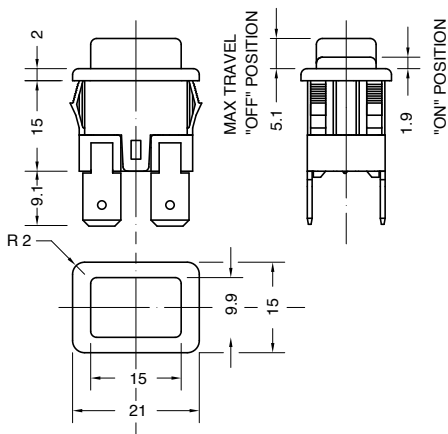

1 Drawing 1 - 2 - 3 Vertical terminal 6.3x0.8



A Drawing 1 Horizontal terminal 6.3x0.8



2 BOWL

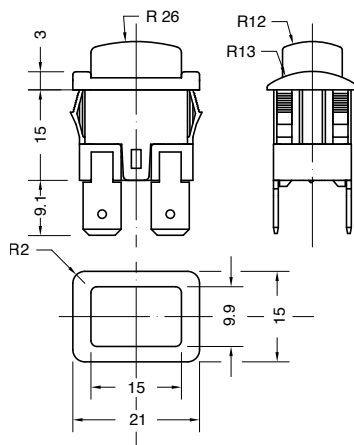

2 Drawing 1 - 2 - 3 Vertical terminal 4.8x0.8



B Drawing 1 - 3 Horizontal terminal 4.8x0.8



3 CUSTOMIZABLE

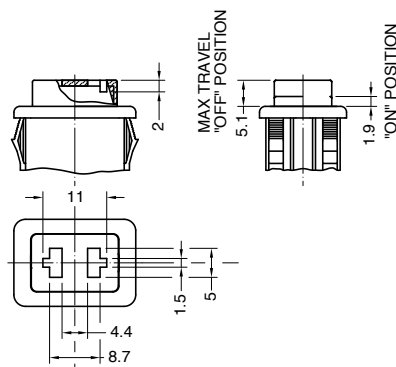

4 Drawing 1 - 2 Vertical PCB terminal



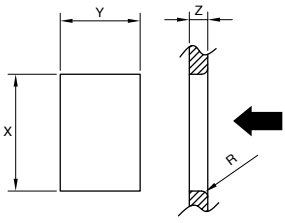

Z	Y	X
0,5-1,2	12,9 ^{+0,1} ₀	19,0 ^{+0,2} ₀
1,2-2,0	12,9 ^{+0,1} ₀	19,3 ^{+0,2} ₀
2,0-3,0	12,9 ^{+0,1} ₀	19,6 ^{+0,2} ₀

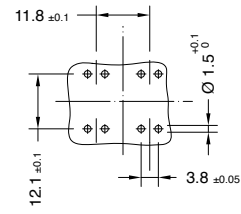
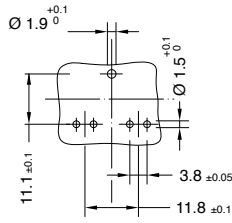

DRAWING	TERMINAL	FUNCTION	RATING	BODY COLOUR	BUTTON COLOUR	MARKING COLOUR	MARKING
S	X	L	4				
							0 0 0 W

?	?	?	?	?	?	0	0	0	W
---	---	---	---	---	---	---	---	---	---

FUNCTION RATING BODY COLOUR BUTTON COLOUR MARKING COLOUR MARKING

1

2

4

6 No drawing 3

7

8 No drawing 3

H

16 (4) A / 250 VAC
 10 (6) A / 250 VAC - 5E4
 T125/55 °C
 EN 61058

16 A - 125 / 250 VAC
 3/4 HP - 125 / 250 VAC
 T100 °C
 UL 1054

9

12 (8) A / 250 VAC - 5E4
 T85/55 °C
 EN 61058

1 black

2 white

X custom

Drawing 1 - 3

1 black

2 white

Drawing 1 - 2

M white

N black

R red

0 none

1 black

2 white

X custom

0

1

R

X

ILLUMINATED

G red

H orange

E green

L white

F blue

X custom



SCA



FUNCTION

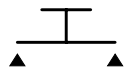

TYPICAL APPLICATIONS Ironing systems

FUNCTIONS ■ SPST momentary

CYCLE No. 50.000

CUT OUT 19x13 mm

AMBIENT TEMPERATURE 120 °C

GWT 850 °C

GWT NO FLAME (<2sec) 750 °C on demand

?

TERMINAL

0

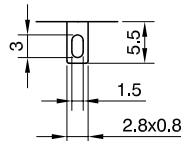

4

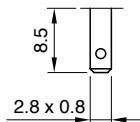

?

RATING

2

2 (1) A / 250 VAC
1 (0.5) A / 250 VAC - 5E4
T120 °C
EN 61058

2 A - 125 / 250 VAC
T65 °C
UL 1054
CSA C22.2

4

6 (4) A / 250 VAC
5 (2) A / 250 VAC - 5E4
T120 °C
EN 61058

6

10 (4) A / 250 VAC
5 (2) A / 250 VAC - 5E4
T120 °C
EN 61058

6 A - 125 / 250 VAC
1/6 HP - 250 VAC
1/8 HP - 125 VAC
T65 °C
UL 1054
CSA C22.2

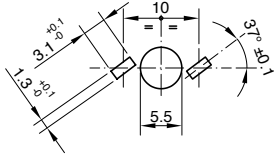
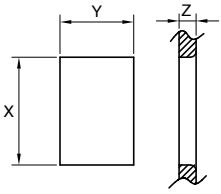

Z	Y	X
0,70 ... 1,25	13,0 ±0,1	19,0 ±0,1
1,25 ... 2,0	13,0 ±0,1	19,3 ±0,2
2,0 ... 3,0	13,0 ±0,1	19,6 ±0,2

0	5	8	4	TERMINAL	RATING	DRAWING	BODY COLOUR	BUTTON COLOUR	MARKING COLOUR	MARKING	0	0
---	---	---	---	----------	--------	---------	-------------	---------------	----------------	---------	---	---

?	?	?	?	?	?	?	?	?	?	?	0	0
---	---	---	---	---	---	---	---	---	---	---	---	---

DRAWING **BODY COLOUR** **BUTTON COLOUR** **MARKING COLOUR** **MARKING**

A Mat

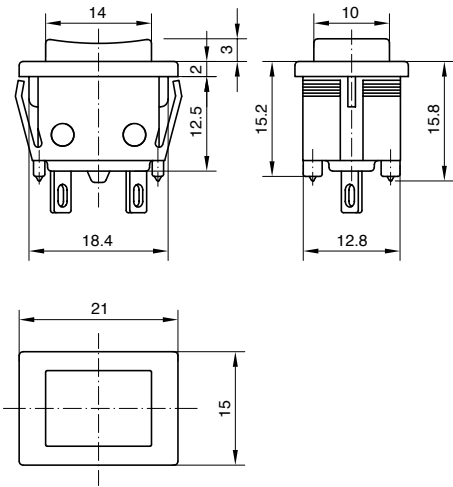

B Gloss

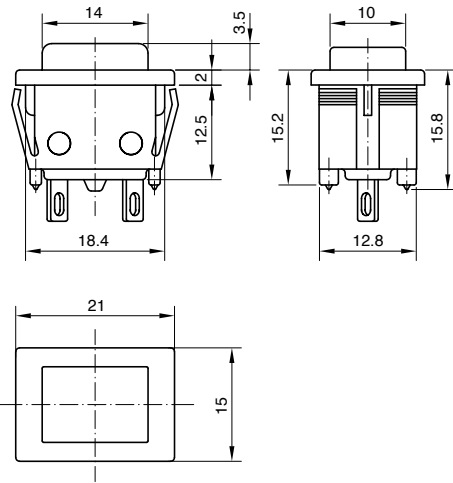

1 black

2 white

X ? custom

1 black

2 white

X ? custom

0 none

1 black

2 white

X ? custom

0

X ?

0

X ?

0

X ?

0

X ?

0

X ?

0



P1

TYPICAL APPLICATIONS Cooking, small appliances, HVAC

FUNCTIONS

- SPST momentary, illuminated or not
- DPST momentary

CYCLE No. 50.000

CUT OUT ø 16 mm

AMBIENT TEMPERATURE 125 °C

GWT 850 °C

GWT NO FLAME (<2sec) 750 °C on demand



P

1

?

DRAWING



WATERPROOF CAP

2

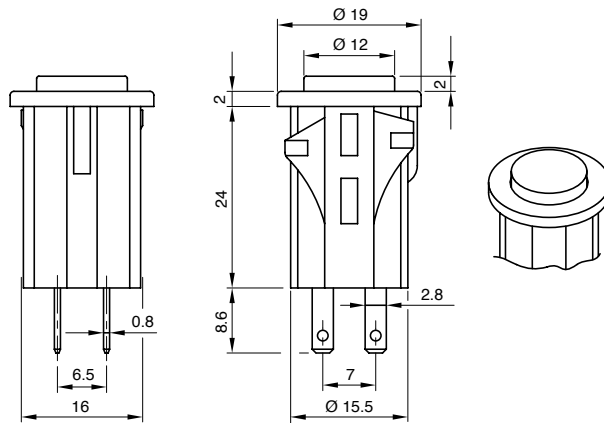

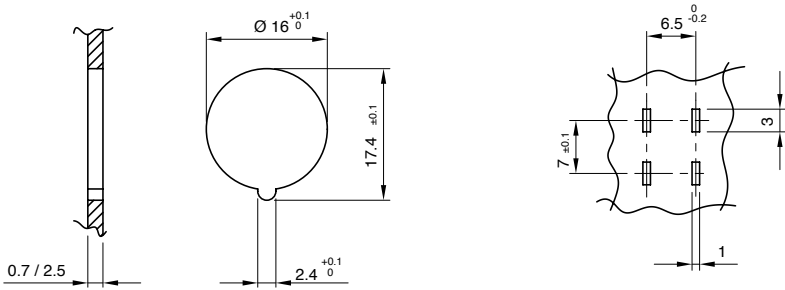

P	1	DRAWING	FUNCTION	RATING	BODY COLOUR	BUTTON COLOUR	MARKING COLOUR	MARKING	0	0	0
---	---	---------	----------	--------	-------------	---------------	----------------	---------	---	---	---

?	?	?	?	?	?	?	?	?	0	0	0
---	---	---	---	---	---	---	---	---	---	---	---

FUNCTION **RATING** **BODY COLOUR** **BUTTON COLOUR** **MARKING COLOUR** **MARKING**

4

7

N

P

3
 3 (1) A / 250 VAC
 0.5 A / 250 VAC - 5E4
 T125 °C
 EN 61058

On demand
 2A/125 VAC
 T65 °C
 UL 1054

1
 black

2
 white

X **?**
 custom

1
 black

2
 white

5
 grey

9
 red

ILLUMINATED

G
 red

X **?**
 custom

0
 none

1
 black

2
 white

X **?**
 custom

0

7

8

X **?**



SP60

TYPICAL APPLICATIONS Vacuum and steam cleaners

FUNCTIONS

- SPST, momentary or not
- SPST, illuminated or not
- DPST, illuminated or not

CYCLE No. 50.000

CUT OUT \varnothing 25 mm

AMBIENT TEMPERATURE 120 °C

GWT 850 °C

GWT NO FLAME (<2sec) 750 °C on demand



S P 6 0

?

DRAWING

TERMINAL



WATERPROOF CAP

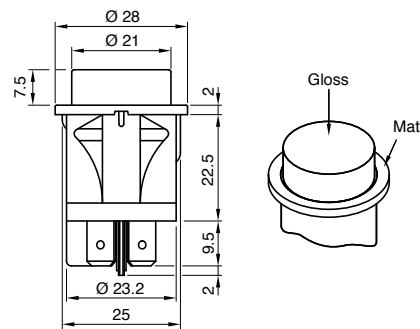

1

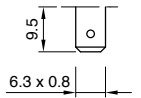

A

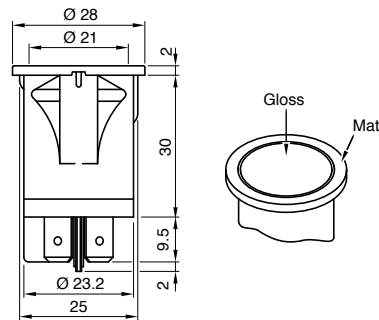
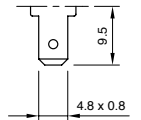

2

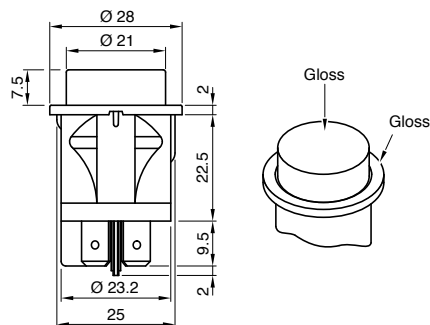
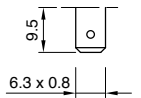

4

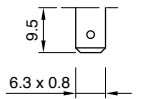

D

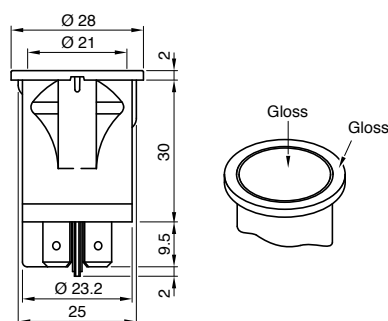
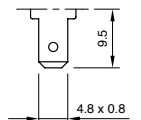

5

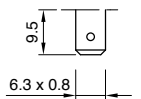

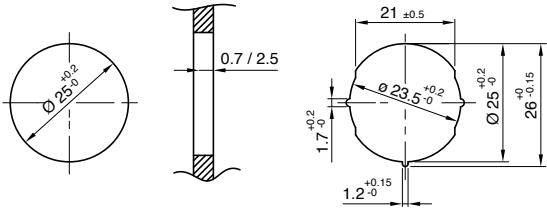

S	P	6	0	TERMINAL	FUNCTION	RATING	BODY COLOUR	BUTTON COLOUR	MARKING COLOUR	MARKING	0	0
---	---	---	---	----------	----------	--------	-------------	---------------	----------------	---------	---	---

?	?	?	?	?	?	?	0	0
---	---	---	---	---	---	---	---	---

FUNCTION RATING BODY COLOUR BUTTON COLOUR MARKING COLOUR MARKING

1

2

4

6

8

7

16 (6) A / 250 VAC
 10 (4) 250 VAC - 5E4
 10 (4) A / 400 VAC
 T120/55 °C
 EN 61058

16 A - 125 / 250 VAC
 1/4 HP / 125 VAC
 1/2 HP / 250 VAC
 T95 °C
 UL 1054

C

16 (6) A / 250 VAC
 10 (4) 250 VAC - 5E4
 10 (4) A / 400 VAC
 T120/55 °C
 EN 61058

1

black

2

white

X

custom

M

white

N

black

R

red

ILLUMINATED

G

red

H

orange

E

green

L

white

X

custom

No lens

0

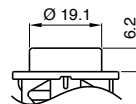

0

none

1

black

2

white

X

custom

0

7

D

E

K

X

ACCESSORIES



SP60T1N0000



SP60T1M0000



SP60T1G0000



SP60T1E0000

Other colours available on demand.



SP63

TYPICAL APPLICATIONS Vacuum and steam cleaners

FUNCTIONS

- SPST, momentary or not
- SPST, illuminated or not
- DPST illuminated

CYCLE No. 50.000

CUT OUT 27x22 mm

AMBIENT TEMPERATURE 120 °C

GWT 850 °C

GWT NO FLAME (<2sec) 750 °C on demand



S

P

6

3

?

DRAWING

TERMINAL

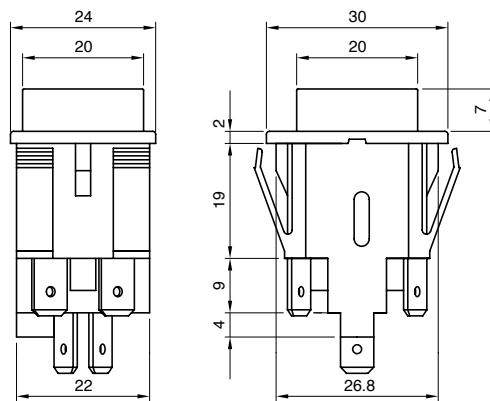

1

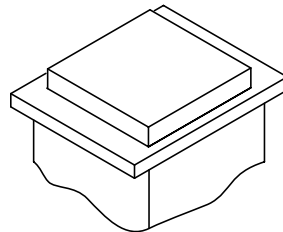
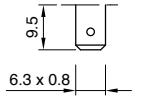

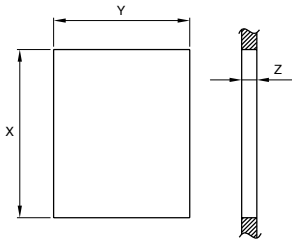

Z	Y	X
0,7 ... 2,5	22,2 ^{+0,3} ₀	27,2 ^{+0,3} ₀

S	P	6	3	TERMINAL	FUNCTION	RATING	BODY COLOUR	BUTTON COLOUR	MARKING COLOUR	MARKING	0	0

?	?	?	?	?	?	?	0	0
---	---	---	---	---	---	---	---	---

FUNCTION **RATING** **BODY COLOUR** **BUTTON COLOUR** **MARKING COLOUR** **MARKING**

4

6

8

N

C
 16 (6) A / 250 VAC
 10 (4) A / 250 VAC - 5E4
 10 (4) A / 400 VAC
 T120 °C
 EN 61058

1 black
X custom

M white
N black
R red

ILLUMINATED

G red
H orange
E green
L white

X custom

No lens

0

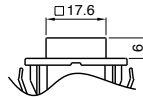

0 none
1 black
2 white
X custom

0

4

7

X

ACCESSORIES



SP63T1E0000



SP63T1G0000



SP63T1H0000

Other colours available on demand.



SXL5

TYPICAL APPLICATIONS	Vacuum cleaners, washing machines, dishwashers, hydrocleaners
FUNCTIONS	<ul style="list-style-type: none"> ■ SPST, momentary or not ■ DPST, momentary or not
CYCLE No.	50.000
CUT OUT	Rear panel
AMBIENT TEMPERATURE	125 °C
GWT	850 °C
GWT NO FLAME (<2sec)	750 °C



TRAVEL POSITION

OFF position

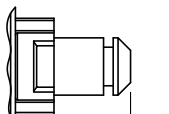

Max travel

5,1 ±0,2

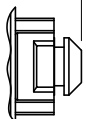

ON position

3,2 ±0,2



DRAWING

1

Vertical tab terminals

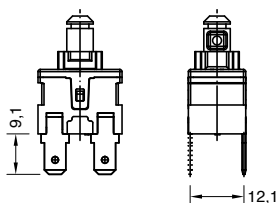

Vertical PCB terminals

Single pole version

Double pole version

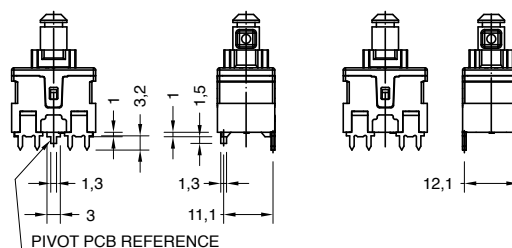

Horizontal tab terminals

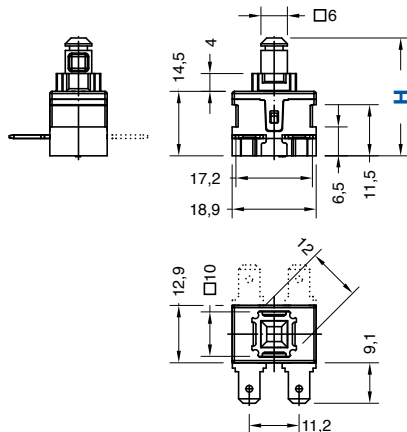

Horizontal PCB terminals

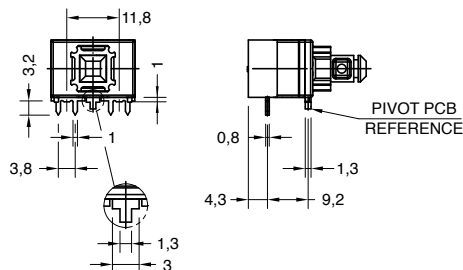

2

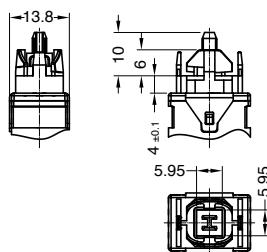

Wings fixing

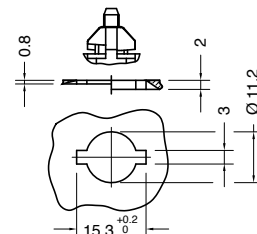

3

Single pole version

Double pole version

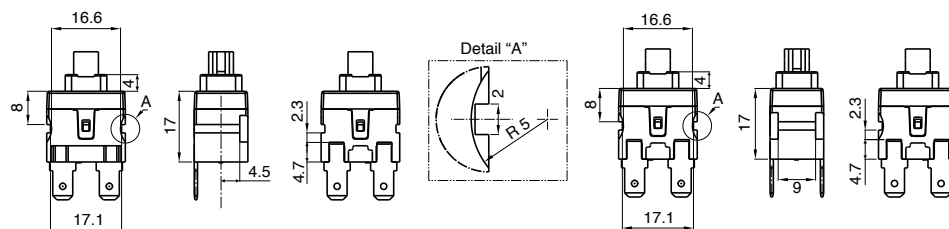

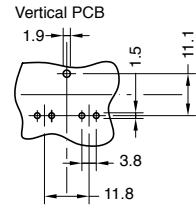
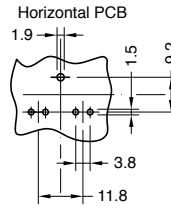
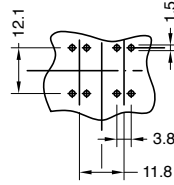
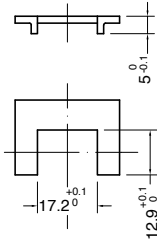
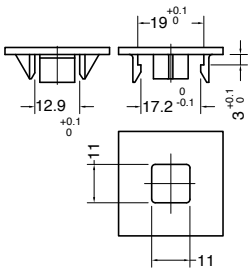

DRAWING TERMINAL SHAFT FUNCTION RATING

S	X	L	5						0	0	0	W
---	---	---	---	--	--	--	--	--	---	---	---	---

?

TERMINAL

1 Drawing 1 - 2 - 3
Vertical terminal
6.3x0.8



A Drawing 1 - 3
Horizontal terminal
6.3x0.8



2 Drawing 1 - 2 - 3
Vertical terminal
4.8x0.8



B Drawing 1 - 3
Horizontal terminal
4.8x0.8

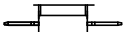

4 Drawing 1 - 2
Vertical PCB terminal



D Drawing 1
Horizontal PCB
terminal
only function 1 - 4



?

SHAFT

A H = 26.5
Available with drawings 1 and 2

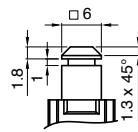

B H = 28.5

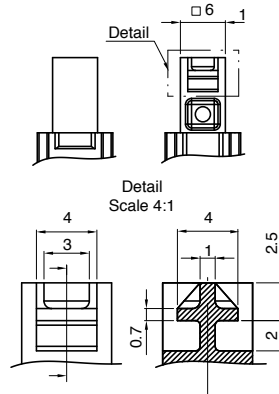

C H = 24
Available with drawings 1 and 2

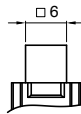

D H = 28.5

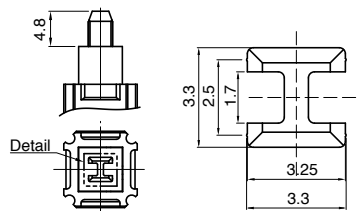

E H = 26.5

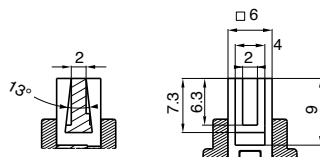

?

FUNCTION

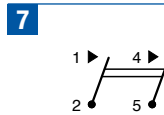
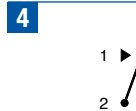
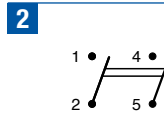

?

RATING

H
12 (8) A / 250 VAC
16 (4) A / 250 VAC
10 (6) A / 250 VAC - 5E4
T125/55 °C
EN 61058 / CQC

16 A - 125 / 250 VAC
3/4 HP - 125 / 250 VAC
T100 °C
UL 1054

9
12 (8) A / 250 VAC - 5E4
T85/55 °C
EN 61058

16 A - 125 / 250 VAC
3/4 HP - 125 / 250 VAC
T100 °C
UL 1054

0	0	0	W
---	---	---	---



LITE

TYPICAL APPLICATIONS Coffee machines

FUNCTIONS ■ SPST, illuminated or not
■ DPST illuminated

CYCLE No. 50.000

CUT OUT 19x13 mm rear panel

AMBIENT TEMPERATURE 125 °C

GWT 850 °C

GWT NO FLAME (<2sec) 750 °C



L I T E ?

DRAWING

1

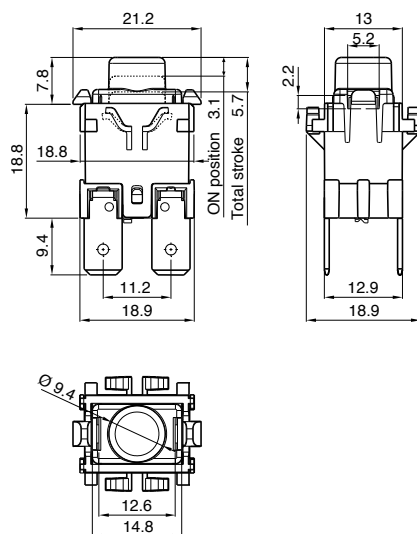

?

TERMINAL

1 Vertical terminal
6.3x0.8



2 Vertical terminal
4.8x0.8



A Horizontal terminal
6.3x0.8



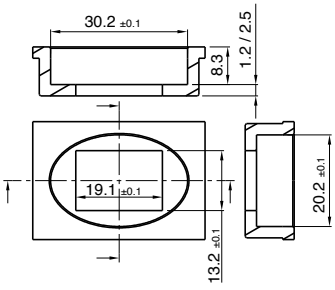

L	I	T	E	DRAWING	TERMINAL	AESTHETIC	FUNCTION	RATING	LENS COLOUR	LAMP COLOUR	0	0	0

?	?	?	?	?	0	0	0
---	---	---	---	---	---	---	---

AESTHETIC

FUNCTION

RATING

LENS COLOUR

LAMP COLOUR

A

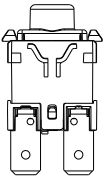

1



5



8

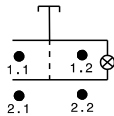

C

16 (6) A / 250 VAC
12 (10) A / 250 VAC
8 (8) A / 250 VAC - 5E4
T125/55 °C
EN 61058

16 A - 125 / 250 VAC
1/2 HP - 125 VAC
3/4 HP - 250 VAC
T100 °C
UL 1054

L

colourless

O

no lamp

G

red

E

green

ACCESSORIES



LITET1N0000



LITET1M0000



LITET1E0000



LITET1G0000

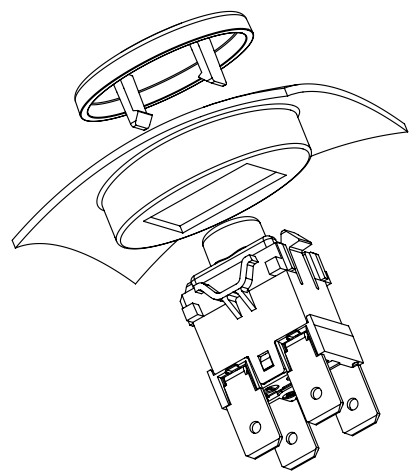
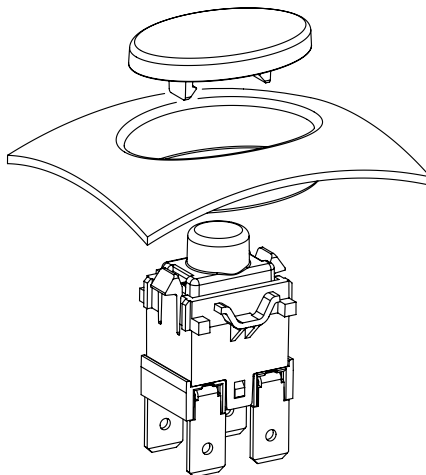



DY1

TYPICAL APPLICATIONS	Cooking, washing, coffee machines
FUNCTIONS	<ul style="list-style-type: none"> ■ SPST, momentary or not ■ SPDT, momentary or not
CYCLE No.	50.000
CUT OUT	Rear panel
AMBIENT TEMPERATURE	125 °C
GWT	850 °C
GWT NO FLAME (<2sec)	750 °C



D **Y** **1**

DRAWING

?

TERMINAL

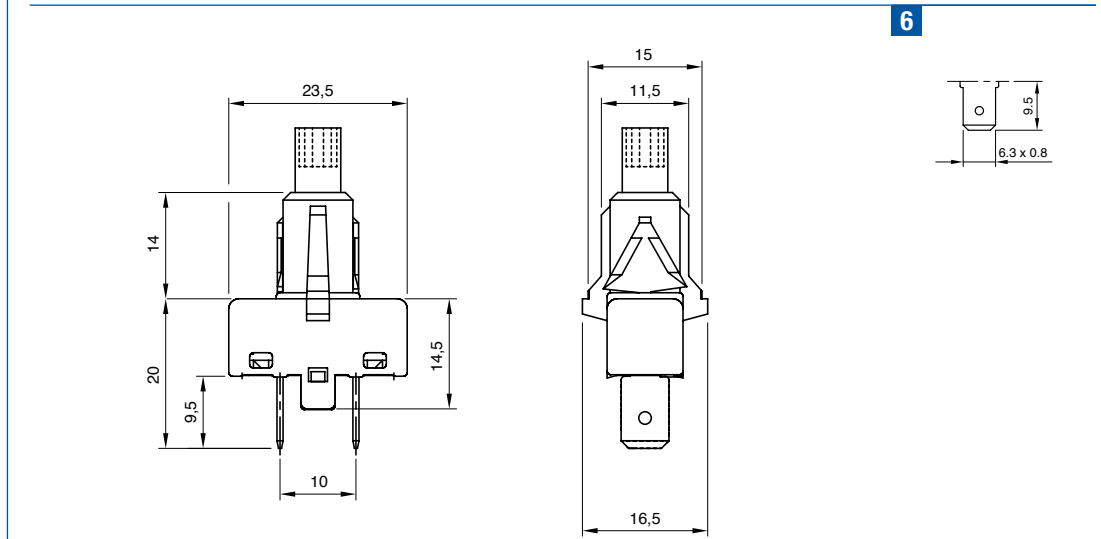
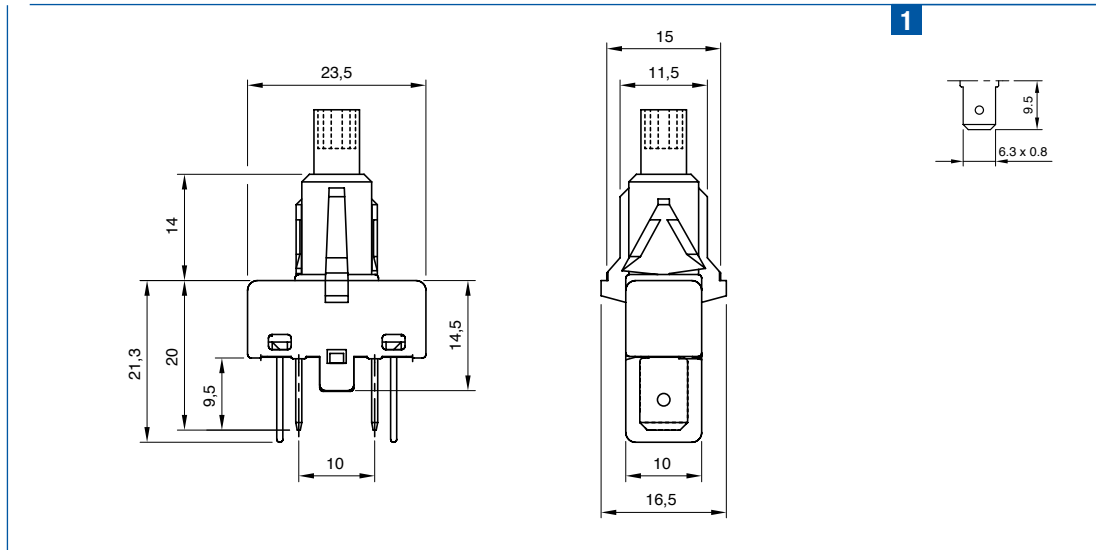

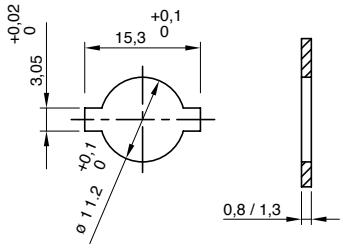

	TERMINAL	SHAFT	LATCHING FUNCTION	FUNCTION	RATING			
D	Y	1				0	0	0

?

SHAFT

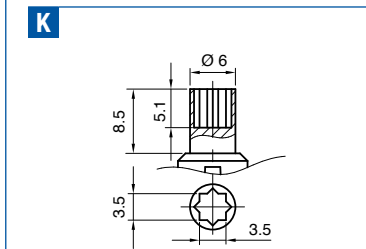
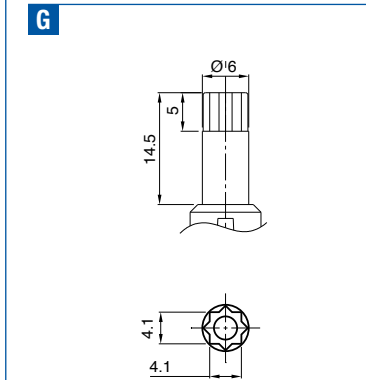
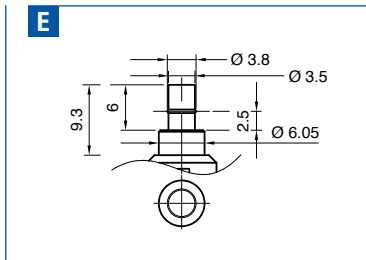

?

LATCHING FUNCTION

S Push to On - Push to Off



M Momentary



?

FUNCTION

10

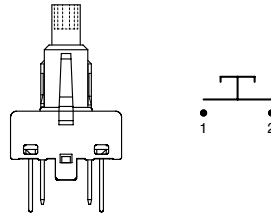

60

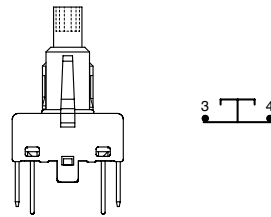

30

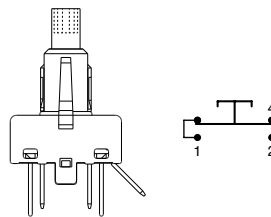

?

RATING

0 0 0

E
Function 10
 16 (6) A / 250 VAC
 10 (4) A / 250 VAC - 5E4
 T125/55 °C
 6 (2) A / 250 VAC
 T150/55 °C
 EN 61058

13 A / 250 VAC
 3/4 HP - 250 VAC
 1/3 HP - 125 VAC
 T65 °C
 UL 1054

Function 60
 16 (6) A / 250 VAC
 10 (4) A / 250 VAC - 5E4
 T125/55 °C
 EN 61058

13 A / 250 VAC
 3/4 HP - 250 VAC
 1/3 HP - 125 VAC
 T65 °C
 UL 1054

N
Function 30
 12 (4) A / 250 VAC
 10 (4) A / 250 VAC - 5E4
 T125/55 °C
 μ disconnection
 EN 61058

13 A / 250 VAC
 3/4 HP - 250 VAC
 1/3 HP - 125 VAC
 T65 °C
 UL 1054



DY2



TYPICAL APPLICATIONS	Cooking, washing, coffee machines
FUNCTIONS	<ul style="list-style-type: none"> ■ DPST, momentary or not ■ SPST+SPDT, momentary or not
CYCLE No.	50.000
CUT OUT	Rear panel
AMBIENT TEMPERATURE	125 °C
GWT	850 °C
GWT NO FLAME (<2sec)	750 °C

D **Y** **2**

DRAWING

?

TERMINAL

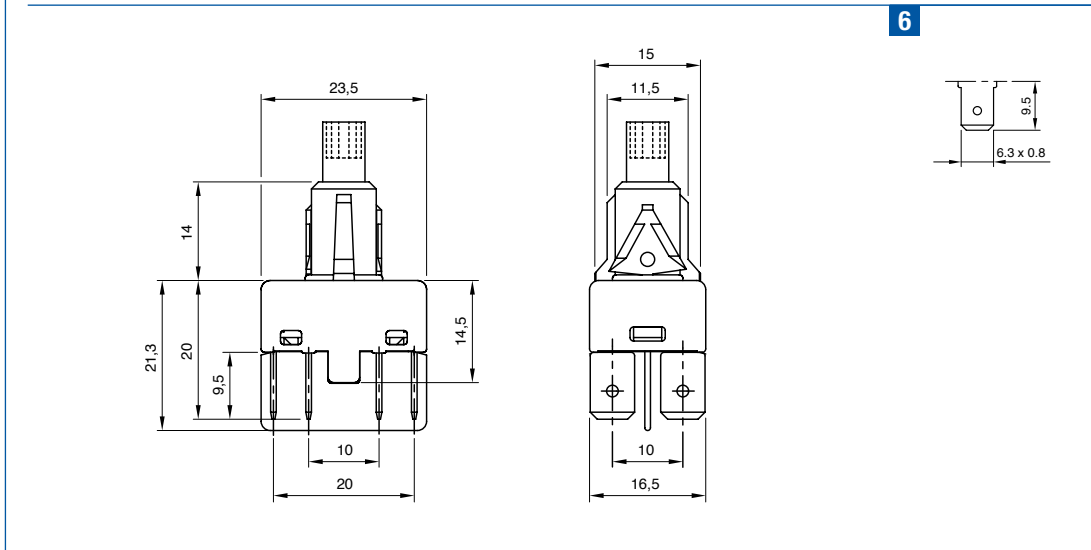
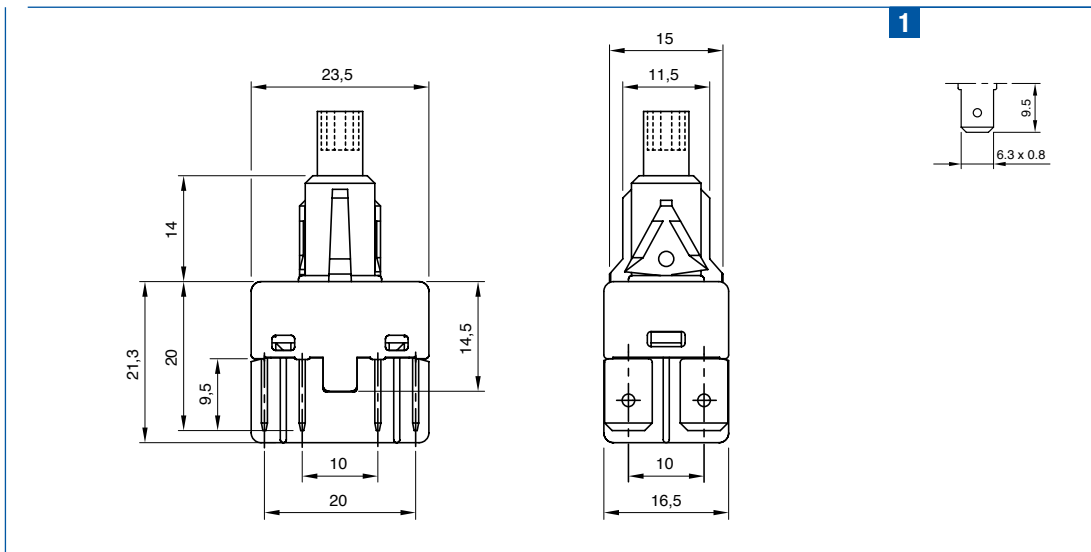

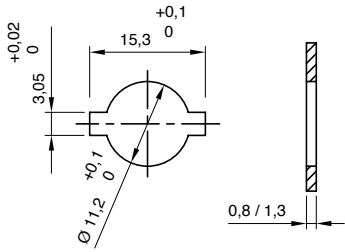

	TERMINAL	SHAFT	LATCHING FUNCTION	FUNCTION	RATING			
D	Y	2				0	0	0

?

SHAFT

?

LATCHING FUNCTION

? ?

FUNCTION

?

RATING

0 0 0

E

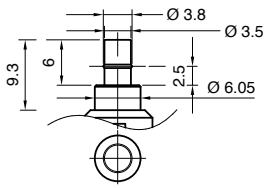

S Push to On - Push to Off



M Momentary



11

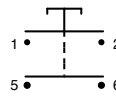
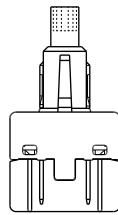

13

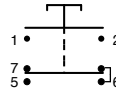
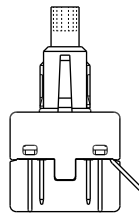

E

Function 11

16 (6) A / 250 VAC
10 (4) A / 250 VAC - 5E4
T125/55 °C
EN 61058

13 A / 250 VAC
3/4 HP - 250 VAC
1/3 HP - 125 VAC
T65 °C
UL 1054

P

Function 13

- Side switch (1-2)
16 (6) A / 250 VAC
10 (4) A / 250 VAC - 5E4
T125/55 °C
EN 61058

- Side changeover (5-6-7)
12 (4) A / 250 VAC
10 (4) A / 250 VAC - 5E4
T125/55 °C
µ disconnection
EN 61058

13 A / 250 VAC
T65 °C
UL 1054

K

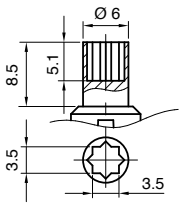



DYST

Accessories for DY series

TYPICAL APPLICATIONS Cooking, washing, coffee machines

CUT OUT See drawing

AMBIENT TEMPERATURE up to 125 °C

GWT 850 °C

D	Y	S	T	TYPE	BODY COLOUR	0	0	0	0
---	---	---	---	------	-------------	---	---	---	---

D	Y	S	T	?	?	0	0	0	0
---	---	---	---	---	---	---	---	---	---

CUT OUT

DRAWING

TYPE

BODY COLOUR



Oval body

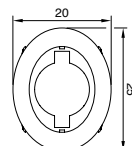
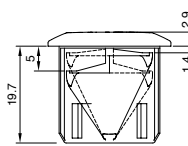
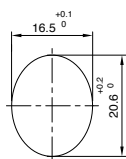

5 Standard

7 Painted

Standard

1 black

2 white

Painted

1 chrome

Round body with antirotation rib

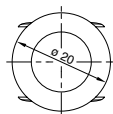
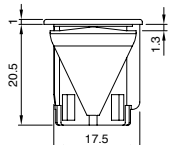
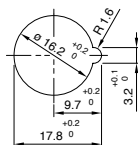

1 Standard

9 Painted

X ?
custom

Round body

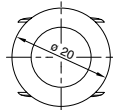
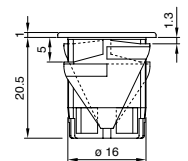

3 Standard

8 Painted

Soft Round body with antirotation rib

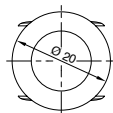
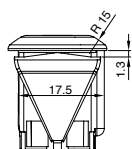
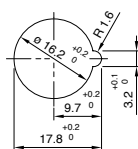

G Standard

S Painted

Soft Round body

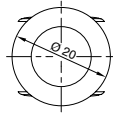
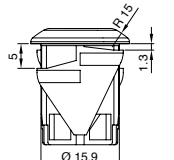

L Standard

T Painted



DYT

Accessories for DY series

TYPICAL APPLICATIONS	Cooking, washing, coffee machines
CUT OUT	See drawing
AMBIENT TEMPERATURE	55 °C
GWT	850 °C

D	Y	T						0	0

D	Y	T	?	?	?	?	?	0	0
---	---	---	---	---	---	---	---	---	---

DRAWING **TYPE** **BUTTON COLOUR** **MARKING COLOUR** **MARKING**



Oval button

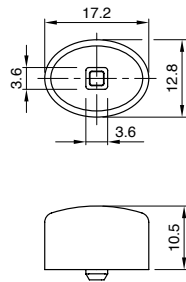

5K Standard

7K Painted

Standard

- 1** black
- 2** white

Painted

- 1** chrome

0
none

1 black

2 white

X custom

0



X



Round button

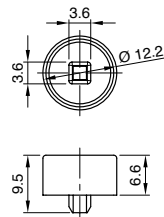

1K Standard

8K Painted

X custom

Soft Round button

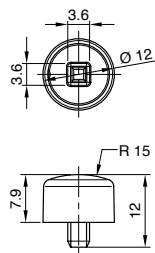

3K Standard

9K Painted



SPM



TYPICAL APPLICATIONS	Washing
FUNCTIONS	<ul style="list-style-type: none"> ■ SPST, momentary or not ■ SPDT ■ DPST, momentary or not ■ DPDT
CYCLE No.	50.000
CUT OUT	Rear panel
AMBIENT TEMPERATURE	125 °C
GWT	850 °C
GWT NO FLAME (<2sec)	750 °C (Rating C)

S P M

?

DRAWING

TERMINAL

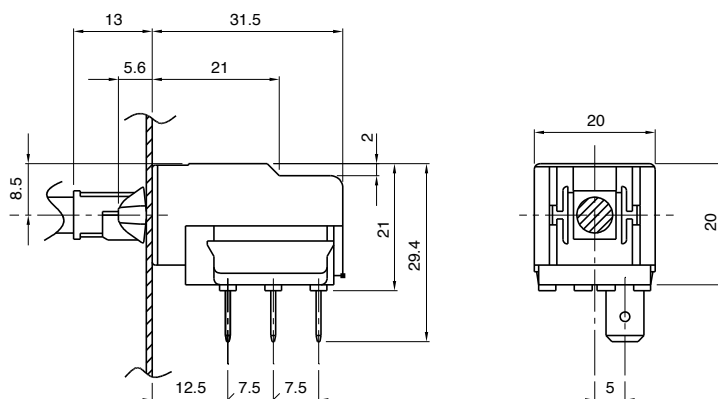

4

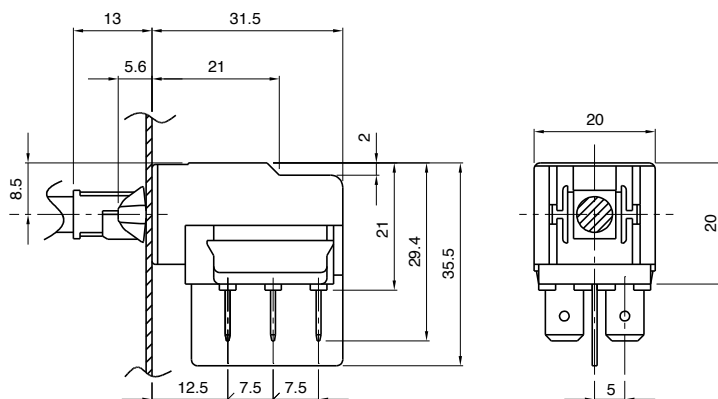
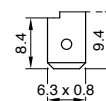

1

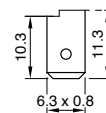

2

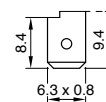

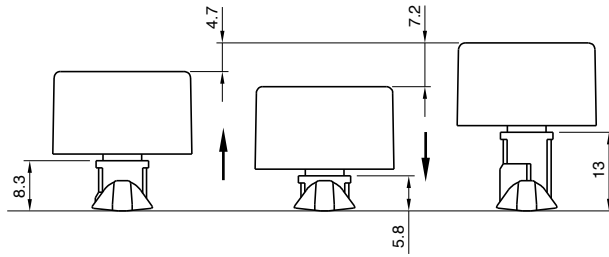
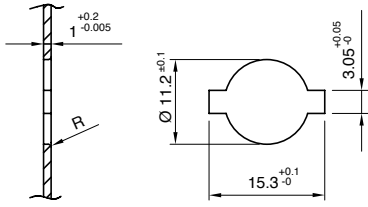

S	P	M	TERMINAL	SHAFT	FUNCTION	RATING
						0 0 0

?

SHAFT

?

FUNCTION

?

RATING

0

0

0

C

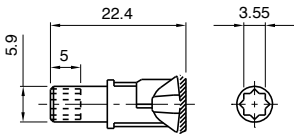

E

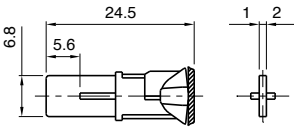

M

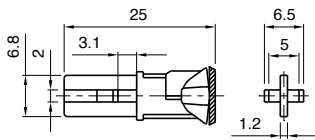

P

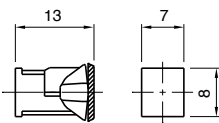

1



2

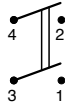

3

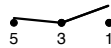

4



7



C



K



L

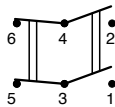

4

16 (8) A / 250 VAC
10 (6) A / 250 VAC - 5E4
10 A / 400 VAC
T125 °C
EN 61058

C

16 (8) A / 250 VAC
10 (6) A / 250 VAC - 5E4
10 A / 400 VAC
T125 °C
EN 61058

20 A / 125 VAC
16 A / 250 VAC
1/3 HP - 125 VAC
3/4 HP - 250 VAC
T65 °C
UL 1054
CSA C22.2

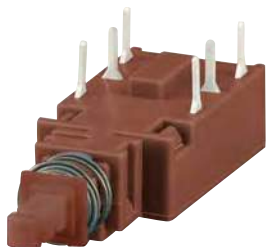

TOUCH

TYPICAL APPLICATIONS Cooker hoods, coffee machines, microwave

- FUNCTIONS**
- SPST, momentary or not
 - SPDT, momentary or not
 - DPST, momentary or not
 - DPDT, momentary or not

CYCLE No. 10.000

CUT OUT -

AMBIENT TEMPERATURE 110 °C

GWT 850 °C

GWT NO FLAME (<2sec) 750 °C



T O U C H

?

TERMINAL

4

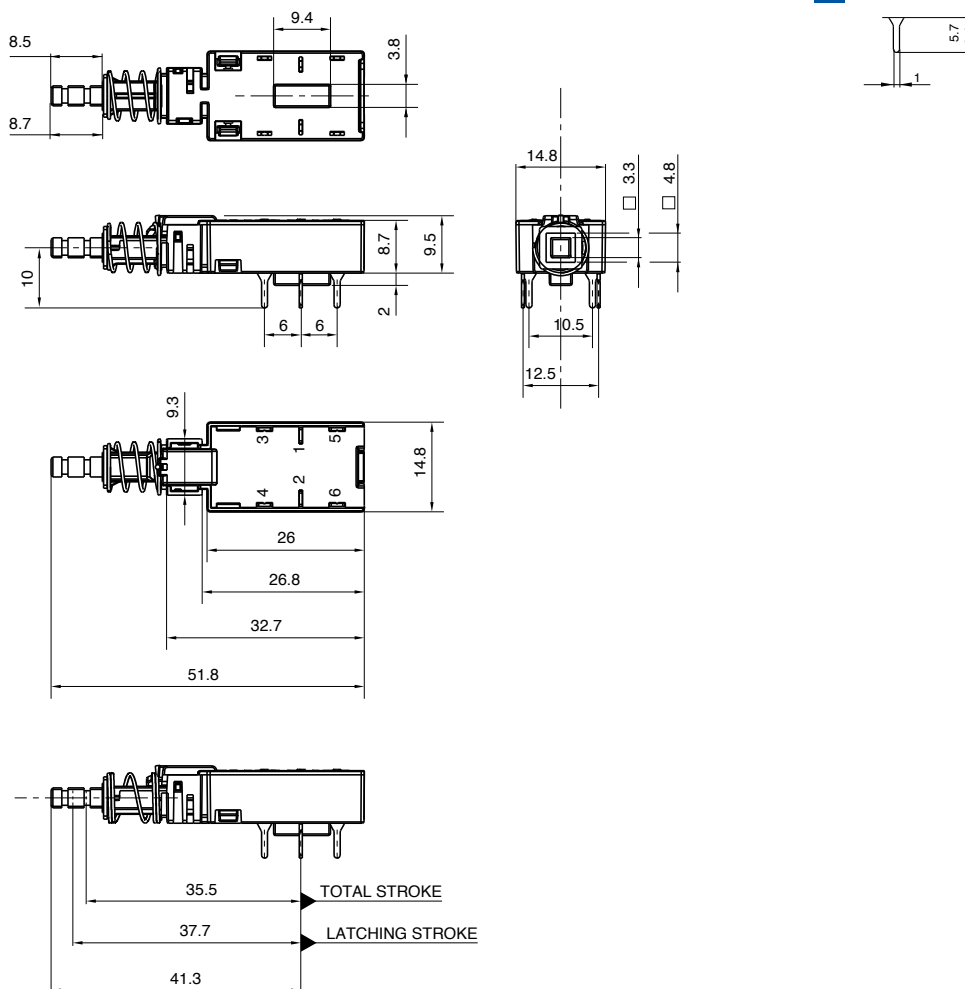

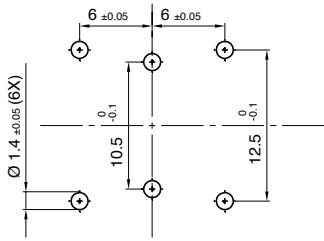

TERMINAL	SHAFT	FUNCTION	RATING								
T	O	U	C	H					0	0	W

?

SHAFT

A

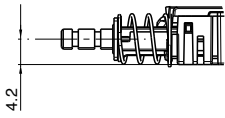

B

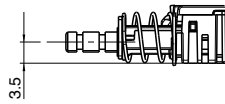

?

FUNCTION

1



2

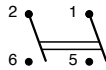

3



4



7

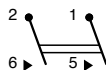

B



L

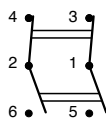

M

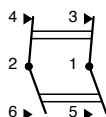

?

RATING

2

5 (2) A / 250 VAC
T85 °C
EN 61058

6 A / 125 VAC
T65 °C
UL 1054

3

8 (3) A / 250 VAC
T110 °C
EN 61058

6 A / 125 VAC
T65 °C
UL 1054

0

0

W



RFIT



TYPICAL APPLICATIONS	Coffee machines, washing machine
FUNCTIONS	<ul style="list-style-type: none"> ■ SPST, momentary or not ■ DPST, momentary or not ■ DPST, illuminated or not
CYCLE No.	50.000
CUT OUT	ø 20 mm
AMBIENT TEMPERATURE	125 °C
GWT	850 °C
GWT NO FLAME (<2sec)	750 °C on demand

R F I T ?

DRAWING

?

TERMINAL



1

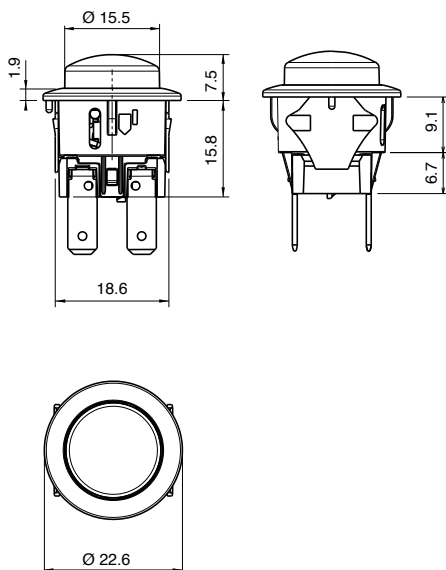

2

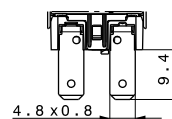

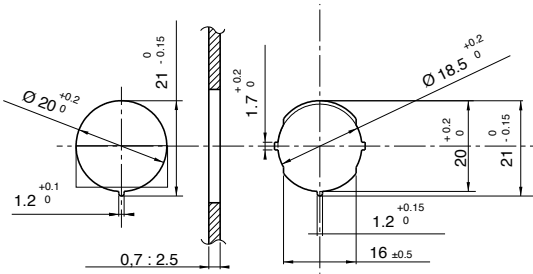

DRAWING	TERMINAL	FUNCTION	RATING	BODY COLOUR	BUTTON COLOUR	0	0	0	0	0
R	F	I	T							

?

FUNCTION

- 1**
- 2**
- 4**
- 7**
- 8**

?

RATING

- C**
16 (6) A / 250 VAC
12 (10) A / 250 VAC
8 (8) A / 250 VAC - 5E4
T125 / 55 °C
EN 61058
- 16 A - 125 / 250 VAC
1 / 2 HP - 125 VAC
3 / 4 HP - 250 VAC
T65 °C (T100 °C on demand)
UL 1054

?

BODY COLOUR

- 1** black
- 2** white

?

BUTTON COLOUR

- N** black
- M** white

0 0 0 0 0

ILLUMINATED

- E** green
- F** blue
- G** red
- H** orange
- X** custom

Waterproof Switches

01



SXL44

100



B4MASK

102



SXA4

104



RMASK

106



SXLR

108



SXL44



TYPICAL APPLICATIONS Steam cleaners

FUNCTIONS

- SPST, momentary or not
- SPST, illuminated or not
- DPST, momentary or not
- DPST, illuminated or not

PROTECTION DEGREE IP 65

CYCLE No. 50.000

CUT OUT 19x13 mm

AMBIENT TEMPERATURE 125 °C

GWT 850 °C

GWT NO FLAME (<2sec) 750 °C on demand

S X L 4 4

DRAWING

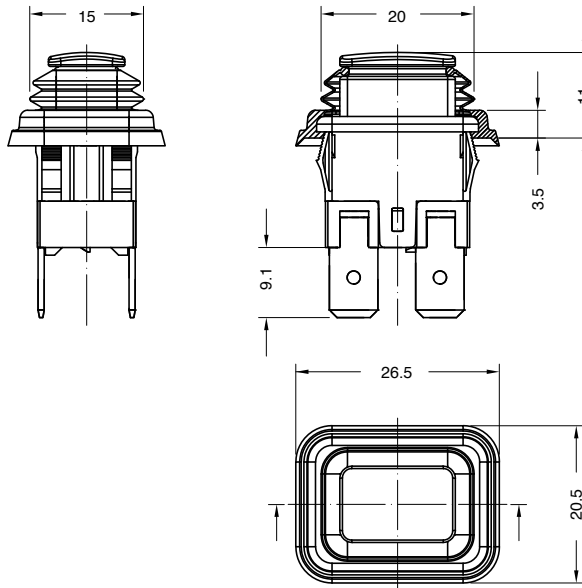

?

TERMINAL

1 Terminal 6.3x0.8

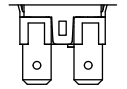

2 Terminal 4.8x0.8

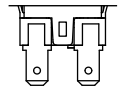

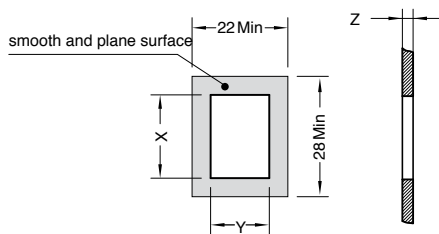

Z	Y	X
0,5 ... 1,2	12,9 $^{+0,1}_0$	19,0 $^{+0,2}_0$
1,2 ... 2,0	12,9 $^{+0,1}_0$	19,3 $^{+0,2}_0$

S	X	L	4	4	TERMINAL	FUNCTION	RATING	RUBBER COLOUR	BUTTON COLOUR	MARKING COLOUR	MARKING	0	0	W

?	?	?	?	?	?	?	0	0	W

FUNCTION RATING RUBBER COLOUR BUTTON COLOUR MARKING COLOUR MARKING

1

2

4

6

7

8

R

H

16 (4) / 250 VAC
 10 (6) / 250 VAC - 5E4
 T125 / 55 °C
 EN 61058

16A - 3/4 HP
 125 / 250 VAC
 T 100 °C
 UL 1054

1 black

2 white

R red

M white

N black

ILLUMINATED

G red

H orange

E green

L white

F blue

X custom

0 none

1 black

2 white

X custom

0

1

R

X



B4MASK



TYPICAL APPLICATIONS	Outdoor electrical equipments, pumps, high pressure cleaners
FUNCTIONS	<ul style="list-style-type: none"> ■ SPST ■ DPST, illuminated or not ■ DPCO
PROTECTION DEGREE	IP 65
CYCLE No.	50.000
CUT OUT	30x22 mm
AMBIENT TEMPERATURE	120 °C
GWT	850 °C
GWT NO FLAME (<2sec)	750 °C on demand

B 4 M A S K

?

DRAWING

TERMINAL

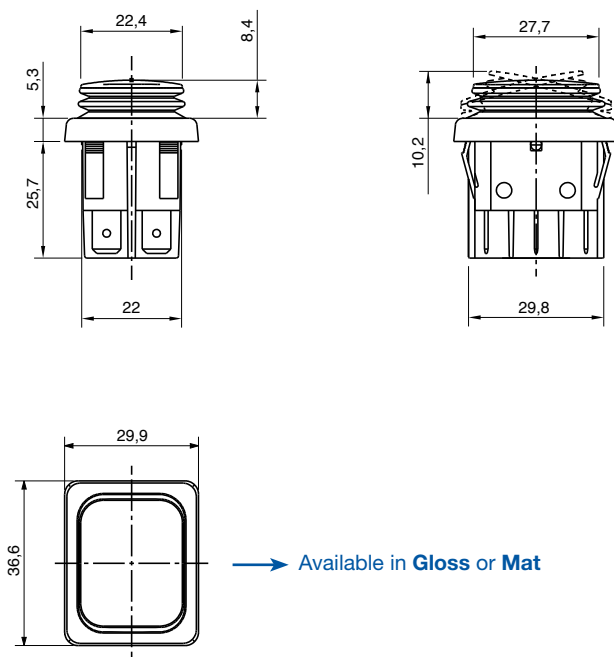

1 Gloss version

3 Mat version

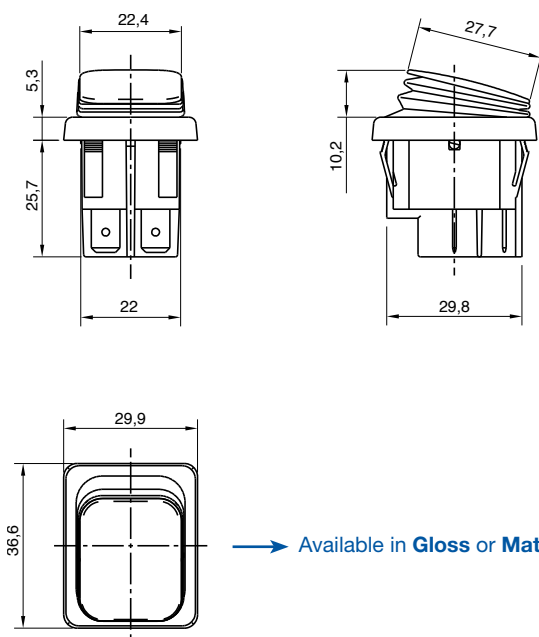
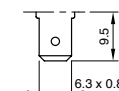

4 Gloss version

5 Mat version

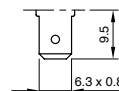

L Gloss version

P Mat version

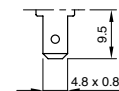

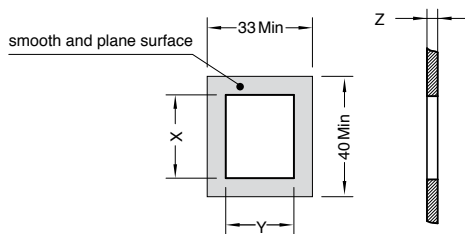

Z	Y	X
0,75 ... 1,25	22,0 $^{+0,2}_0$	30,2 ±0,1
1,25 ... 2,0	22,0 $^{+0,2}_0$	30,6 ±0,1
2,0 ... 3,0	22,0 $^{+0,2}_0$	30,8 ±0,1

B	4	M	A	S	K	TERMINAL	FUNCTION	RATING	RUBBER COLOUR	ROCKER COLOUR	MARKING COLOUR	MARKING	0	0	0

?	?	?	?	?	?	?	0	0	0
FUNCTION	RATING	RUBBER COLOUR	ROCKER COLOUR	MARKING COLOUR	MARKING				

1

2

8

9 Terminal 1 - 3

C

Function 9

16 (6) A / 250 VAC
10 (4) A / 250 VAC - 5E4
T120/55 °C
EN 61058

20 A / 125 VAC
 16 A / 250 VAC
 1/3 HP - 125 VAC
 3/4 HP - 250 VAC
 T105 °C
 UL 1054
 CSA C22.2

E

Function 1

16 (8) A / 250 VAC
12 (10) A / 250 VAC - 5E4
T120 / 55 °C
EN 61058

20 A / 125 VAC
 16 A / 250 VAC
 1/3 HP - 125 VAC
 3/4 HP - 250 VAC
 T105 °C
 UL 1054
 CSA C22.2

N

Function 2 - 8

16 (8) A / 250 VAC
12 (10) A / 250 VAC - 5E4
T120/55 °C
EN 61058

20 A / 125 VAC
 16 A / 250 VAC
 3/4 HP - 125 / 250 VAC
 T105 °C
 UL 1054
 CSA C22.2

S

Function 2 - 8

20 (10) A / 250 VAC
14 (14) A / 250 VAC - 5E4
T120/55 °C
EN 61058

25 A / 125 VAC
 16 A / 250 VAC
 3/4 HP - 125 / 250 VAC
 T105 °C
 UL 1054
 CSA C22.2

1

black

1

black

2

white

3

orange

ILLUMINATED

G

red

E

green

L

white

F

blue

BRIGHT

A

orange

V

green

X

custom

0

none

1

black

2

white

X

custom

0

1

A

9

X

X



SXA4

TYPICAL APPLICATIONS	High pressure cleaners, ironing steam generators, industrial machines, cutters
FUNCTIONS	■ DPST, illuminated or not
PROTECTION DEGREE	IP 54, IP 55 for version with silicone
CYCLE No.	50.000
CUT OUT	30x22 mm
AMBIENT TEMPERATURE	125 °C
GWT	850 °C
GWT NO FLAME (<2sec)	750 °C on demand



S X A 4

DRAWING



O-RING

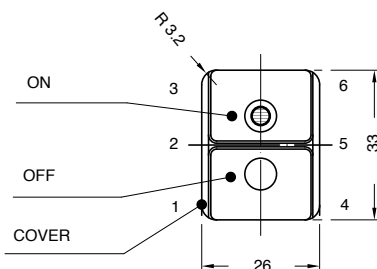
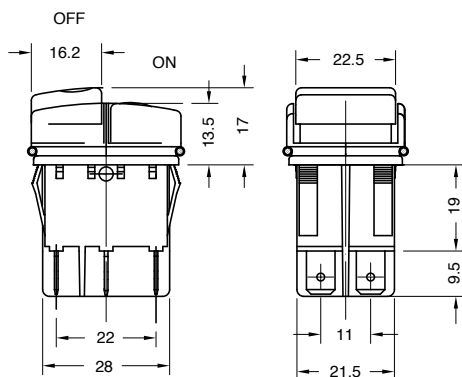

?

TERMINAL

1 Standard

4 With silicone

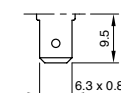

?

FUNCTION

2

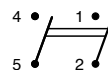

8

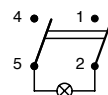

GASKET

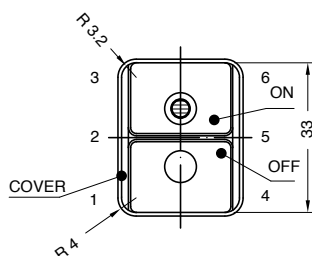
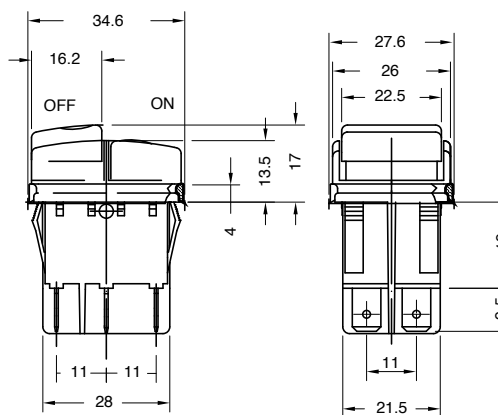

3 Standard

5 With silicone

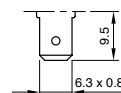

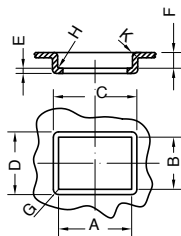
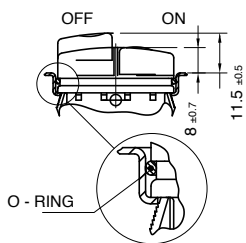

POS.	DIM.	TOL.
K	1.2	±0,1
H	R.0.6	+0.2
G	R.3.5	-0.1
F	5.5	+0.2
E	0.7/3.5	
D	26.6	±0.1
C	33.6	±0.1
B	22	+0.1
A	30	+0.2

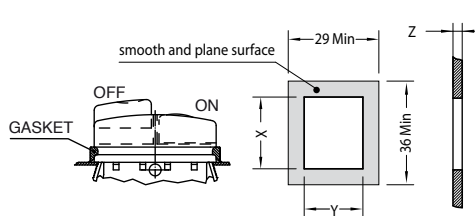

POS.	DIM.	TOL.
Z	0.7/3.5	
Y	22	+0.1
X	30	+0.2

S	X	A	4	TERMINAL	FUNCTION	RATING	FRAME COLOUR	BUTTON COLOUR ON	BUTTON COLOUR OFF	MARKING COLOUR	MARKING ON	MARKING OFF	LENS COLOUR	0	0
---	---	---	---	----------	----------	--------	--------------	------------------	-------------------	----------------	------------	-------------	-------------	---	---

?	?	ON ?	OFF ?	?	ON ?	OFF ?	?	?	0	0
---	---	------	-------	---	------	-------	---	---	---	---

RATING **FRAME COLOUR** **BUTTON COLOUR** **MARKING COLOUR** **MARKING** **LENS COLOUR**

8

Function 2
 16 (8) A / 250 VAC
 10 (6) A / 250 VAC - 5E4
 10 (4) A / 400 VAC
 T125/55 °C
 EN 61058

16 A - 125 / 250 VAC
 3/4 HP - 125 / 250 VAC
 T105 °C
 UL 1054

Function 8
 16 (8) A / 250 VAC
 10 (6) A / 250 VAC - 5E4
 T125/55 °C
 EN 61058

16 A - 125 / 250 VAC
 3/4 HP - 125 / 250 VAC
 T105 °C
 UL 1054

9

Function 2 - 8
 12 (10) A / 250 VAC - 5E4
 T85 °C
 UL 1054

1

black

X

custom

?

1

black

X

custom

?

0

none

2

white

X

custom

?

Marking ON

0



2



3



5



X



Marking OFF

0



1



4



X



0

none

ILLUMINATED

G

red

L

white

X

custom

?



RMASK

TYPICAL APPLICATIONS Steam cleaners, ironing generators

FUNCTIONS

- SPST, illuminated
- DPST, illuminated or not

CYCLE No. 50.000

CUT OUT ø 20 mm

AMBIENT TEMPERATURE 125 °C

GWT 850 °C

GWT NO FLAME (<2sec) 750 °C on demand



R

M

A

S

K

?

DRAWING

1

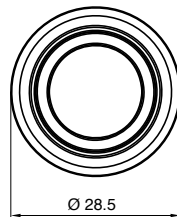
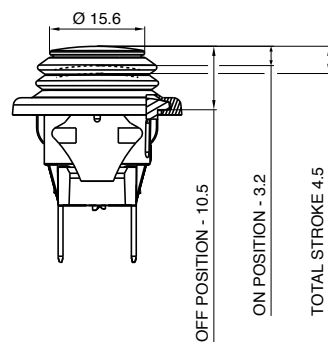
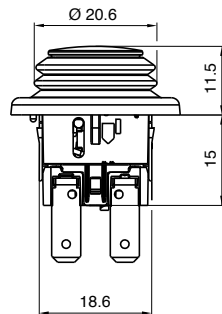

2

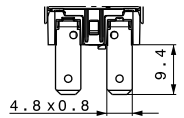

TERMINAL

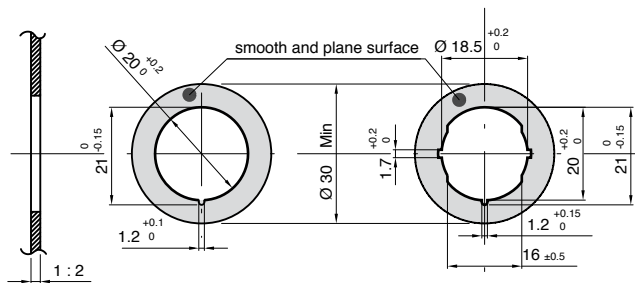

R	M	A	S	K	DRAWING	TERMINAL	FUNCTION	RATING	RUBBER COLOUR	BUTTON COLOUR	0	0	0	0	0
---	---	---	---	---	---------	----------	----------	--------	---------------	---------------	---	---	---	---	---

?

FUNCTION

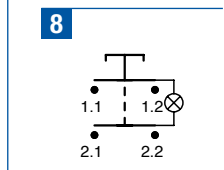
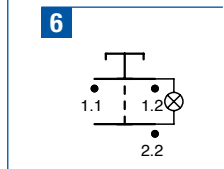
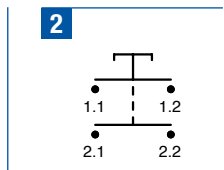

?

RATING

C

16 (6) A / 250 VAC
 12 (10) A / 250 VAC
 8 (8) A / 250 VAC - 5E4
 T125 / 55 °C
 EN 61058

16 A - 125 / 250 VAC
 1 / 2 HP - 125 VAC
 3 / 4 HP - 250 VAC
 T65 °C (T100 °C on demand)
 UL 1054

?

RUBBER COLOUR

1 
 black

?

BUTTON COLOUR

N 
 black

M 
 white

ILLUMINATED 

E 
 green

F 
 blue

G 
 red

H 
 orange

X 
 custom

0 0 0 0 0



SXLR

TYPICAL APPLICATIONS	Steam cleaners
FUNCTIONS	<ul style="list-style-type: none"> ■ SPST, illuminated ■ DPST, illuminated or not
CYCLE No.	50.000
CUT OUT	ø 25 mm
AMBIENT TEMPERATURE	125 °C
GWT	850 °C
GWT NO FLAME (<2sec)	750 °C on demand



S

X

L

R

?

DRAWING

TERMINAL

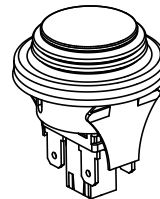
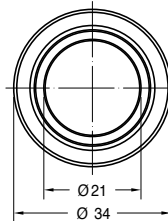
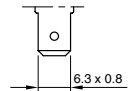
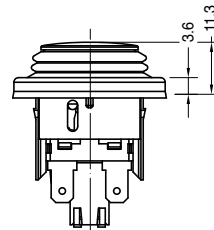
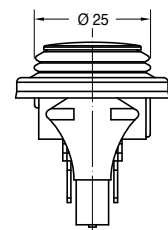

2

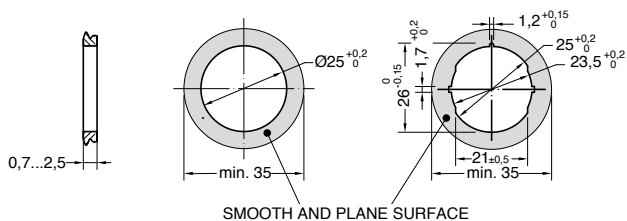

S	X	L	R	TERMINAL	FUNCTION	RATING	RUBBER COLOUR	BUTTON COLOUR	MARKING COLOUR	MARKING	0	0	0
---	---	---	---	----------	----------	--------	---------------	---------------	----------------	---------	---	---	---

?	?	?	?	?	?	?	?	?	?	?	0	0	0
---	---	---	---	---	---	---	---	---	---	---	---	---	---

FUNCTION RATING RUBBER COLOUR BUTTON COLOUR MARKING COLOUR MARKING

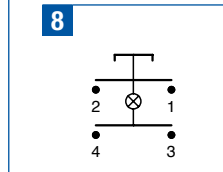
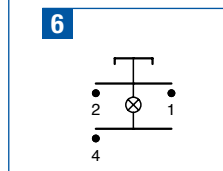
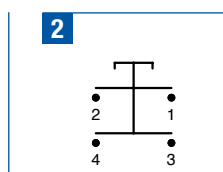

C
16 (4) A / 250 VAC
10 (2) A / 250 VAC - 5E4
T125 °C
EN 61058
 12 A - 125 / 250 VAC
 1/4 HP - 125 VAC
 1/2 HP - 250 VAC
 T100 °C
 UL 1054
 IP65

- 1** black
- 2** white
- X** custom

- M** white
- N** black

ILLUMINATED

- G** red
- H** orange
- E** green
- L** white
- F** blue

- X** custom

- 0** none
- 1** black
- 2** white
- X** custom

- 0**
- D**
- P**
- R**
- X**

Hairdryer Switches

01



CO

112



CN

116



CP

120



CB

122



CK

124



CS

126



DC

128



SUB-ASSEMBLIES

130



CO

TYPICAL APPLICATIONS	Hairdryers
FUNCTIONS	■ SPDT (3 positions 0/1/1+2)
CYCLE No.	50.000
CUT OUT	See drawing
AMBIENT TEMPERATURE	85 °C
GWT	850 °C



C O

DRAWING

?

TERMINAL

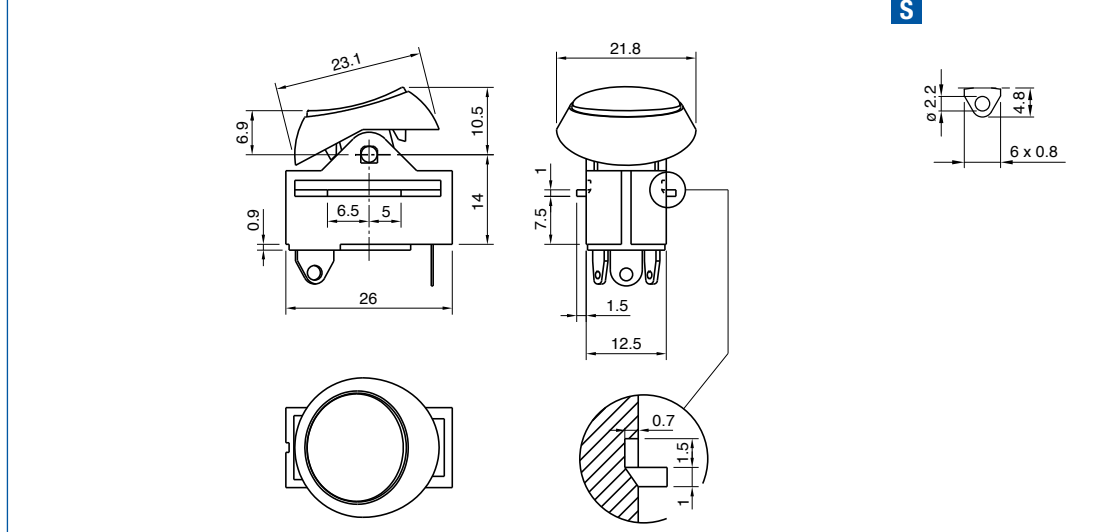
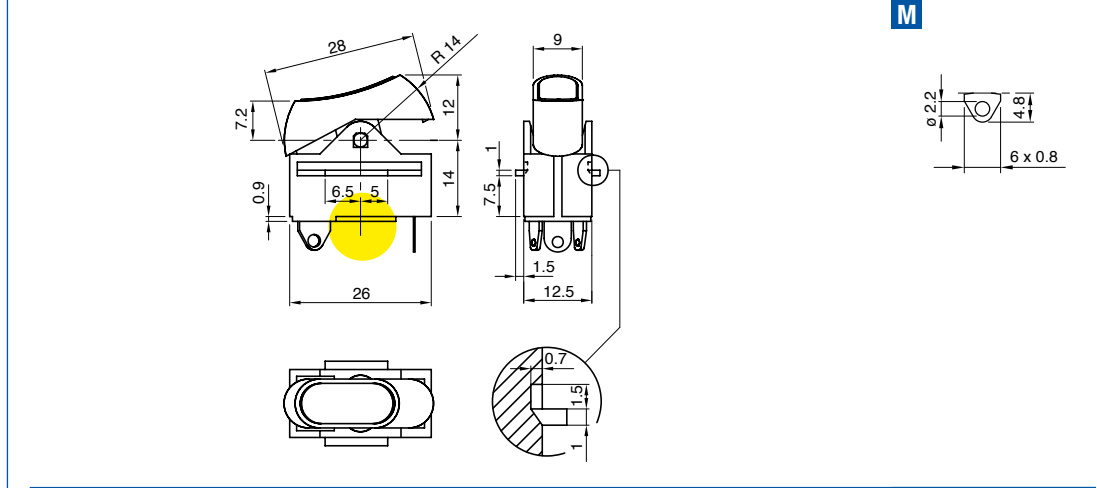
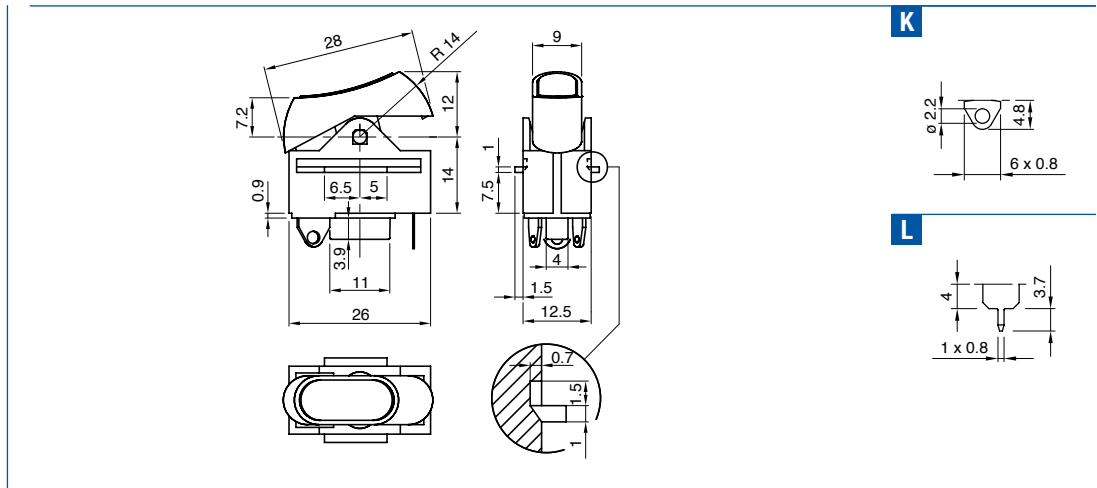

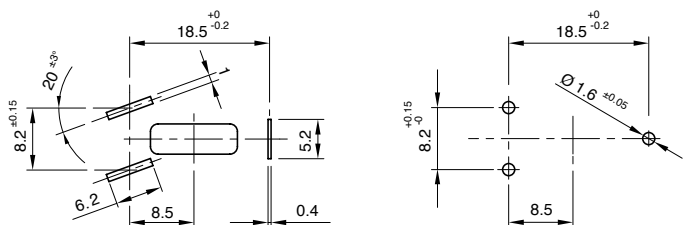

TERMINAL	FUNCTION	RATING	BODY COLOUR	ROCKER COLOUR	MARKING	MARKING COLOUR
C	0					
						0 0

?	?	?	?	?	?	?	0	0
---	---	---	---	---	---	---	---	---

FUNCTION RATING BODY COLOUR ROCKER COLOUR MARKING MARKING COLOUR

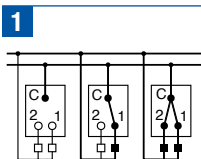

2
 16 A / 250 VAC
 10 A / 250 VAC - 5E4
 T85 °C
 µ disconnection
 EN 61058

3
 16 A / 250 VAC
 10 A / 250 VAC - 5E4
 T85 °C
 µ disconnection
 EN 61058
 13 A / 125 VAC
 6.5 A / 250 VAC
 T65 °C
 UL 1054

1
 brown

- 1** black
- 2** white
- 5** grey
- 9** red
- X** **?** custom

- Terminal S**
- 1** black
 - X** **?** custom

- 0**
- A**
- B**
- C**
- D**
- E**
- F**
- X** **?**

- Terminal S**
- 0**
 - X** **?**

- 0** none
- 1** black
- 2** white
- 5** grey
- 7** light blue
- 8** red
- X** **?** custom



CO

TYPICAL APPLICATIONS	Hairdryers
FUNCTIONS	■ SPDT (3 positions 0/1/1+2)
CYCLE No.	50.000
CUT OUT	See drawing
AMBIENT TEMPERATURE	85 °C
GWT	850 °C



C O

DRAWING

?

TERMINAL

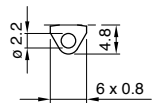
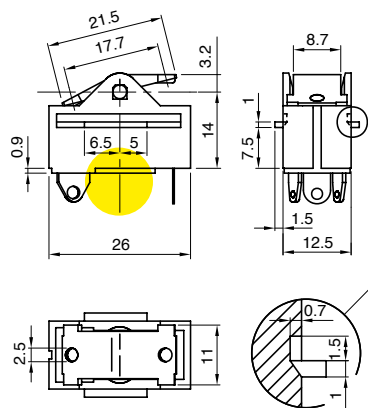
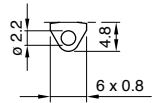
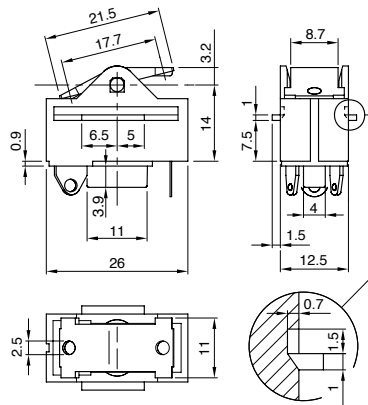

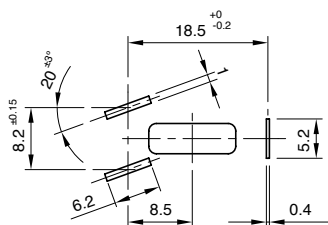

TERMINAL	FUNCTION	RATING	BODY COLOUR	ROCKER COLOUR
C	0			

?	?	?	?
---	---	---	---

0	0	0	0
---	---	---	---

FUNCTION **RATING** **BODY COLOUR** **ROCKER COLOUR**

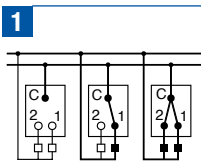

2

16 A / 250 VAC
 10 A / 250 VAC - 5E4
 T85 °C
 µ disconnection
 EN 61058

3

16 A / 250 VAC
 10 A / 250 VAC - 5E4
 T85 °C
 µ disconnection
 EN 61058

13 A / 125 VAC
 6.5 A / 250 VAC
 T65 °C
 UL 1054

1 ■
brown

1 ■
brown



CN

TYPICAL APPLICATIONS	Hairdryers
FUNCTIONS	■ SPDT (3 positions 0/1/1+2)
CYCLE No.	50.000
CUT OUT	See drawing
AMBIENT TEMPERATURE	85 °C
GWT	850 °C



C N

DRAWING

?

TERMINAL

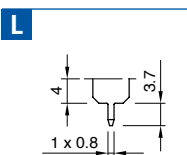
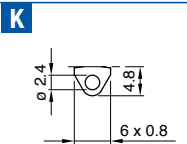
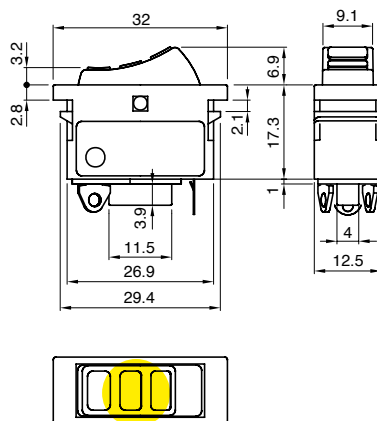
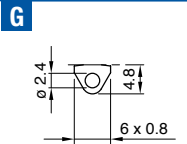
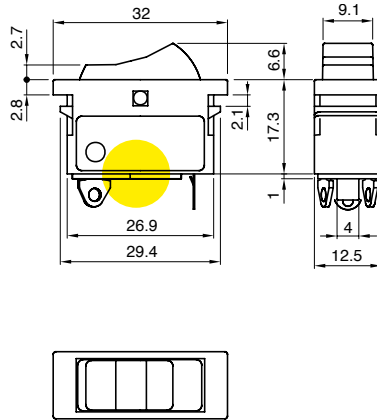
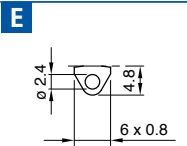
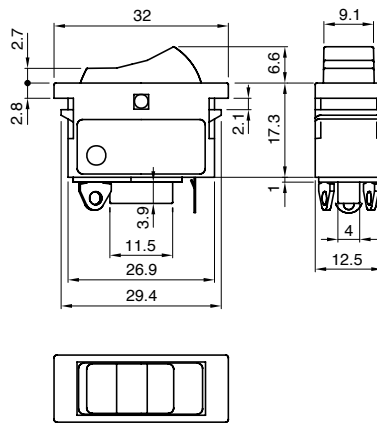

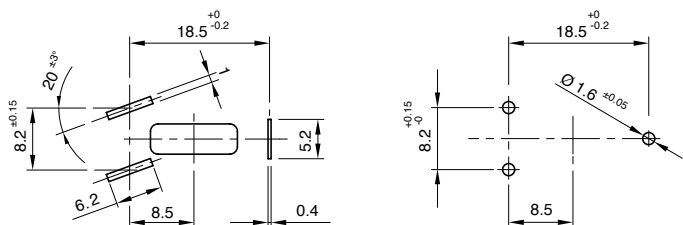

TERMINAL	FUNCTION	RATING	BODY COLOUR	ROCKER COLOUR	MARKING	MARKING COLOUR
C	N					
					0	0

?	?	?	?	?	?	?	0	0
---	---	---	---	---	---	---	---	---

FUNCTION RATING BODY COLOUR ROCKER COLOUR MARKING MARKING COLOUR

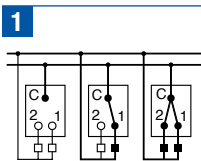

2
 16 A / 250 VAC
 10 A / 250 VAC - 5E4
 T85 °C
 µ disconnection
 EN 61058

3
 16 A / 250 VAC
 10 A / 250 VAC - 5E4
 T85 °C
 µ disconnection
 EN 61058
 13 A / 125 VAC
 6.5 A / 250 VAC
 T65 °C
 UL 1054

1 █
 black

X ?
 custom

1 █
 black

2 █
 white

9 █
 red

X ?
 custom

0 None

Terminal E - G

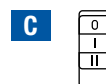
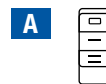

Terminal K - L

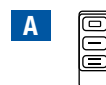

X ?
 custom

0 none

1 █
 black

2 █
 white

5 █
 grey

7 █
 light blue

8 █
 red

X ?
 custom



CN

TYPICAL APPLICATIONS	Hairdryers
FUNCTIONS	■ SPDT (3 positions 0/1/1+2)
CYCLE No.	50.000
CUT OUT	See drawing
AMBIENT TEMPERATURE	85 °C
GWT	850 °C



C **N**

DRAWING

?

TERMINAL

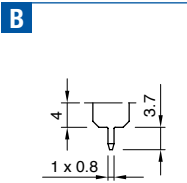
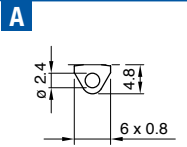
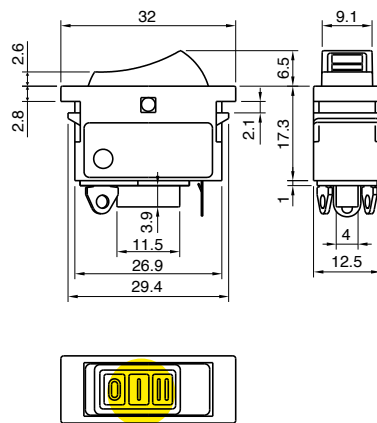
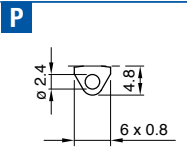
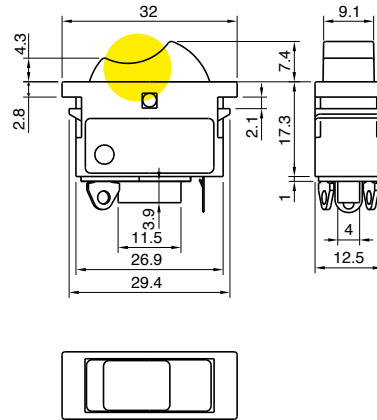

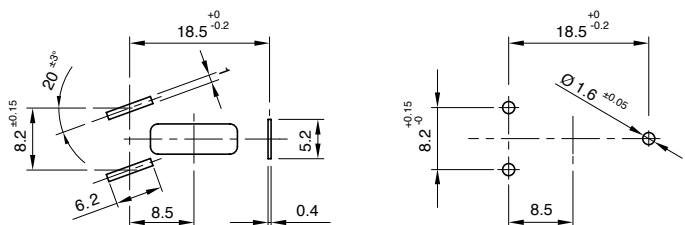

TERMINAL	FUNCTION	RATING	BODY COLOUR	ROCKER COLOUR	MARKING	MARKING COLOUR
C	N					
0	0					

?	?	?	?	?	?	?
FUNCTION	RATING	BODY COLOUR	ROCKER COLOUR	MARKING	MARKING COLOUR	

0 0

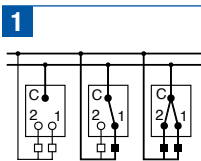

2

16 A / 250 VAC
10 A / 250 VAC - 5E4
T85 °C
µ disconnection
EN 61058

3

16 A / 250 VAC
10 A / 250 VAC - 5E4
T85 °C
µ disconnection
EN 61058

13 A / 125 VAC
6.5 A / 250 VAC
T65 °C
UL 1054

1 ■
black

X ?
custom

1 ■
black

2 ■
white

9 ■
red

X ?
custom

Terminal P

0

C

D

X ?

0
none

1 ■
black

2 ■
white

5 ■
grey

7 ■
light blue

8 ■
red

X ?
custom

Terminal A - B

0

Terminal A - B

0
none



CP

TYPICAL APPLICATIONS	Hairdryers
FUNCTIONS	■ SPDT (3 positions 0/1/1+2)
CYCLE No.	50.000
CUT OUT	See drawing
AMBIENT TEMPERATURE	85 °C
GWT	850 °C



TERMINAL

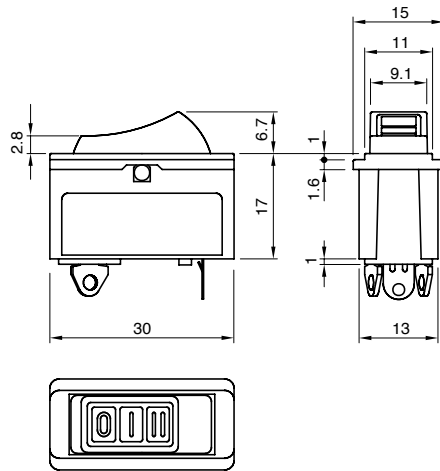

C

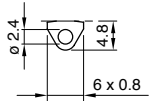

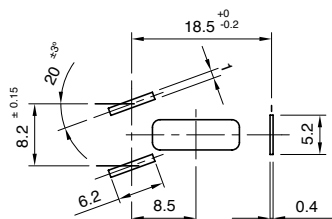

TERMINAL	FUNCTION	RATING	BODY COLOUR	ROCKER COLOUR				
C	P				0	0	0	0

?	?	?	?
FUNCTION	RATING	BODY COLOUR	ROCKER COLOUR

0	0	0	0
---	---	---	---

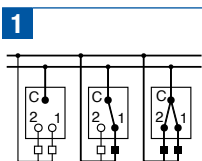

2

16 A / 250 VAC
 10 A / 250 VAC - 5E4
 T85 °C
 μ disconnection
 EN 61058

3

16 A / 250 VAC
 10 A / 250 VAC - 5E4
 T85 °C
 μ disconnection
 EN 61058

13 A / 125 VAC
 6.5 A / 250 VAC
 T65 °C
 UL 1054

1

black

2

white

X

custom

1

black

2

white

9

red

X

custom



CB

TYPICAL APPLICATIONS	Hairdryers
FUNCTIONS	■ 2x SPST (3 positions 0-0/0-1/1-1)
CYCLE No.	50.000
CUT OUT	See drawing
AMBIENT TEMPERATURE	85 °C
GWT	850 °C



C B

DRAWING

?

TERMINAL

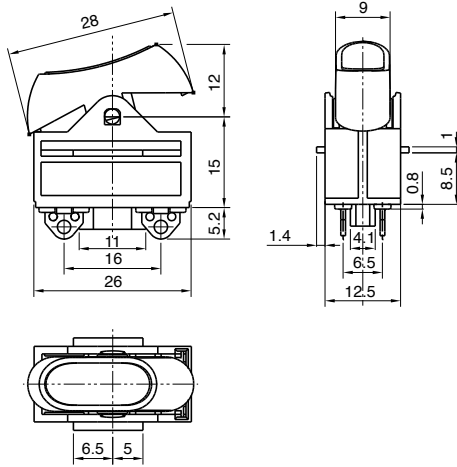

K

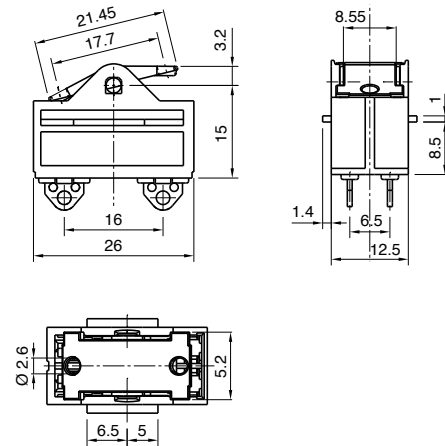
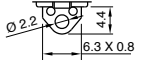

G

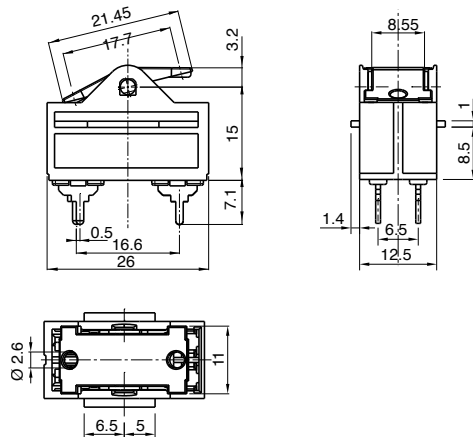
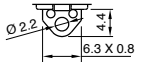

H

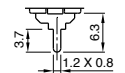

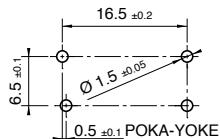
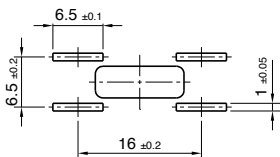

	TERMINAL	FUNCTION	RATING	BODY COLOUR	ROCKER COLOUR	MARKING	MARKING COLOUR		
C	B							0	0

?	?	?	?	?	?	?	?	0	0
FUNCTION	RATING	BODY COLOUR	ROCKER COLOUR	MARKING	MARKING COLOUR				

1

2

16 A / 250 VAC
10 A / 250 VAC - 5E4
T85 °C
µ disconnection
EN 61058

16 A / 125 VAC
T105 °C
UL 1054

1
brown

- Terminal K
- 0** none
 - 1** black
 - 5** grey
 - 9** red
 - X** ? custom

Terminal G - H

1
brown

- Terminal K
- 0**
 - A**
 - D**
 - E**
 - X** ?

Terminal G - H

0 None

- Terminal K
- 0** none
 - 1** black
 - 2** white
 - 7** light blue
 - 8** red
 - X** ? custom

Terminal G - H

0 None



CK

TYPICAL APPLICATIONS	Hairdryers
FUNCTIONS	■ 2x SPST (3 positions 0-0/0-1/1-1)
CYCLE No.	50.000
CUT OUT	See drawing
AMBIENT TEMPERATURE	85 °C
GWT	850 °C



C

K

DRAWING

?

TERMINAL

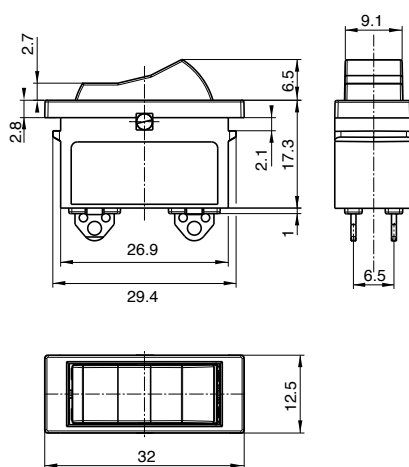

G

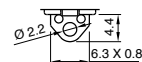

H

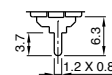

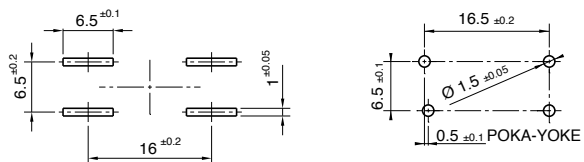

C	K	TERMINAL	FUNCTION	RATING	BODY COLOUR	BUTTON COLOUR	MARKING	MARKING COLOUR	0	0

?	?	?	?	?	?	?	0	0
---	---	---	---	---	---	---	---	---

FUNCTION **RATING** **BODY COLOUR** **ROCKER COLOUR** **MARKING** **MARKING COLOUR**

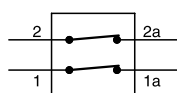
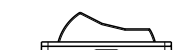
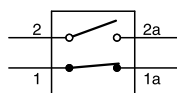
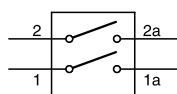

2

16 A / 250 VAC
 10 A / 250 VAC - 5E4
 T85/55 °C
 µ disconnection
 EN 61058

16 A / 125 VAC
 T65 °C
 UL 1054

1 ■
 black

1 ■
 black

9 ■
 red

0

A

B

X

0
 none

2 □
 white

X ?
 custom



CS

TYPICAL APPLICATIONS Hairdryers

FUNCTIONS ■ 2x SPST (3 positions 0-0/0-1/1-1)

CYCLE No. 50.000

CUT OUT See drawing

AMBIENT TEMPERATURE 85 °C

GWT 850 °C



C

S

DRAWING

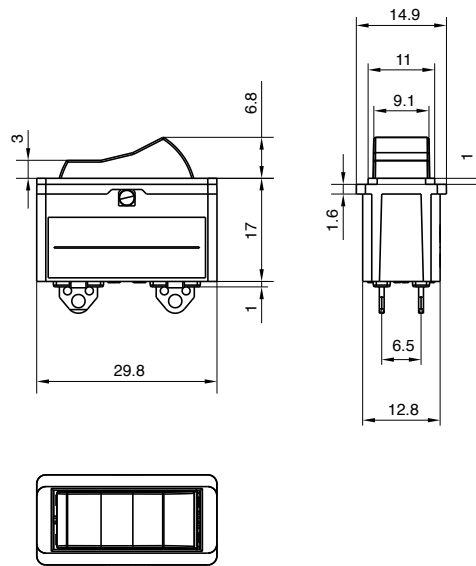

?

TERMINAL

G

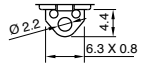

H

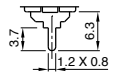

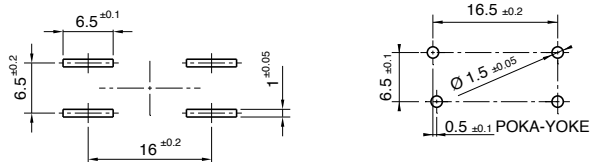

C	S	TERMINAL	FUNCTION	RATING	BODY COLOUR	BUTTON COLOUR	MARKING	MARKING COLOUR	0	0

?	?	?	?	?	?	?	?	0	0
---	---	---	---	---	---	---	---	---	---

FUNCTION **RATING** **BODY COLOUR** **ROCKER COLOUR** **MARKING** **MARKING COLOUR**

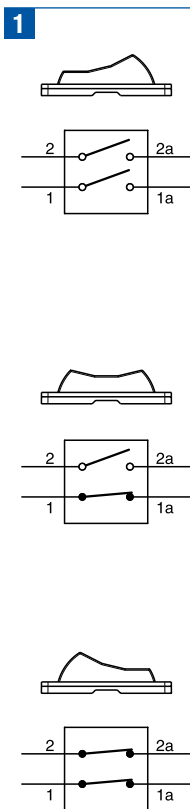

2

16 A / 250 VAC
 10 A / 250 VAC - 5E4
 T85/55 °C
 µ disconnection
 EN 61058

16 A / 125 VAC
 T65 °C
 UL 1054

1 ■
 black

1 ■
 black

- 0**
- A**
- B**
- X**

- 0** none
- 2** white
- X** custom



DC

TYPICAL APPLICATIONS	Hairdryers
FUNCTIONS	■ SPST, momentary or not
CYCLE No.	50.000
CUT OUT	-
AMBIENT TEMPERATURE	125 °C
GWT	850 °C



TERMINAL

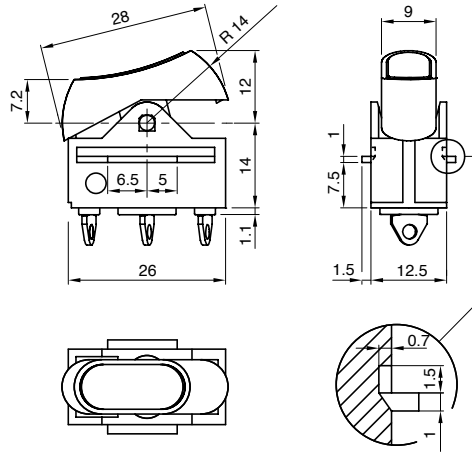

S

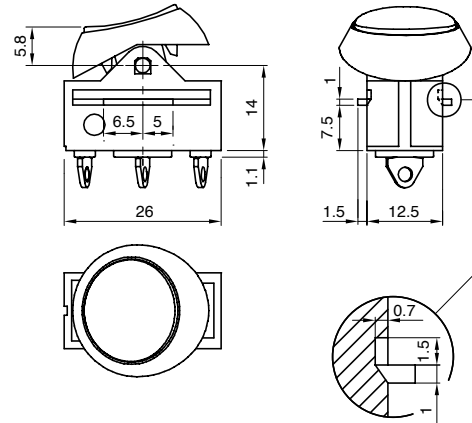
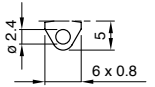

U

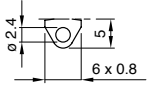

TERMINAL	FUNCTION	RATING	BODY COLOUR	ROCKER COLOUR	MARKING COLOUR	MARKING
D	C					
						0 0 0 0

FUNCTION	RATING	BODY COLOUR	ROCKER COLOUR	MARKING COLOUR	MARKING
?	?	?	?	?	? 0 0 0 0

1	
4	
A	

C
 16 A - 6 (6) A / 250 VAC
 10 A - 4 (4) A / 250 VAC - 5E4
 T125 °C
 EN 61058

16 A / 125 VAC
 8 A / 250 VAC
 T65 °C
 UL 1054
 CSA C22.2

1
 black

1
 black

2
 white

9
 red

B
 blue

X
 custom

0
 none

1
 black

2
 white

X
 custom

Terminal S	
0	
C	
R	
X	
Terminal U	
0	
A	
X	

SUB-ASSEMBLIES

In order to increase the collaboration with its own customers to create added value solutions, Everel has developed internal competencies and technologies to design and to manufacture control boards.

This type of activity has been particularly effective in combination with electromechanical components design and production, field in which Everel is a recognized leader; it has found very appreciated applications in control boards of hairdryers.

In close partnership with its own customers, Everel has developed many products. The R&D staff is available to design the perfect solutions according with Customer requests.

Below you could find some example of Everel sub-assemblies:

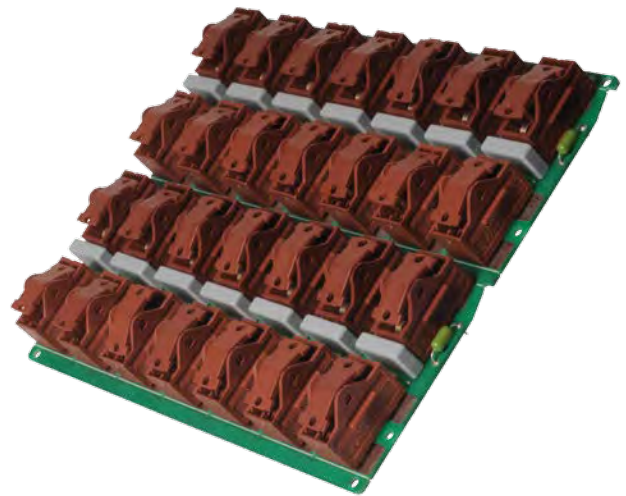

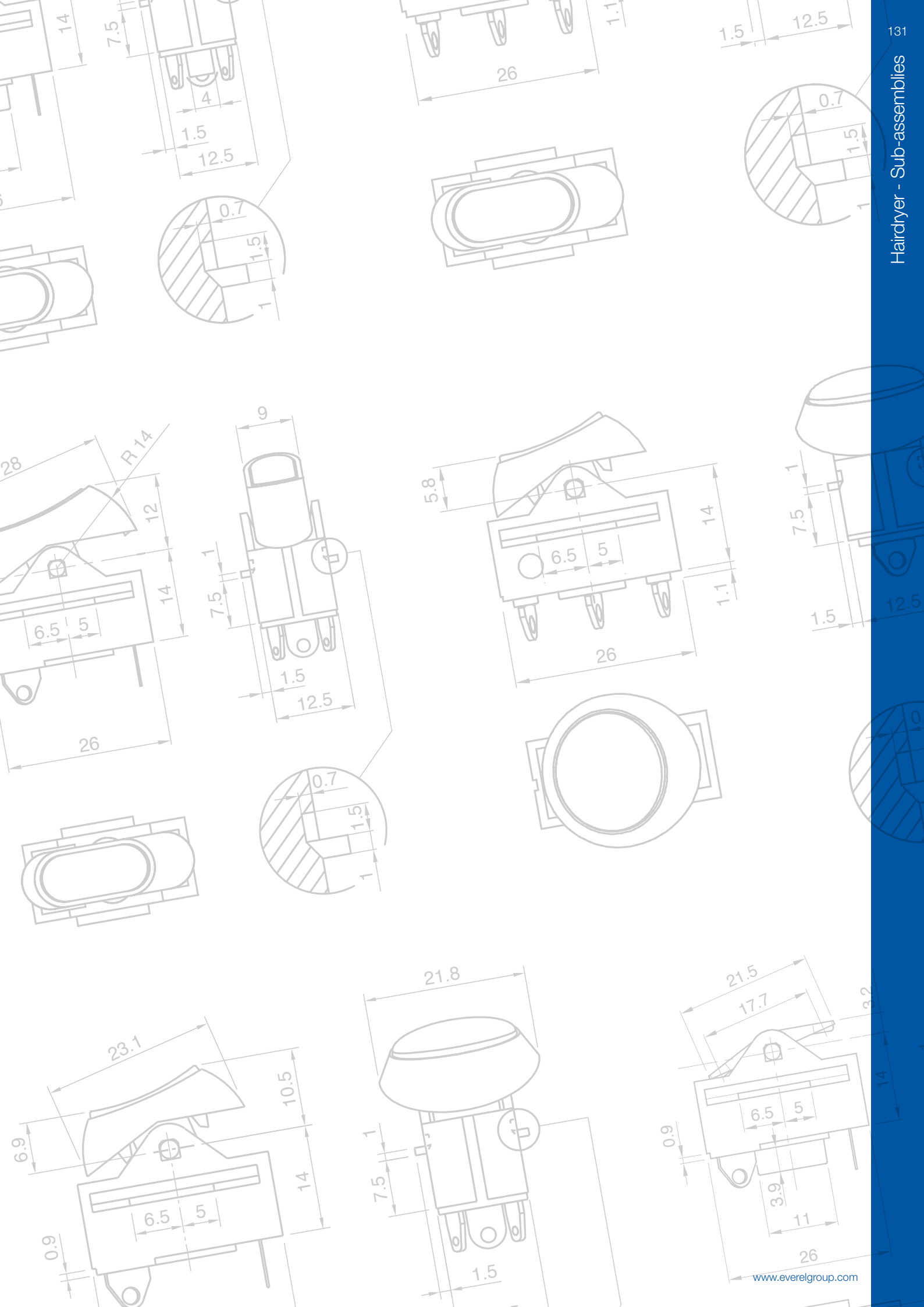

Slide and Rotary Switches

01



LF

134



P5

136



R1

138



DS

140



DH

141



LF

TYPICAL APPLICATIONS Cooker hoods, hairdryers

FUNCTIONS

- 1 step, SP or DP
- 2 steps, DP
- 3 steps, DP

CYCLE No. 10.000

CUT OUT Rear panel

AMBIENT TEMPERATURE 125 °C

GWT 850 °C

GWT NO FLAME (<2sec) 750 °C



L

F

?

DRAWING



LF2



LF3



LF4

2

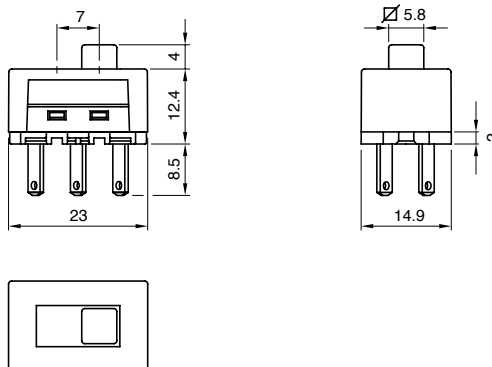

3

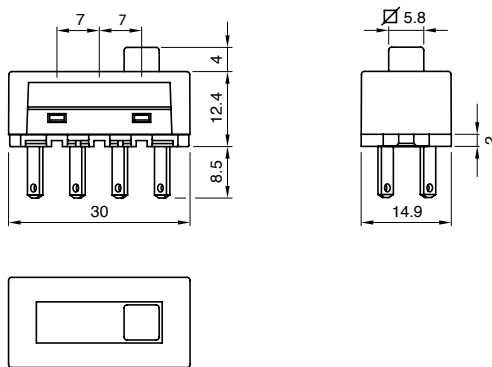

4

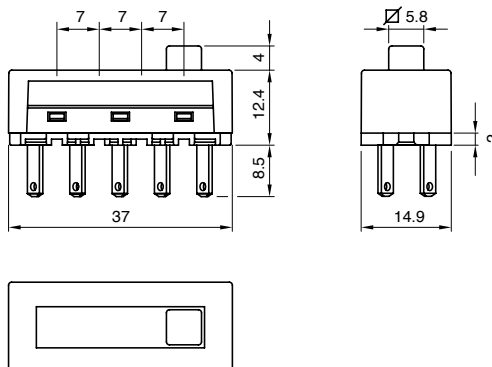

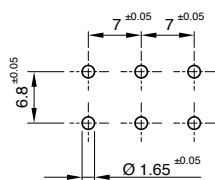

LF2

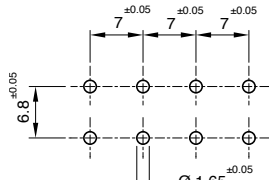

LF3

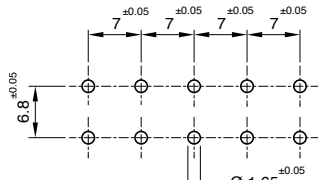

LF4

DRAWING	TERMINAL	FUNCTION	RATING				
L	F			0	0	0	W

?

TERMINAL

?

FUNCTION

?

RATING

0

0

0

W

1

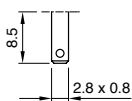

2

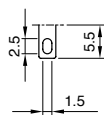

4

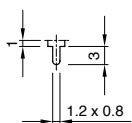

Drawing 2

A

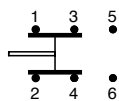

B

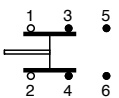

E

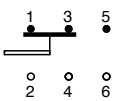

3

8 (3) A / 250 VAC
T125 °C
EN 61058

8 A / 125 VAC
T65 °C
UL 1054

Drawing 3

A

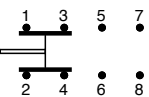

B

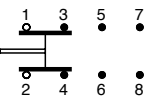

Drawing 4

A

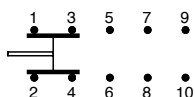

B

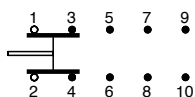



P5

TYPICAL APPLICATIONS Cooker hoods, hairdryers

FUNCTIONS ■ 5 steps, DP

CYCLE No. 10.000

CUT OUT Rear panel

AMBIENT TEMPERATURE 125 °C

GWT 850 °C

GWT NO FLAME (<2sec) 750 °C on demand



P

5

DRAWING

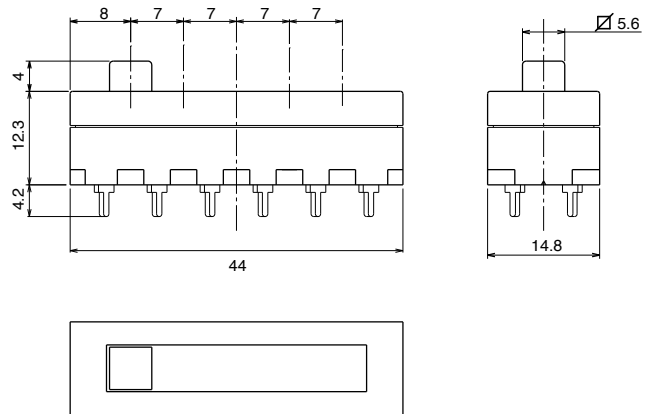

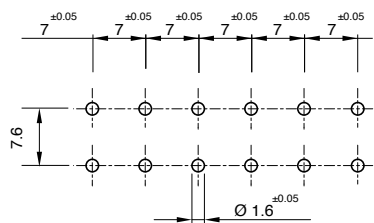

	RATING	FUNCTION	TERMINAL			
P	5			0	0	0

?

RATING

?

FUNCTION

?

TERMINAL

0

0

0

L

10 A / 250 VAC
5 (5) A / 250 VAC
T125/55 °C
EN 61058

13 A / 125 VAC
6.5 A / 250 VAC
T65 °C
UL 1054

A

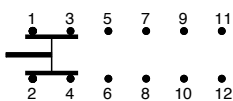

B

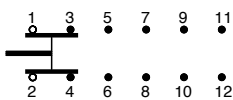

C

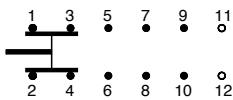

0

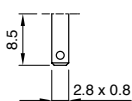

4

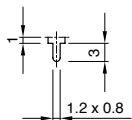



R1

TYPICAL APPLICATIONS	Fan heaters, small ovens, cleaners
FUNCTIONS	■ 30° steps (up to 6 positions), SP or DP
CYCLE No.	10.000 (50.000 on demand)
CUT OUT	28 mm interaxes screws
AMBIENT TEMPERATURE	150 °C
GWT	850 °C
GWT NO FLAME (<2sec)	750 °C on demand



R 1

DRAWING

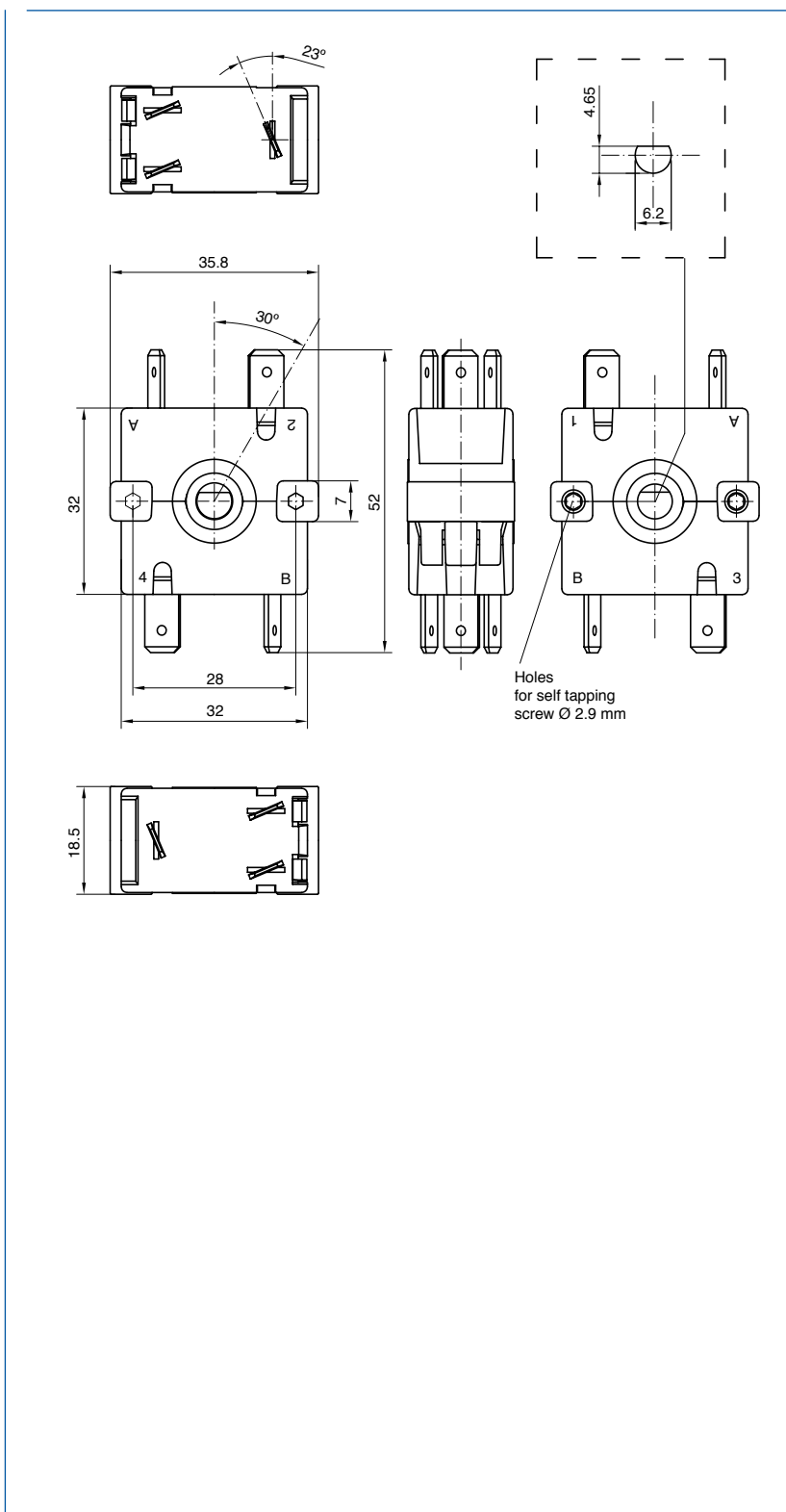

?

TERMINAL

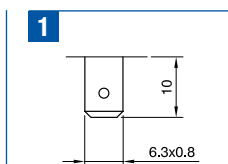

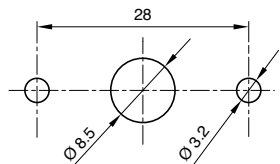

TERMINAL	FUNCTION	RATING	SHAFT
R	1		
			0 0

? ?

FUNCTION

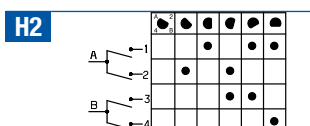
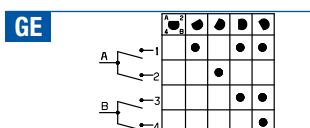
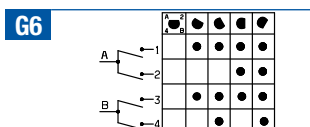
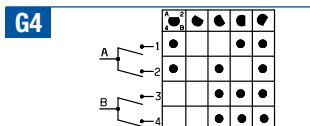
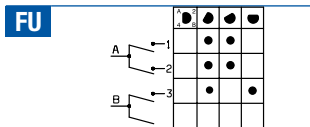
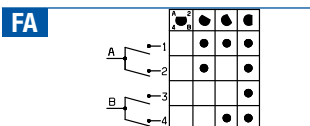
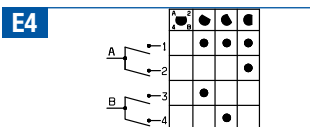
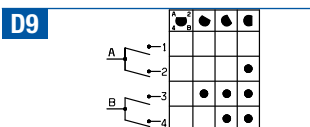
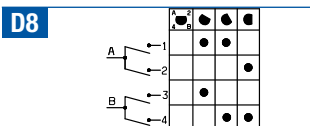
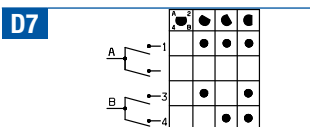
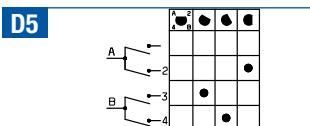
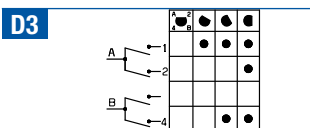
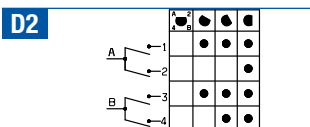
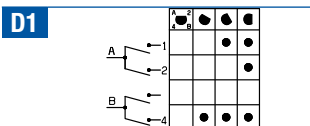
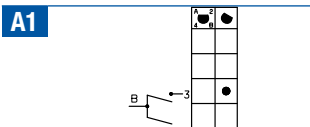

?

RATING

1
 13 (3) A / 250 VAC
 6 (6) A / 250 VAC
 T150 °C
 EN 61058

13 A / 125 VAC
 T65 °C
 UL 1054

?

SHAFT

0 No shaft

1

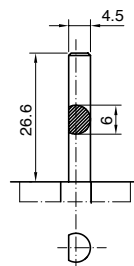

Shaft also available separately R019000

2

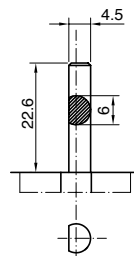

Shaft also available separately R023000

3

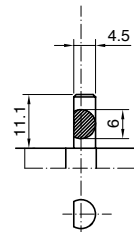

Shaft also available separately R022000

4

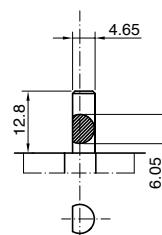

Shaft also available separately R104000



DS

TYPICAL APPLICATIONS	HVAC
FUNCTIONS	■ 45° steps (with 3 or 5 rest positions), SP
CYCLE No.	50.000
CUT OUT	Rear panel
AMBIENT TEMPERATURE	85 °C
GWT	850 °C
GWT NO FLAME (<2sec)	750 °C on demand



DRAWING

DS37

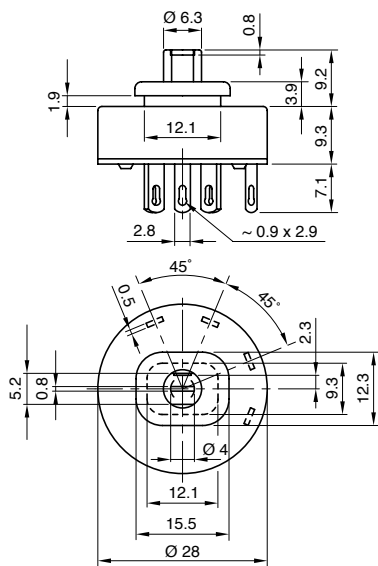

FUNCTION

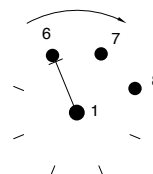

RATING

2 (2) A / 250 VAC - 5E4
T85 °C
EN 61058
 2A / 250 VAC
 T65 °C
 UL 1054

DS51

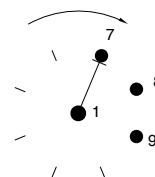
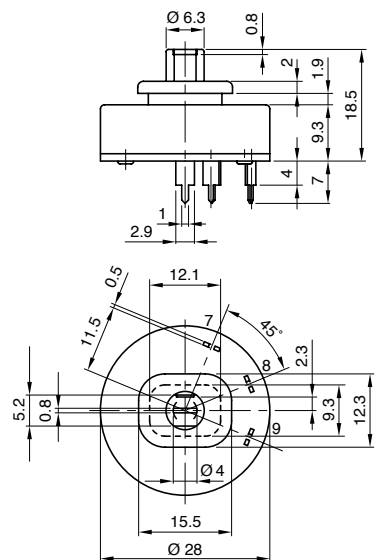



DH

TYPICAL APPLICATIONS	Circulation pumps
FUNCTIONS	■ 45° steps (with 3 positions), SP
CYCLE No.	10.000
CUT OUT	Rear panel
AMBIENT TEMPERATURE	85 °C
GWT	850 °C
GWT NO FLAME (<2sec)	750 °C



DRAWING

DH3

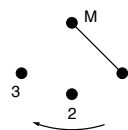
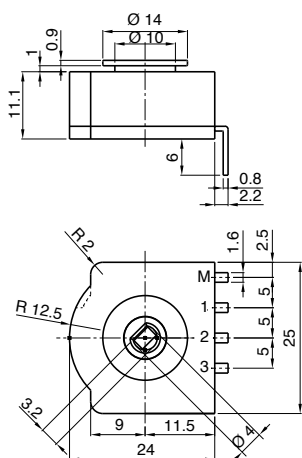

RATING

2 (2) A / 250 VAC
1 (0.5) A / 250 VAC
T85 °C
EN 61058

2A / 125 VAC
 T85 °C
 UL 1054

DH4

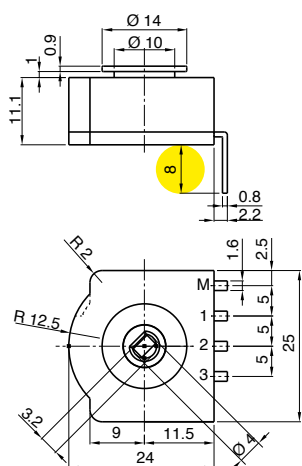

Micro Switches

01



MSA

144



MSS

146



MSA



OPERATING SPEED	0,1 - 1 m/s (related to actuator form)
OPERATING FREQUENCY	Mechanical 60 cycles/min; Electrical 15 cycle/min
INSULATION RESISTANCE	≥100MΩ (500 VDC)
CONTACT RESISTANCE	< 100mΩ (initial value)
TEST VOLTAGE (each terminal same polarity)	AC1000V, 50/60HZ, 1MIN
TEST VOLTAGE (each terminal and non current carrying metal parts)	AC1500V, 50/60HZ, 1MIN
TEMPERATURE GRADE	-25 °C ≤ T ≤ 125 °C
VIBRATION RESISTANCE	10-55Hz, 1.5mm, double amplitude
LIFE EXPECTANCY	Mechanical ≥ 10 Mio cycles Electrical ≥ 50 k cycles

DRAWING

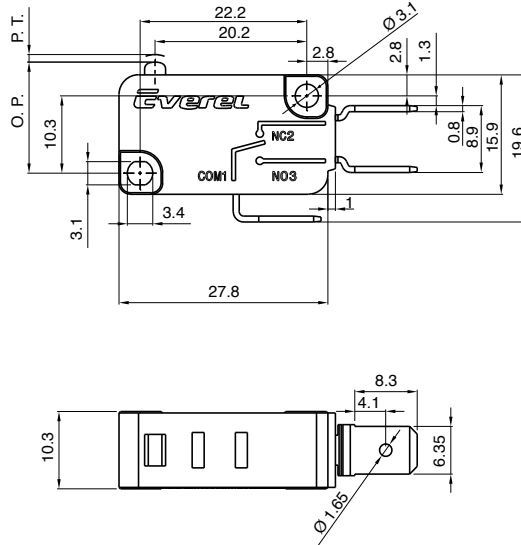
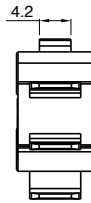

TEMPERATURE GRADE

ELECTRICAL RATING

TERMINAL STYLE

CIRCUIT CODE

OPERATING FORCE

T
25T125

16
16 (4) A / 250 VAC - 5E4
μ disconnection
EN 61058

16 A - 120/250 VAC
1/2 HP - 120/250 VAC
UL 1054

26
26 (10) A / 250 VAC - 5E4
μ disconnection
EN 61058

C1
6.3 X 0.8

Z SPDT

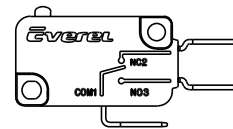

P SPST NO

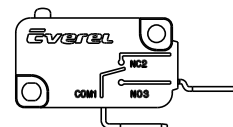

C SPST NC

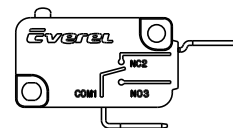

200
Electrical Rating 16
200 gf 1,96N

300
Electrical Rating 26
300 gf 2,94N

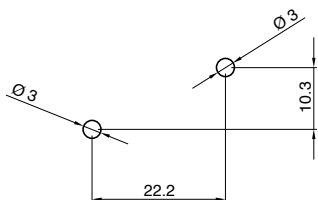

TEMP. GRADE		ELECTRICAL RATING		TERMINAL STYLE		CIRCUIT CODE		OPERATING FORCE			LEVER TYPE		
M	S	A									0	0	0

ACCESSORIES: LEVERS AVAILABLE

000

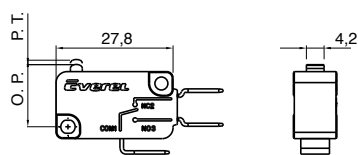

PARAMETERS							
OF Max		RF Min		PT Max	OT Min	DT Max	OP
(N)	(gf)	(N)	(gf)	(mm)	(mm)	(mm)	(mm)
1.96	200	0.49	50	1.6	0.8	0.4	14.7

A01

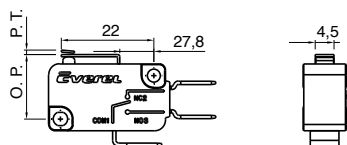

PARAMETERS							
OF Max		RF Min		PT Max	OT Min	DT Max	OP
(N)	(gf)	(N)	(gf)	(mm)	(mm)	(mm)	(mm)
1.96	200	0.49	50	1.6	0.8	0.4	15.3

A02

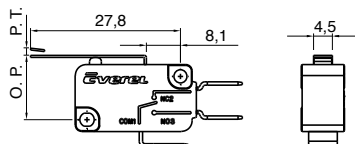

PARAMETERS							
OF Max		RF Min		PT Max	OT Min	DT Max	OP
(N)	(gf)	(N)	(gf)	(mm)	(mm)	(mm)	(mm)
1.18	120	0.20	20	3.2	1.3	1.2	15.3

A04

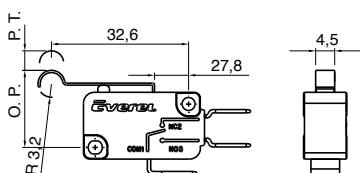

PARAMETERS							
OF Max		RF Min		PT Max	OT Min	DT Max	OP
(N)	(gf)	(N)	(gf)	(mm)	(mm)	(mm)	(mm)
1.18	120	0.20	20	3.2	1.3	1.2	18.3

A05

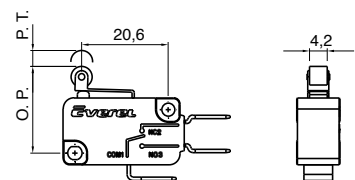

PARAMETERS							
OF Max		RF Min		PT Max	OT Min	DT Max	OP
(N)	(gf)	(N)	(gf)	(mm)	(mm)	(mm)	(mm)
2.35	240	0.39	40	1.6	0.8	0.4	20.6

A06

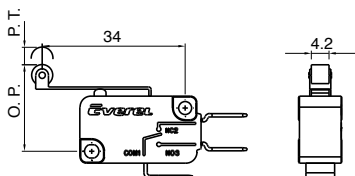

PARAMETERS							
OF Max		RF Min		PT Max	OT Min	DT Max	OP
(N)	(gf)	(N)	(gf)	(mm)	(mm)	(mm)	(mm)
1.18	120	0.20	20	3.2	1.3	1.2	20.6

OF = Operating Force **OT** = Over Travel
RF = Related Force **DT** = Different Travel
PT = Pre Travel **OP** = Operating Position



MSS



OPERATING SPEED	0,1 - 1 m/s (related to actuator form)
OPERATING FREQUENCY	Mechanical 60 cycles/min; Electrical 15 cycle/min
INSULATION RESISTANCE	≥100MΩ (500 VDC)
CONTACT RESISTANCE	< 100mΩ (initial value)
TEST VOLTAGE (each terminal same polarity)	AC1000V, 50/60HZ, 1MIN
TEST VOLTAGE (each terminal and non current carrying metal parts)	AC1500V, 50/60HZ, 1MIN
TEMPERATURE GRADE	-25 °C ≤ T ≤ 125 °C
VIBRATION RESISTANCE	10-55Hz, 1.5mm, double amplitude
LIFE EXPECTANCY	Mechanical ≥ 10 Mio cycles Electrical ≥ 50 k cycles

DRAWING

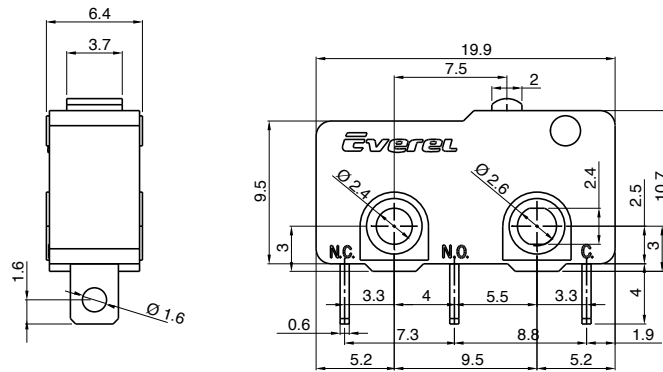

ELECTRICAL RATING

- 05**
5 A - 125/250 VAC - 5E4
25T125
µ disconnection
EN 61058

5 A - 125/250 VAC
1/8 HP - 125/250 VAC
UL 1054
- 12**
12 (6) A - 125/250 VAC
40T125
µ disconnection
EN 61058

12 A - 125/250 VAC
UL 1054

OPERATING FORCE

- 150** Electrical rating 05
150 gf
- 350** Electrical rating 12
350 gf

TERMINAL STYLE

- S**
Solder connect

LEVER TYPE

- 00**
No lever

All levers available in Accessories section

CIRCUIT CODE

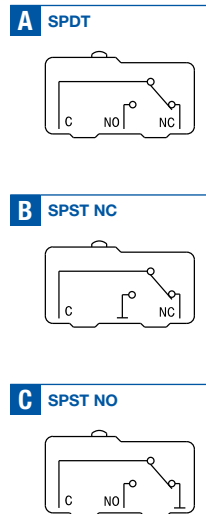

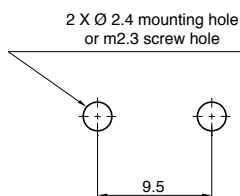

ELECTRICAL RATING		OPERATING FORCE			TERMINAL STYLE	LEVER TYPE		CIRCUIT CODE			
M	S	S							0	0	0

ACCESSORIES: LEVERS AVAILABLE

00

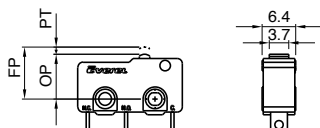

PARAMETERS								
OF Max		RF Min		PT Max	OT Min	DT Max	FP Max	OP
(N)	(gf)	(N)	(gf)	(mm)	(mm)	(mm)	(mm)	(mm)
1.47	150	0.34	35	1.0	0.4	0.2	9.1	8.5

01

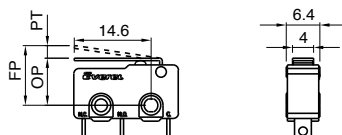

PARAMETERS								
OF Max		RF Min		PT Max	OT Min	DT Max	FP Max	OP
(N)	(gf)	(N)	(gf)	(mm)	(mm)	(mm)	(mm)	(mm)
0.49	50	0.078	8	8	3.6	1.0	11.7	8.9

02

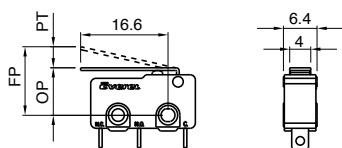

PARAMETERS								
OF Max		RF Min		PT Max	OT Min	DT Max	FP Max	OP
(N)	(gf)	(N)	(gf)	(mm)	(mm)	(mm)	(mm)	(mm)
0.44	45	0.059	6	4.0	0.6	1.0	12.0	8.9

03

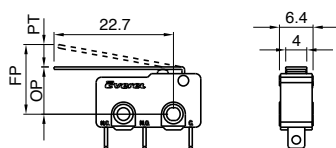

PARAMETERS								
OF Max		RF Min		PT Max	OT Min	DT Max	FP Max	OP
(N)	(gf)	(N)	(gf)	(mm)	(mm)	(mm)	(mm)	(mm)
0.34	35	0.059	6	6.1	0.8	1.8	13.5	8.9

05

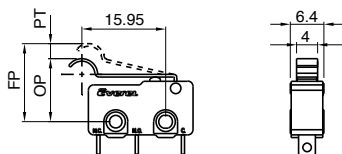

PARAMETERS								
OF Max		RF Min		PT Max	OT Min	DT Max	FP Max	OP
(N)	(gf)	(N)	(gf)	(mm)	(mm)	(mm)	(mm)	(mm)
0.44	45	0.059	6	5.0	0.6	1.0	18.5	12.2

06

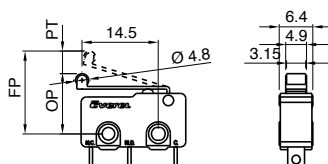

PARAMETERS								
OF Max		RF Min		PT Max	OT Min	DT Max	FP Max	OP
(N)	(gf)	(N)	(gf)	(mm)	(mm)	(mm)	(mm)	(mm)
0.49	50	0.078	8	3.8	0.8	1.0	17.6	14.6

OF = Operating Force
RF = Related Force
PT = Pre Travel
OT = Over Travel
DT = Different Travel
FP = Free Position
OP = Operating Position

Control Boards

02



T5

150



TM4

152



TM5

153



T5



Reported to internal components



T 5

DRAWING

Switch series Touch

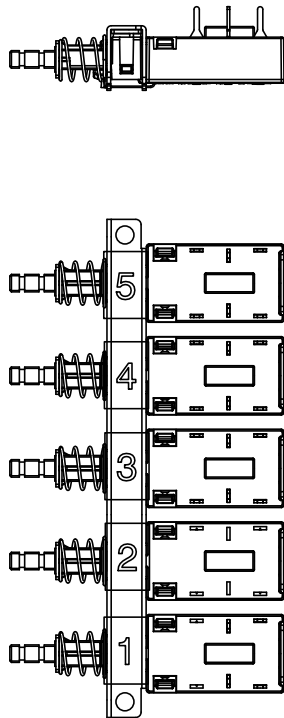

TYPICAL APPLICATIONS	Cooker hoods, coffee machines, microwave ovens
FUNCTIONS	Switch Keyboard <ul style="list-style-type: none"> ■ SPST, momentary or not ■ SPDT, momentary or not ■ DPST, momentary or not ■ DPDT, momentary or not
CYCLE No.	10.000
CUT OUT	-
AMBIENT TEMPERATURE	110 °C
GWT	850 °C
GWT NO FLAME (<2sec)	750 °C

?

PITCH BETWEEN SWITCHES

A Pitch 17.5 mm

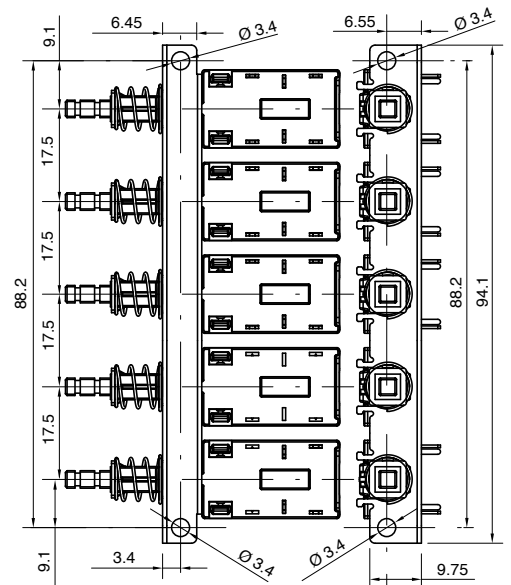

B Pitch 20 mm

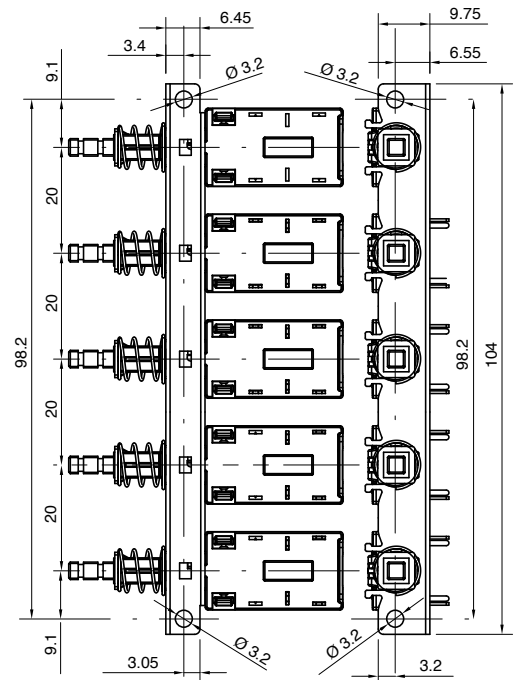

Drilling cut out for PCB

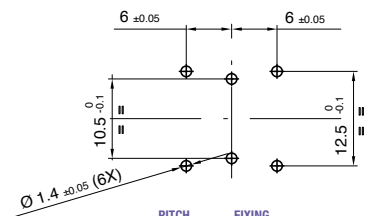

PITCH BETWEEN SWITCHES	FIXING TYPE AND TERMINALS	ACTUATOR TYPE	FUNCTION SWITCH 1	FUNCTION SWITCH 2	FUNCTION SWITCH 3	FUNCTION SWITCH 4	FUNCTION SWITCH 5	RATING
T	5							0 0 0 W

?	?	?	?	?	?	?
FIXING TYPE AND TERMINALS	ACTUATOR TYPE	FUNCTION SWITCH 1	FUNCTION SWITCH 2	FUNCTION SWITCH 3	FUNCTION SWITCH 4	FUNCTION SWITCH 5

?	0	0	0	W
RATING				

14

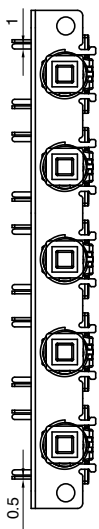

A

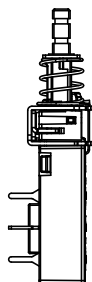

1



2



3



4



7



B



L



M



Z

Reset

1



2



3



4



7



B



L



M



Z

Reset

1



2



3



4



7



B



L

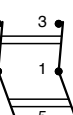

M



Z

Reset

1



2



3



4



7



B



L



M



Z

Reset

1



2



3



4



7



B



L

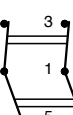

M

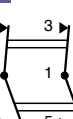

Z

Reset

2

5 (2) A / 250 VAC
T85 °C

6 A / 125 VAC
T65 °C

3

8 (3) A / 250 VAC
T110 °C

6 A / 125 VAC
T65 °C

TM4



Reported to internal components

FEATURES	Control board with 4 "Touch" switches it is available in 5 different and customizable versions
APPLICATION	Cooker hoods
COMPOSITION	<ul style="list-style-type: none"> ■ 1 switch for the hood power light ■ 3 switches for 3 different aspiration speeds ■ 1 micro switch to switch off the aspiration when the drawer is closed



Lever with Subminiature Micro switch

4 Push-button switches

A VERSION - standard version

- 1 switch for the hood power light
- 3 switches for the speed of suction
- 1 micro switch

B VERSION - version with illuminated panel

- 1 switch for the hood power light
- 3 switches for the speed of suction
- 1 micro switch
- 1 lamp for the face illumination

C VERSION - with led display and for low voltage control boards

- 1 switch for the hood power light
- 3 switches for the speed of suction
- 1 micro switch
- 1 electronic control board

D VERSION - value added solution

- 1 micro switch
- 1 SX83 rocker switch (cookerhood light + 2 aspiration speeds)

E VERSION

- version with illuminated touch

DIMENSIONS

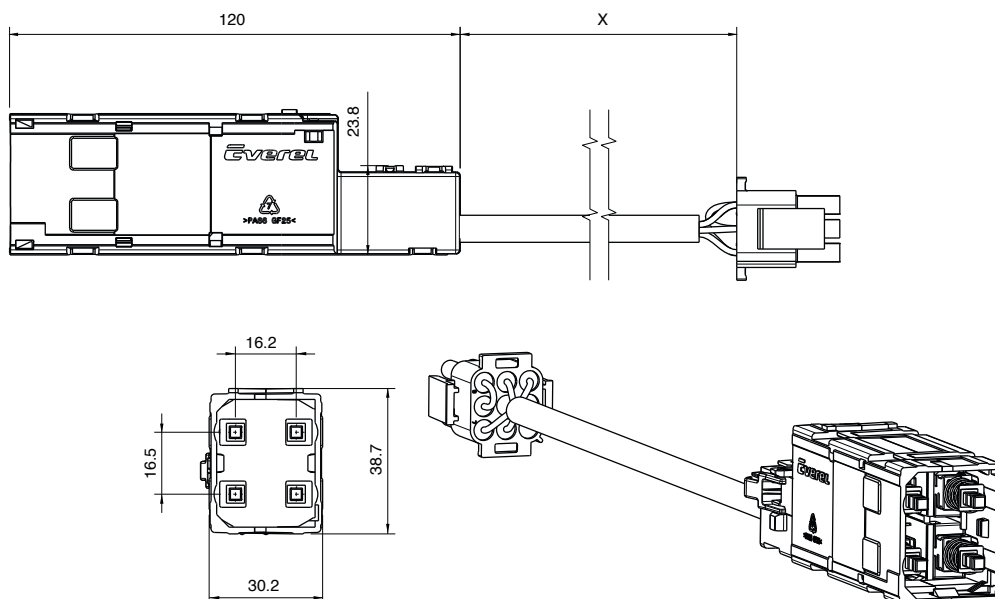

TM5

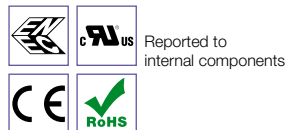

FEATURES	Control board with 5 or 6 push-buttons switches, more features are available on demand
APPLICATION	Cooker hoods
COMPOSITION	<ul style="list-style-type: none"> ■ T5 ■ Box ■ Cables ■ Aesthetic buttons

The control board is a specific customizable solution to better satisfy customer requests:

- Length cables available on request
- Number of switches available on request
- Distance between buttons available in 2 measures: **17.5 and 20 mm**
- Version with indicator light available

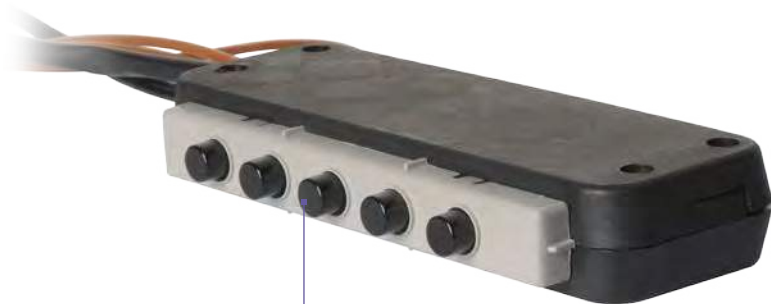

5 Push-button switches

DIMENSIONS

L = Customizable dimensions

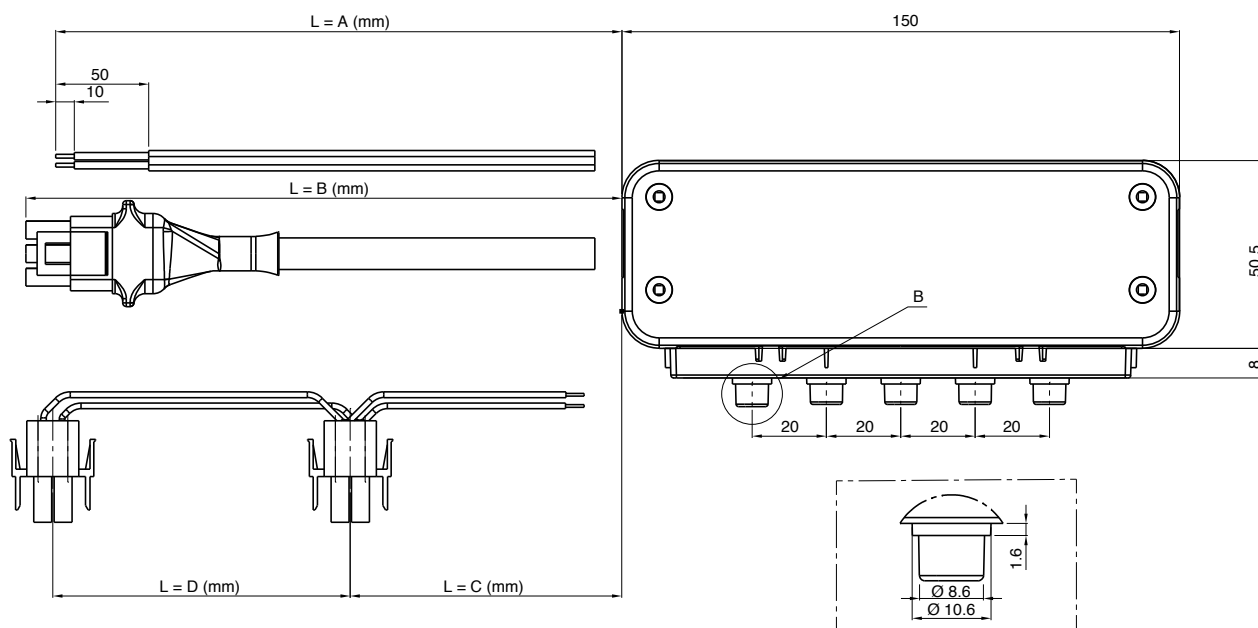
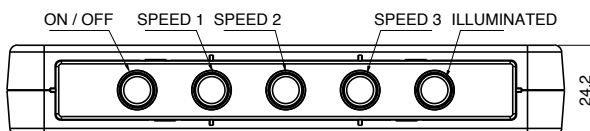

Indicator Lights Switches Size

03



A5

156



A7

156



B5

158



B6

158



B7

160



SP60
indicator light

160



A5

FUNCTION	Indicator light A1 series
AMBIENT TEMPERATURE	125 °C
GWT	850 °C
GWT NO FLAME (<2sec)	650 °C



A 5

DRAWING

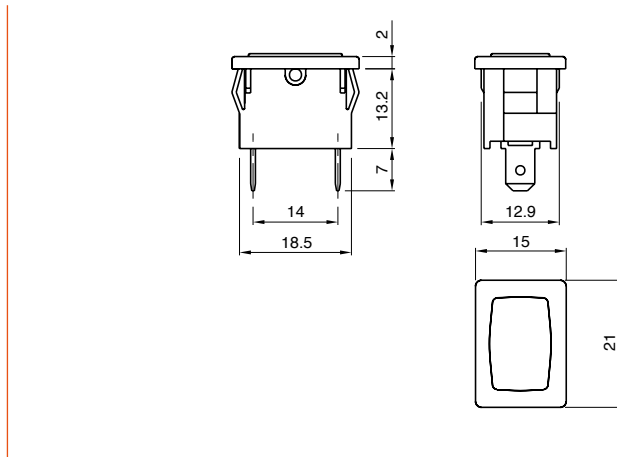

?

TERMINAL

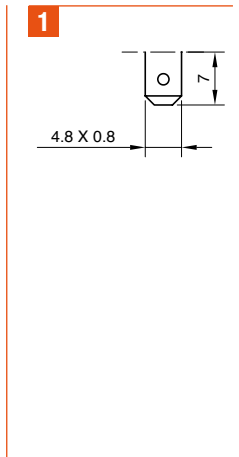

A7

FUNCTION	Indicator light A4 series
AMBIENT TEMPERATURE	125 °C
GWT	850 °C
GWT NO FLAME (<2sec)	650 °C



A 7

DRAWING

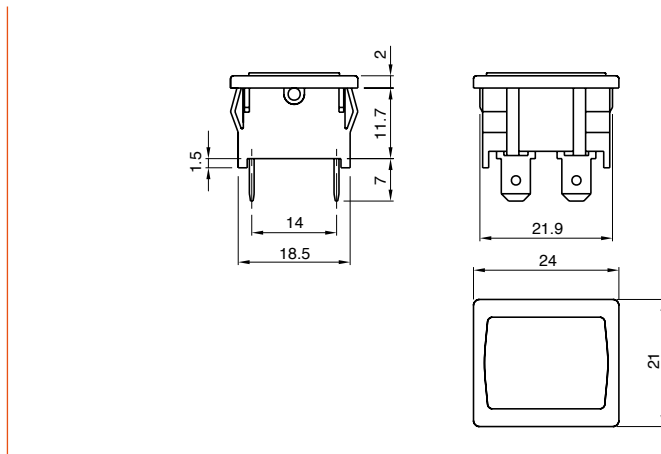

?

TERMINAL

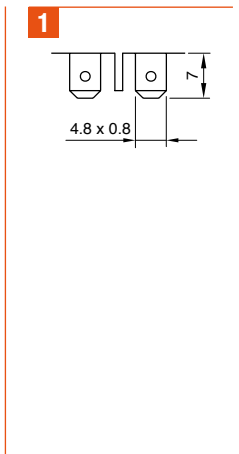

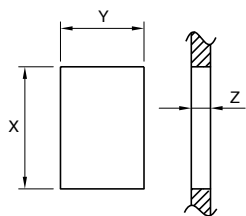

Z	Y	X
0,7 ... 1,25	13,0 ±0,1	19,0 ±0,2
1,25 ... 2,0	13,0 ±0,1	19,3 ±0,2
2,0 ... 3,0	13,0 ±0,1	19,6 ±0,2

A	5	TERMINAL	FUNCTION	RATING	BODY COLOR	LENS COLOR	0	0	0	0	0
---	---	----------	----------	--------	------------	------------	---	---	---	---	---

?	?	?	?
FUNCTION	RATING	BODY COLOR	LENS COLOR

0	0	0	0	0
---	---	---	---	---

1

2

200 - 250 VAC
T125 °C
VDE 710

200 - 250 VAC
 T65 °C
 UL 496
 CSA C22.2

1

black

X

custom

ILLUMINATED

G

red

H

orange

E

green

X

custom

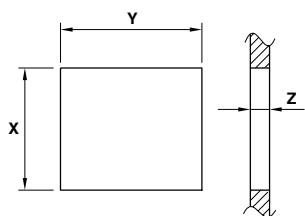

Z	Y	X
0,7 ... 1,25	22,0 ±0,1	19,0 ±0,2
1,25 ... 2,0	22,0 ±0,1	19,3 ±0,2
2,0 ... 3,0	22,0 ±0,1	19,6 ±0,2

A	7	TERMINAL	FUNCTION	RATING	BODY COLOR	LENS COLOR	0	0	0	0	0
---	---	----------	----------	--------	------------	------------	---	---	---	---	---

?	?	?	?
FUNCTION	RATING	BODY COLOR	LENS COLOR

0	0	0	0	0
---	---	---	---	---

1

2

200 - 250 VAC
T125 °C
VDE 710

200 - 250 VAC
 T65 °C
 UL 496
 CSA C22.2

1

black

X

custom

ILLUMINATED

G

red

H

orange

E

green

X

custom



B5

FUNCTION	Indicator light SX81 series
AMBIENT TEMPERATURE	120 °C
GWT	850 °C
GWT NO FLAME (<2sec)	650 °C



B 5

DRAWING

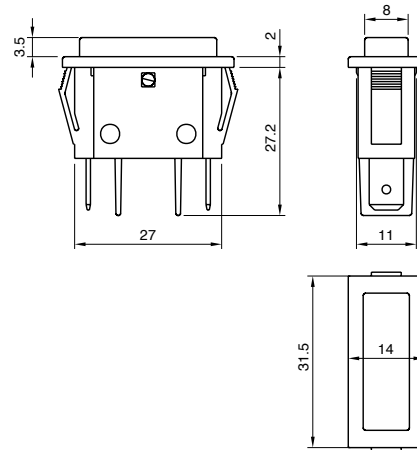

?

TERMINAL

1

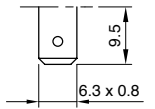

B6

FUNCTION	Indicator light SX83 series
AMBIENT TEMPERATURE	120 °C
GWT	850 °C
GWT NO FLAME (<2sec)	650 °C



B 6

DRAWING

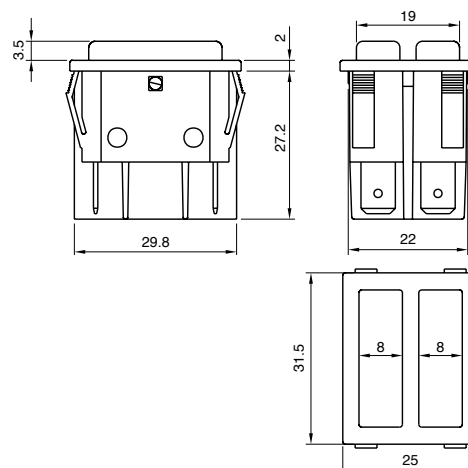

?

TERMINAL

1

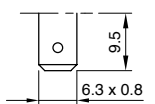

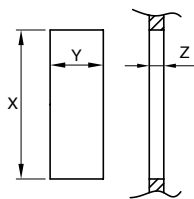

Z	Y	X
0,75 ... 1,25	11,0 ±0,2 0	30,0 0 -0,1
1,25 ... 2,0	11,0 ±0,2 0	30,2 0 -0,1
2,0 ... 3,0	11,0 ±0,2 0	30,6 0 -0,2
3,0 ... 4,0	11,0 ±0,2 0	30,8 0 -0,2

TERMINAL	FUNCTION	RATING	BODY COLOR	LENS COLOR						
B	5				0	0	0	0	0	0

?	?	?	?	0	0	0	0	0	0
---	---	---	---	---	---	---	---	---	---

FUNCTION **RATING** **BODY COLOR** **LENS COLOR**

1

2

200 - 250 VAC
T120 °C
VDE 710

200 - 250 VAC
T65 °C
UL 496
CSA C22.2

1

black

X

custom

ILLUMINATED

G

red

H

orange

E

green

X

custom

0	0	0	0	0	0
---	---	---	---	---	---

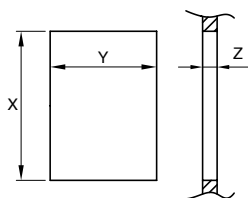

Z	Y	X
0,75 ... 1,25	22,0 ±0,2 0	30,0 0 -0,1
1,25 ... 2,0	22,0 ±0,2 0	30,2 0 -0,1
2,0 ... 3,0	22,0 ±0,2 0	30,6 0 -0,2
3,0 ... 4,0	22,0 ±0,2 0	30,8 0 -0,2

TERMINAL	FUNCTION	RATING	BODY COLOR	LENS COLOR L	LENS COLOR R					
B	6					0	0	0	0	0

?	?	?	L	R	?	?	0	0	0	0	0
---	---	---	---	---	---	---	---	---	---	---	---

FUNCTION **RATING** **BODY COLOR** **LENS COLOR**

1

2

200 - 250 VAC
T120 °C
VDE 710

200 - 250 VAC
T65 °C
UL 496
CSA C22.2

1

black

X

custom

ILLUMINATED

G

red

H

orange

E

green

X

custom

0	0	0	0	0
---	---	---	---	---

**B7**

FUNCTION	Indicator light SX82 series
AMBIENT TEMPERATURE	120 °C
GWT	850 °C
GWT NO FLAME (<2sec)	650 °C

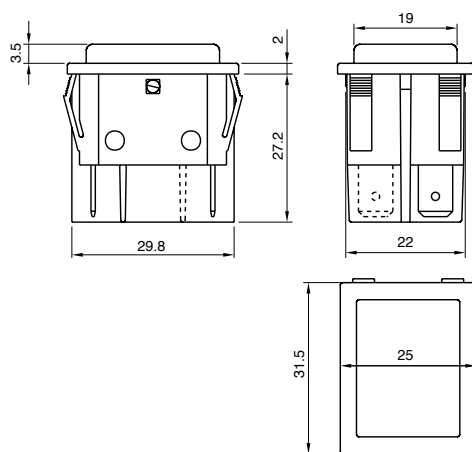
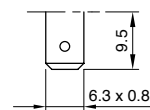
**B 7****DRAWING****?****TERMINAL****1****SP60**
INDICATOR LIGHT

FUNCTION	Indicator light SP60 series
AMBIENT TEMPERATURE	120 °C
GWT	850 °C
GWT NO FLAME (<2sec)	650 °C

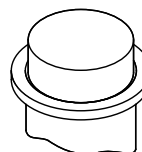
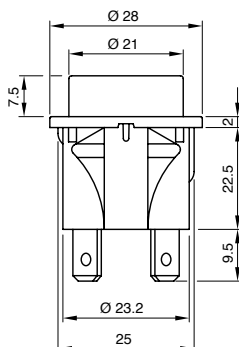
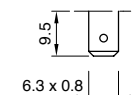
**S P 6 0****DRAWING****?****TERMINAL****3**

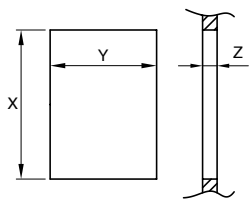

Z	Y	X
0,75 ... 1,25	22,0 ±0,2 0	30,0 0 -0,1
1,25 ... 2,0	22,0 ±0,2 0	30,2 0 -0,1
2,0 ... 3,0	22,0 ±0,2 0	30,6 0 -0,2
3,0 ... 4,0	22,0 ±0,2 0	30,8 0 -0,2

TERMINAL	FUNCTION	RATING	BODY COLOR	LENS COLOR						
B	7				0	0	0	0	0	0

FUNCTION	RATING	BODY COLOR	LENS COLOR
?	?	?	?

0	0	0	0	0	0
---	---	---	---	---	---

1

2

200 - 250 VAC
T120 °C
VDE 710

200 - 250 VAC
 T65 °C
 UL 496
 CSA C22.2

1

black

X

custom

ILLUMINATED

G

red

H

orange

E

green

X

custom

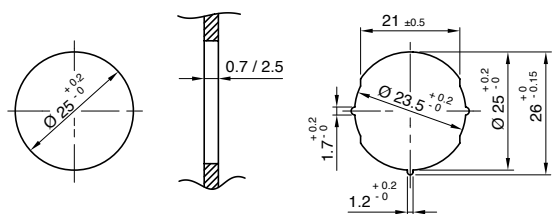

TERMINAL	FUNCTION	RATING	BODY COLOR	LENS COLOR						
S	P	6	0					0	0	0

FUNCTION	RATING	BODY COLOR	LENS COLOR
?	?	?	?

0	0	0	0
---	---	---	---

9

2

220 VAC
T120 °C
VDE 710

220 VAC
 T65 °C
 UL 496
 CSA C22.2

1

black

X

custom

ILLUMINATED

G

red

H

orange

E

green

X

custom

Indicator Lights

03

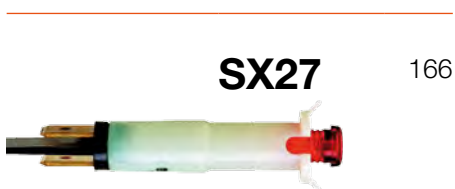

INDICATOR LIGHTS

FUNCTIONS	<ul style="list-style-type: none"> ■ Neon or fluorescent lamp, with or without anti-luminescence resistor ■ Incandescent lamp ■ LED in AC or DC version
VOLTAGE	From 2 VAC to 400 VAC
MAX TEMPERATURE	From 75 °C to 150 °C
GWT	850 °C
GWT NO FLAME (<2sec)	650 °C



SERIES

CUT OUT

17



Custom*



21



Custom



5.4 x 9 mm
th 1.5 mm

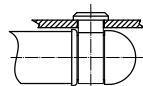

2.5 x 11.6 mm



DRAWING

1

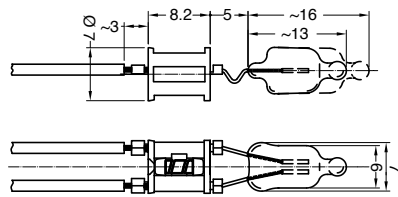

3

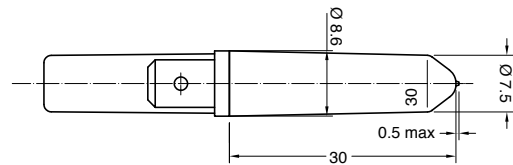

Accessory lenses available separately (pages 172-173)

4

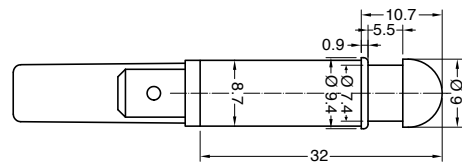

P Drawing 4 + round lens

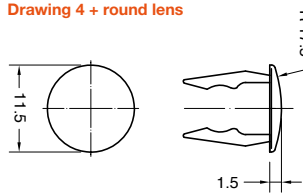

Q Drawing 4 + square lens

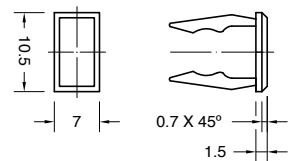

Lens available also separately SX21T542...

Lens available also separately SX21T544...

8

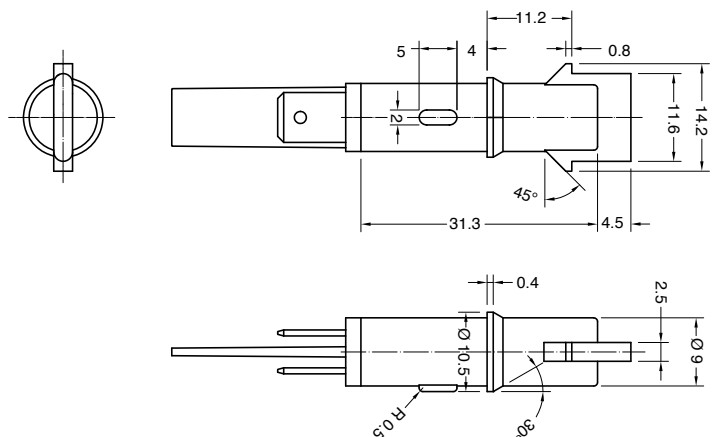

S	X	SERIES	DRAWING	TERMINAL	FUNCTION	VOLTAGE	TEMP.	COLOUR	WIRES	0	0

?	?	?	?	?	?	?	?	?	?	?	?	0	0
---	---	---	---	---	---	---	---	---	---	---	---	---	---

TERMINAL

1 Series 21
Tabs 6.3 x 0.8

A Series 17
Wires

C Series 21
Signal Click

K Series 21
Wires crimped

R Series 21
Wires sealed

FUNCTION

1 Series 17 - 21

Neon or Fluorescent lamp

2 Series 21

Neon or Fluorescent lamp with anti-luminescence

3 Series 21

Incandescent lamp

5 Series 21

LED
DC or AC current
2 ÷ 24 V

6 Series 21
Terminal 1

LED
AC current
110 ÷ 250 V

7 Series 21
Terminal C - K - R

LED
AC current
110 ÷ 250 V

VOLTAGE

1 Function 5
2 V

2 Function 3 - 5
12 V

3 Function 3 - 5
24 V

4 Function 1 - 2 - 6 - 7
110 V

5 Function 1 - 2 - 6 - 7
125 V

6 Function 1 - 2 - 6 - 7
230 V

7 Function 1 - 2 - 6 - 7
250 V

8 Function 1 - 2
400 V

VDE or UL certified

?
Available on demand

* UL certification not available

X
Custom

TEMPERATURE

A
T 75 °C

1 Function 1-2-3
T 90 °C

2 Function 1 - 2
T 120 °C

3 Function 1 - 2
T 150 °C

COLOUR

SERIES 17
NO LENS ☼

0 red light

1 green light

SERIES 21

ILLUMINATED ☼

Drawing 3 - 4
L white

Drawing P - Q - 8
G red

H orange

E green

L white

X **?**
custom

WIRES

000 Terminal 1 - 7 - C
Indicator light without wires

??? Terminal A - K - R
Indicator light with wires

Wires Materials:
 ■ PVC (up to T90 °C)
 ■ SILICONE (up to T200 °C)

Wires Lengths:
 from 60 mm to 600 mm
 (special version available up to 1.450 mm)

Wires Ends:
 ■ pre-stripped (from 5.5 to 18 mm)
 ■ stripped (from 5.5 to 18 mm)
 ■ not stripped
 ■ crimp terminals

S X ? ?

SERIES

CUT OUT

?

DRAWING

24



○
ø 6 mm
th 0.5 ... 2 mm



○
ø 6 mm
th 0.5 ... 1 mm

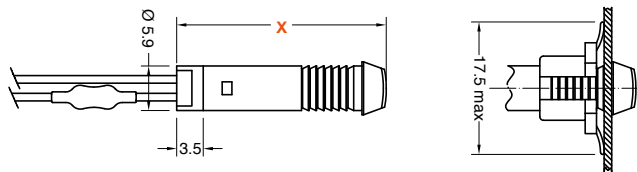

0 X = 24.2 mm

2 X = 23 mm

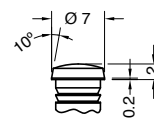
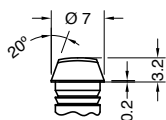

5

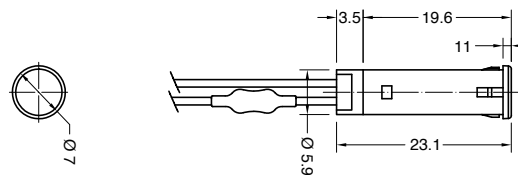

27



○
ø 6 mm
th 0.5 ... 3 mm

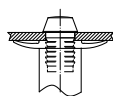

5 No lens 2 clips

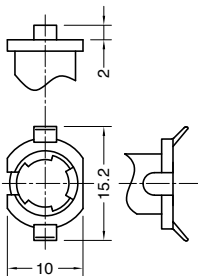

0 Drawing 5 + lens

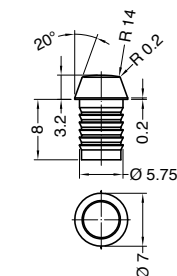

Lens available also separately SX27T0...

2 Drawing 5 + lens

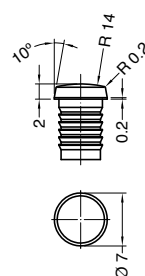

Lens available also separately SX27T2...

8 Drawing 5 + lens

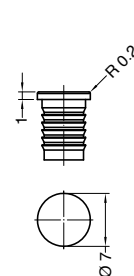

Lens available also separately SX27T8...

N No lens 4 clips

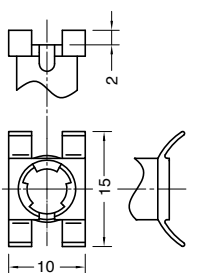

A Drawing N + lens

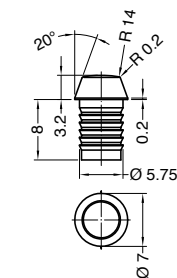

Lens available also separately SX27T0...

C Drawing N + lens

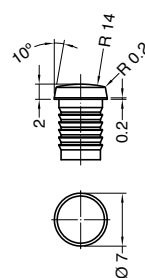

Lens available also separately SX27T2...

E Drawing N + lens

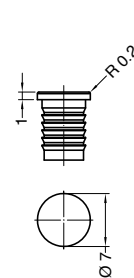

Lens available also separately SX27T8...

Further lens shapes available on demand

S	X	SERIES	DRAWING	TERMINAL	FUNCTION	VOLTAGE	TEMP.	COLOUR	WIRES	0	0
---	---	--------	---------	----------	----------	---------	-------	--------	-------	---	---

?	?	?	?	?	?	?	?	?	?	0	0
---	---	---	---	---	---	---	---	---	---	---	---

TERMINAL

1 Series 27
Tabs 6.3 x 0.8

C Series 27
Signal Click

K Series 27
Wires crimped

P Series 24
Wires locked with plug

R Series 27
Wires sealed

FUNCTION

1 Series 24 - 27

Neon or Fluorescent lamp

2 Series 27

Neon or Fluorescent lamp with anti-luminescence

3 Series 27

Incandescent lamp

5 Series 24 - 27
Terminal 1 - P

LED
DC or AC current
2 ÷ 24 V

6 Series 24 - 27
Terminal 1 - P

LED
AC current
110 ÷ 250 V

7 Series 27
Terminal C - K - R

LED
AC current
110 ÷ 250 V

VOLTAGE

1 Function 5
2 V

2 Function 3 - 5
12 V

3 Function 3 - 5
24 V

4 Function 1 - 2 - 6 - 7
110 V

5 Function 1 - 2 - 6 - 7
125 V

6 Function 1 - 2 - 6 - 7
230 V

7 Function 1 - 2 - 6 - 7
250 V

8 Function 1 - 2
400 V

?
VDE or UL certified
Available on demand

X
Custom

TEMPERATURE

A
T 75 °C

1 Function 1 - 2 - 3
T 90 °C

2 Function 1 - 2
T 120 °C

3 Function 1 - 2
T 150 °C

COLOUR

SERIES 24
ILLUMINATED ✨

G red

H orange

E green

L white

SERIES 27
Drawing 5 - N

NO LENS ✨

0 red light

1 green light

Drawing 0 - 2 - 8 - A - C - E

ILLUMINATED ✨

G red

H orange

E green

L white

X ?
custom

WIRES

000 Terminal 1 - C
Indicator light without wires

??? Terminal K - P - R
Indicator light with wires

Wires Material:

- PVC (up to T90 °C)
- SILICONE (up to T200 °C)

Wires Length:
from 60 mm to 600 mm (special version available up to 1.450 mm)

Wires Ends:

- pre-stripped (from 5.5 to 18 mm)
- stripped (from 5.5 to 18 mm)
- not stripped
- crimp terminals

S X ? ?

SERIES

CUT OUT

?

DRAWING

27



○
ø 8 mm
th 0.5 ... 2 mm

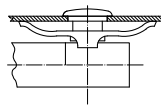

28



Custom

M No lens

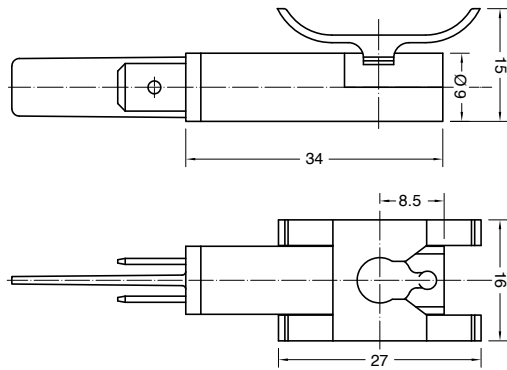

P Drawing M + lens

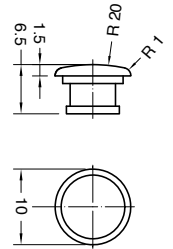

Lens available also separately SX27TP...

9 No lens

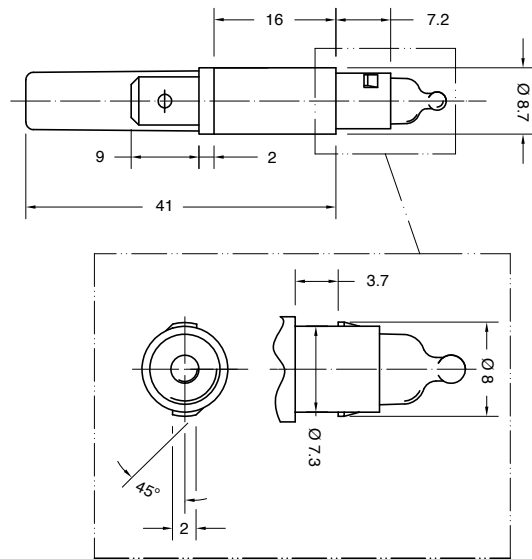

6 Drawing 9 + lens

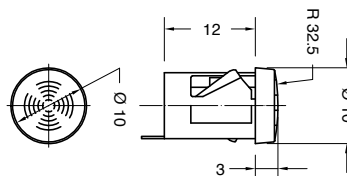

Lens available also separately SX28T6...

F Drawing 9 + lens

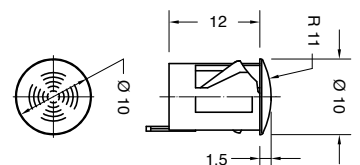

Lens available also separately SX28TF...

Further lens shapes available on demand

H One piece

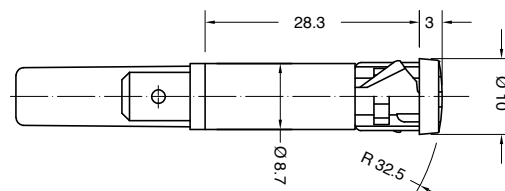

○
ø 9 mm
th 0.8 ... 2 mm



○
ø 9 mm
th 0.8 ... 2 mm

S	X	SERIES	DRAWING	TERMINAL	FUNCTION	VOLTAGE	TEMP.	COLOUR	WIRES	0	0
---	---	--------	---------	----------	----------	---------	-------	--------	-------	---	---

?	?	?	?	?	?	?	?	?	?	0	0
---	---	---	---	---	---	---	---	---	---	---	---

TERMINAL	FUNCTION	VOLTAGE	TEMPERATURE	COLOUR	WIRES
----------	----------	---------	-------------	--------	-------

1 Series 27 - 28
Tabs 6.3 x 0.8

C Series 27 - 28
Signal Click

K Series 28
Wires crimped

R Series 27 - 28
Wires sealed

1 Series 27 - 28

Neon or Fluorescent lamp

2 Series 27 - 28

Neon or Fluorescent lamp with anti-luminescence

3 Series 27 - 28

Incandescent lamp

5 Series 27 - 28

LED
DC or AC current
2 ÷ 24 V

6 Series 28
Terminal 1

LED
AC current
110 ÷ 250 V

7 Series 28
Terminal C - K - R

LED
AC current
110 ÷ 250 V

1 Function 5
2 V

2 Function 3 - 5
12 V

3 Function 3 - 5
24 V

4 Function 1 - 2 - 6 - 7
110 V

5 Function 1 - 2 - 6 - 7
125 V

6 Function 1 - 2 - 6 - 7
230 V

7 Function 1 - 2 - 6 - 7
250 V

8 Function 1 - 2
400 V

?
Available on demand

X
Custom

A
T 75 °C

1 Function 1 - 2 - 3
T 90 °C

2 Function 1 - 2
T 120 °C

3 Function 1 - 2
T 150 °C

NO LENS ☼

0 red light

1 green light

ILLUMINATED ☼

G red

H orange

E green

L white

X **?**
custom

000 Terminal 1 - C
Indicator light without wires

??? Terminal K - R
Indicator light with wires

- Wires Material:**
- PVC (up to T90 °C)
 - SILICONE (up to T200 °C)
- Wires Length:**
from 60 mm to 600 mm (special version available up to 1.450 mm)
- Wires Ends:**
- pre-stripped (from 5.5 to 18 mm)
 - stripped (from 5.5 to 18 mm)
 - not stripped
 - crimp terminals

S X ? ?

SERIES

CUT OUT

?

DRAWING

31



○
ø 10 mm
th 0.5 ... 9 mm



○
ø 10 mm
th 0.5 ... 9 mm

33



○
ø 10 mm
th 0.8 ... 2 mm



○
ø 10 mm
th 0.8 ... 2 mm



○
ø 10 mm
th 0.8 ... 2 mm

2

Mounted ring

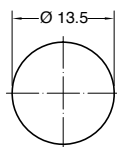

B

Unmounted ring

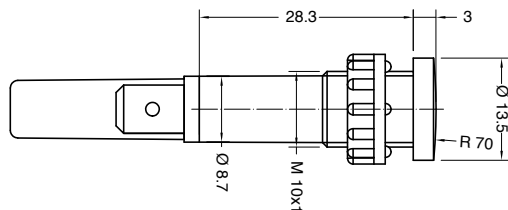

9

Mounted ring

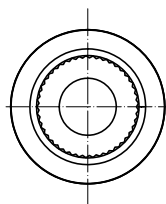

D

Unmounted ring

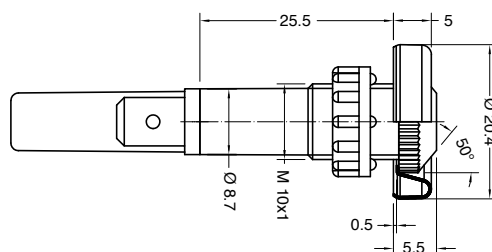

2

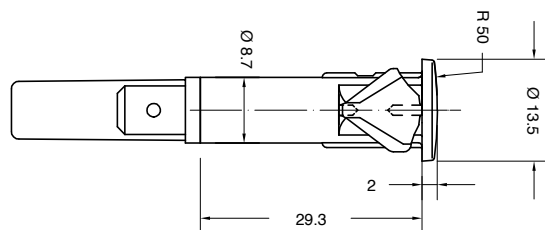
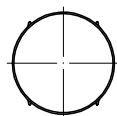

C

With antirotation rib

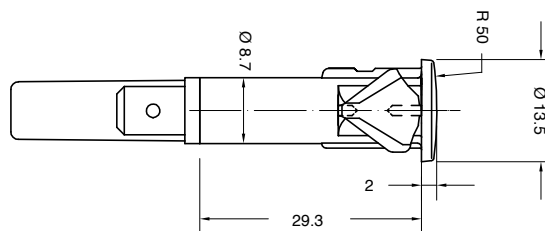
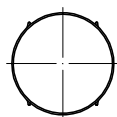

H

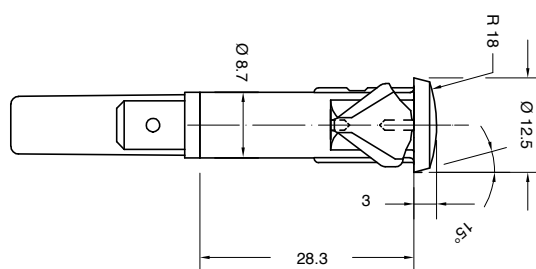
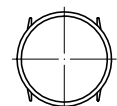

S	X	SERIES	DRAWING	TERMINAL	FUNCTION	VOLTAGE	TEMP.	COLOUR	WIRES	0	0

?	?	?	?	?	?	?	?	?	?	0	0
---	---	---	---	---	---	---	---	---	---	---	---

TERMINAL	FUNCTION	VOLTAGE	TEMPERATURE	COLOUR	WIRES
----------	----------	---------	-------------	--------	-------

1 Tabs 6.3 x 0.8

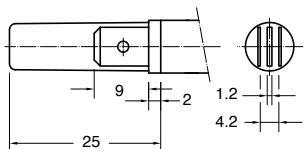

C Signal Click

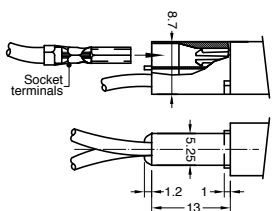

K Wires crimped

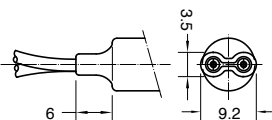

R Wires sealed

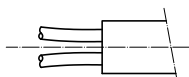

1



Neon or Fluorescent lamp

2



Neon or Fluorescent lamp with anti-luminescence

3



Incandescent lamp

5



LED
DC or AC current
2 ÷ 24 V

6 Terminal 1



LED
AC current
110 ÷ 250 V

7 Terminal C - K - R



LED
AC current
110 ÷ 250 V

1 Function 5

2 V

2 Function 3 - 5

12 V

3 Function 3 - 5

24 V

4 Function 1 - 2 - 6 - 7

110 V

5 Function 1 - 2 - 6 - 7

125 V

6 Function 1 - 2 - 6 - 7

230 V

7 Function 1 - 2 - 6 - 7

250 V

8 Function 1 - 2

400 V

VDE or UL certified

?

Available on demand

X

Custom

A

T 75 °C

1 Function 1 - 2 - 3

T 90 °C

2 Function 1 - 2

T 120 °C

3 Function 1 - 2

T 150 °C

ILLUMINATED



000 Terminal 1 - C

Indicator light without wires

??? Terminal K - R

Indicator light with wires

Wires Material:

- PVC (up to T90 °C)
- SILICONE (up to T200 °C)

Wires Length:

from 60 mm to 600 mm (special version available up to 1.450 mm)

Wires Ends:

- pre-stripped (from 5.5 to 18 mm)
- stripped (from 5.5 to 18 mm)
- not stripped
- crimp terminals

S X ? ?

SERIES

CUT OUT

?

DRAWING

41



○
ø 12 mm
th 0.8 ... 2 mm

1

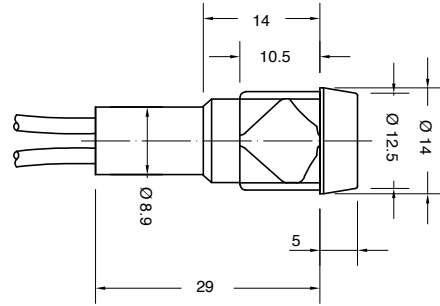

○
ø 12 mm
th 0.8 ... 2 mm

2

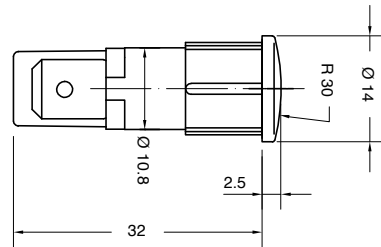
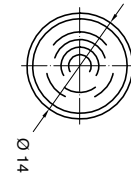

43



○
ø 13 mm
th 0.8 ... 2 mm

2

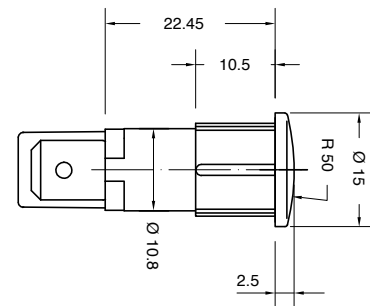
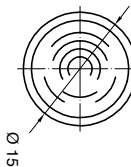

ACCESSORY LENSES FOR SERIES SX213...

SX21T511...

○
ø 12 mm
th 0.8 ... 6.5 mm

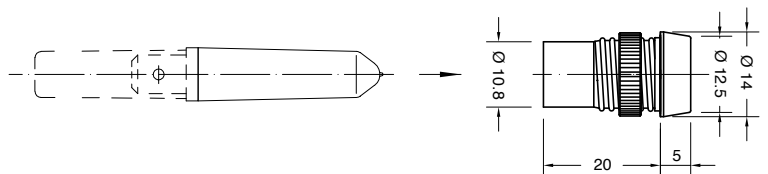





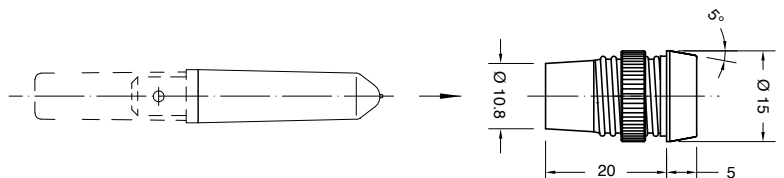

SX21T531...

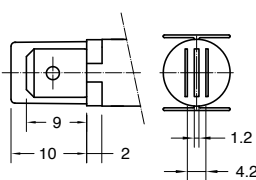
○
ø 13 mm
th 0.8 ... 6.5 mm

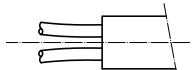

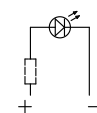
S	X	SERIES	DRAWING	TERMINAL	FUNCTION	VOLTAGE	TEMP.	COLOUR	WIRES	0	0
---	---	--------	---------	----------	----------	---------	-------	--------	-------	---	---

?	?	?	?	?	?	?	?	?	?	?	?	0	0
TERMINAL	FUNCTION	VOLTAGE	TEMPERATURE	COLOUR	WIRES								
<p>1 Series 41 - 43 Tabs 6.3 x 0.8</p> 	<p>1</p> 	<p>1 Function 5 2 V</p> <p>2 Function 3 - 5 12 V</p> <p>3 Function 3 - 5 24 V</p> <p>4 Function 1 - 2 - 6 - 7 110 V</p> <p>5 Function 1 - 2 - 6 - 7 125 V</p> <p>6 Function 1 - 2 - 6 - 7 230 V</p> <p>7 Function 1 - 2 - 6 - 7 250 V</p> <p>8 Function 1 - 2 400 V</p> <p>VDE or UL certified</p> <p>? Available on demand</p> <p>X Custom</p>	<p>A T 75 °C</p> <p>1 Function 1-2-3 T 90 °C</p> <p>2 Function 1 - 2 T 120 °C</p> <p>3 Function 1 - 2 T 150 °C</p>	<p>ILLUMINATED ✨</p> <p>G red</p> <p>H orange</p> <p>E green</p> <p>L white</p> <p>X ? custom</p>	<p>000 Terminal 1 - C Indicator light without wires</p> <p>??? Terminal K - R Indicator light with wires</p> <p>Wires Material:</p> <ul style="list-style-type: none"> PVC (up to T90 °C) SILICONE (up to T200 °C) <p>Wires Length: from 60 mm to 600 mm (special version available up to 1.450 mm)</p> <p>Wires Ends:</p> <ul style="list-style-type: none"> pre-stripped (from 5.5 to 18 mm) stripped (from 5.5 to 18 mm) not stripped crimp terminals 								
<p>R Series 41 Wires sealed</p> 	<p>2</p> 												
	<p>3</p> 												
	<p>5</p> 												
	<p>6 Terminal 1</p> 												
	<p>7 Terminal R</p> 												

SX21T572...
with antirotation rib



 ø 10.2 mm
 th 0.8 ... 2 mm

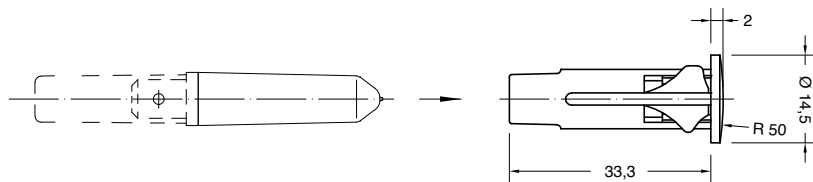

SX21T578...
without antirotation rib



 ø 13 mm
 th 0.5 ... 2.5 mm

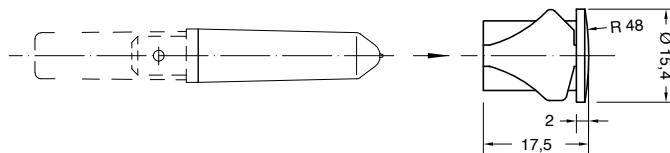

SX21T592...

Selectors

04

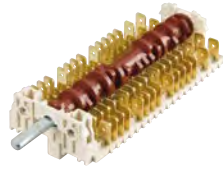

HE

176



5HE 7TAKT

180



5HE 7TAKT DUO

182



HT

184

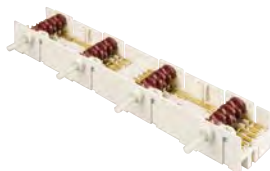

5HE 4 BLOCK

186

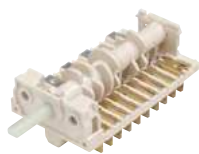

CH

187



2CH WITH ENCODER

188

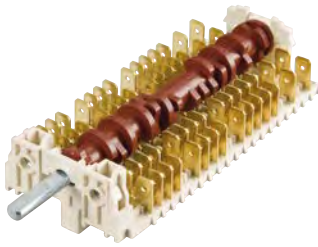

HE



TYPICAL APPLICATIONS	Function selector switch
WIRING DIAGRAMS	2 - 14 positions Rast 5 connectors
GWFI	850 °C
GWIT	750 °C

Rotary switches with a wide range of configurations. 6 types of housing available, different for the maximum number of contacts. HE series is automatically assembled in a great variety of configurations.

- Function selector switch
- Child lock - push to turn feature on demand
- Coupling with encoder available
- Flexibility of wiring diagrams
- Different "click" or frictional feeling
- Metal or plastic shafts with different lengths: 12,5 - 46 mm (standard shafts protude: 23 mm)

EXAMPLE OF 11HE WITH 8 CONTACTS

Easy wiring with multiple plug (Rast 5) or single terminals 6,3 mm

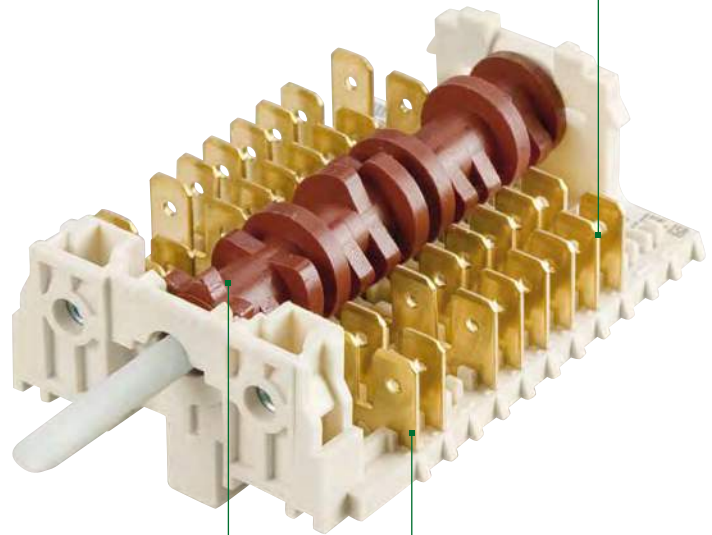

2 - 14 positions

Standard double contact

Rating

16 A / 250 VAC - 10E3
 12 A / 400 VAC - 30E3
 0,25 A / 250 VAC - 30E3
 T150 °C
 According to
 EN61058-1 standard

16 A / 250 VAC
 T120 °C
 According to
 UL 1054



TYPICAL TERMINALS

- Single terminals
- Double terminals
- Chopped
 - left
 - center
 - right

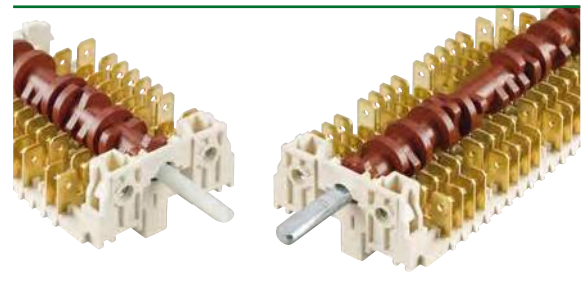

TYPES OF SHAFT

Plastic

Metal

DIMENSIONS

Standard version

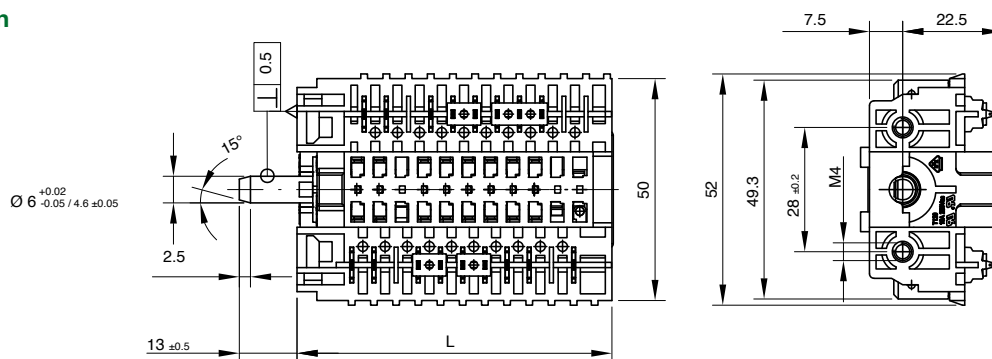

Thermostat version

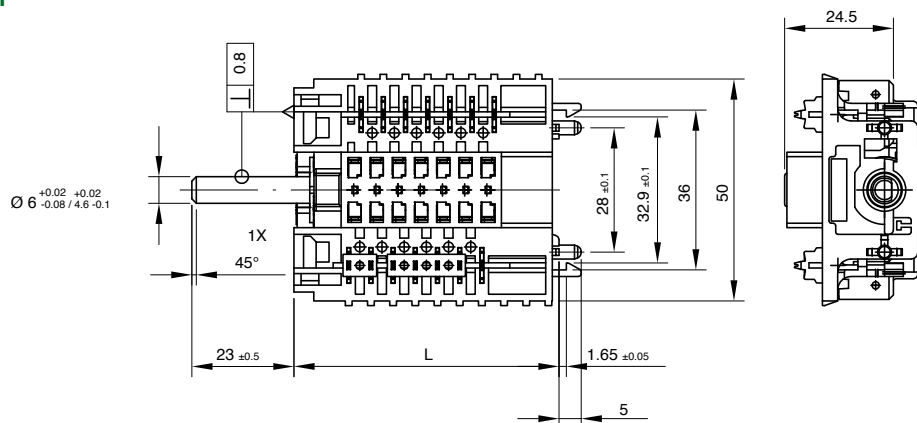

TECHNICAL FEATURES

Version	No. contacts	Length	
		L	L thermostat version
3HE	up to 3	30	38
5HE	up to 5	40	48
7HE	up to 7	50	58
11HE	up to 11	70	78
15HE	up to 15	90	98
19HE	up to 19	110	118

OPTIONS

Higher number of contacts, multiple versions, possibility to use accessories are the main features of HE series.

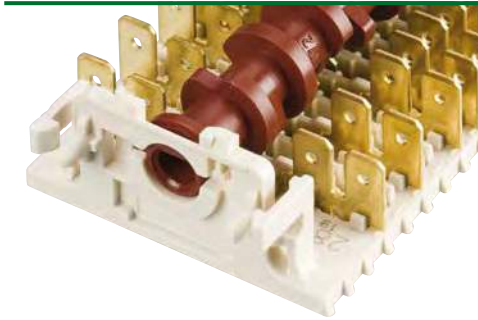

Body with accessory holder

- Possibility to use in conjunction with a capillary thermostat or an encoder

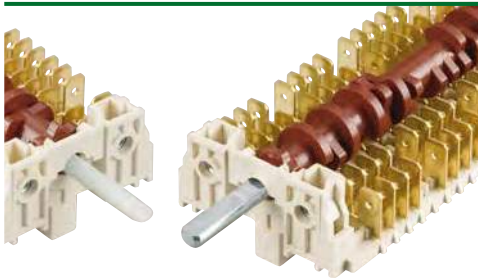

Shaft

- Metal or plastic shaft with length on demand (12.5 - 46 mm)
- Standard shaft length: 23.5 mm

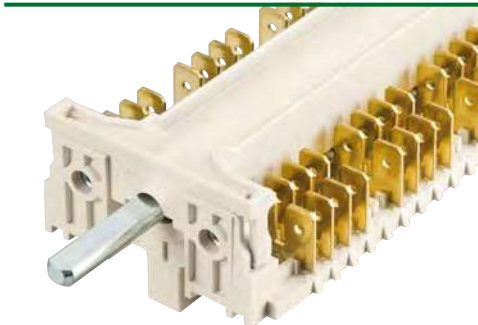

Cam cover

- Cam cover protects cam and contacts from dirt and waste of cooking.
- Note: cam cover is available for 11 and 19 versions.

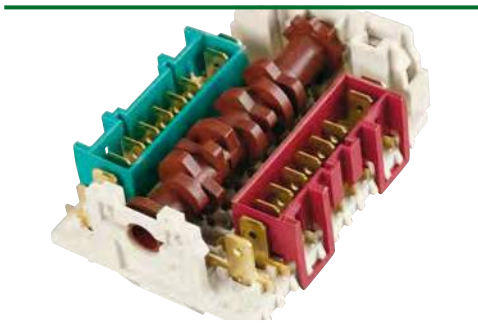

Terminal housing

- Various dimensions of terminal housing: for 2 - 4 - 6 connections.
- Terminal housing available only for single terminal version.

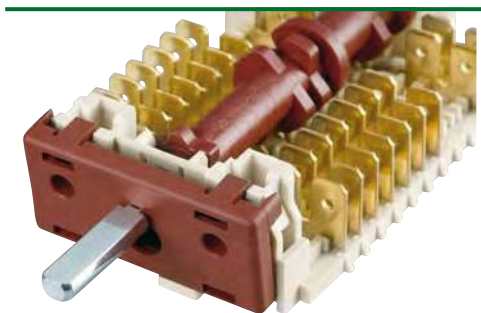

Child lock - push to turn feature

- Push to turn safety feature available.

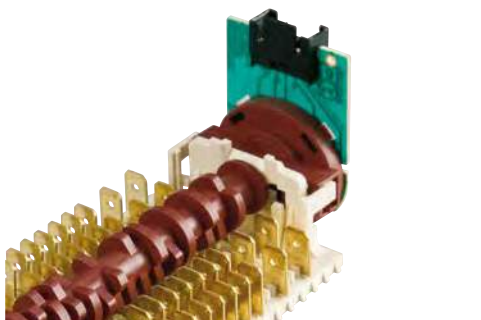

Coupling with encoder

- HE series can be coupled to an electromechanical to control electrical and power signals.

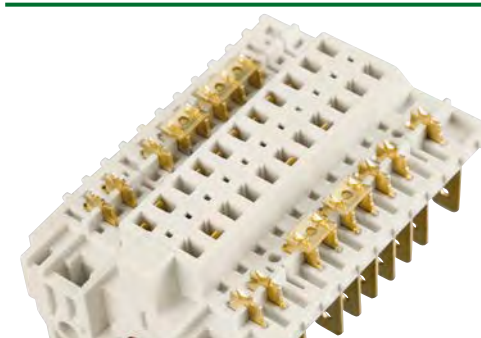

Bridges

- The use of bridges between contacts increases range of combinations.
- For every line the number of bridges can vary between 0 up to 5.
- It can be joined up to 7 contacts.

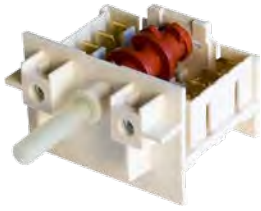

5HE 7TAKT



On demand

TYPICAL APPLICATIONS	Hobs control
WIRING DIAGRAMAS	7 positions
GWFI	850 °C
GWIT	750 °C

Rotary switches with different mounting solution available, 7 positions, with electric rating up to 12A. Ideal for hobs control, with a terminal housing conjuncted to the body.

- Standard connecting with single terminals 6,3 mm
- Different mounting solutions available:
snap-in, nuts or screw fixing
- 30.000 cycles
- Plastic shafts with different lengths (16 - 31 mm)

Rating

12 A / 400 VAC 30E3

T150 °C

According to

EN61058-1 standard

16 A / 250 VAC

T120 °C

According to

UL 1054

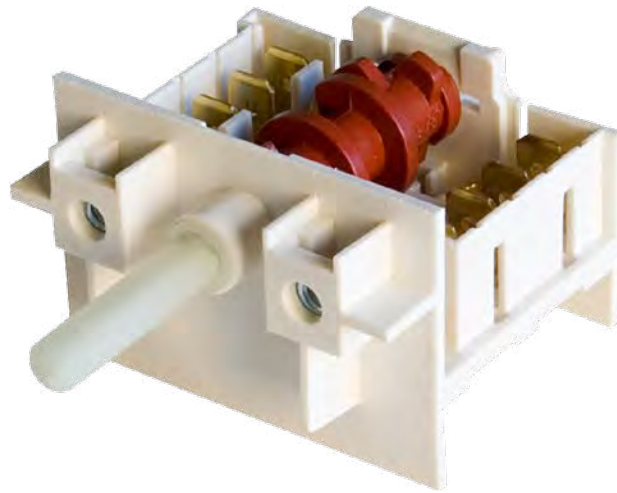

TECHNICAL FEATURES

Rast 6,5 multiple connection.

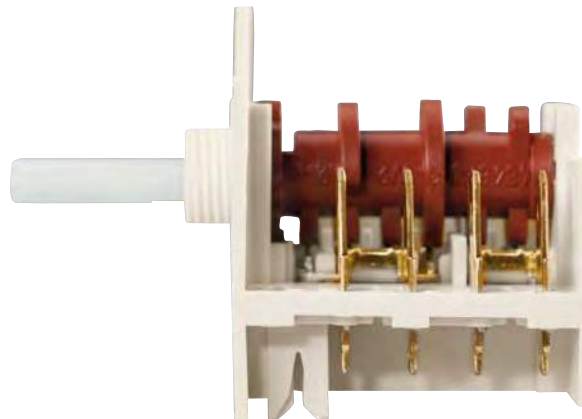

DIMENSIONS

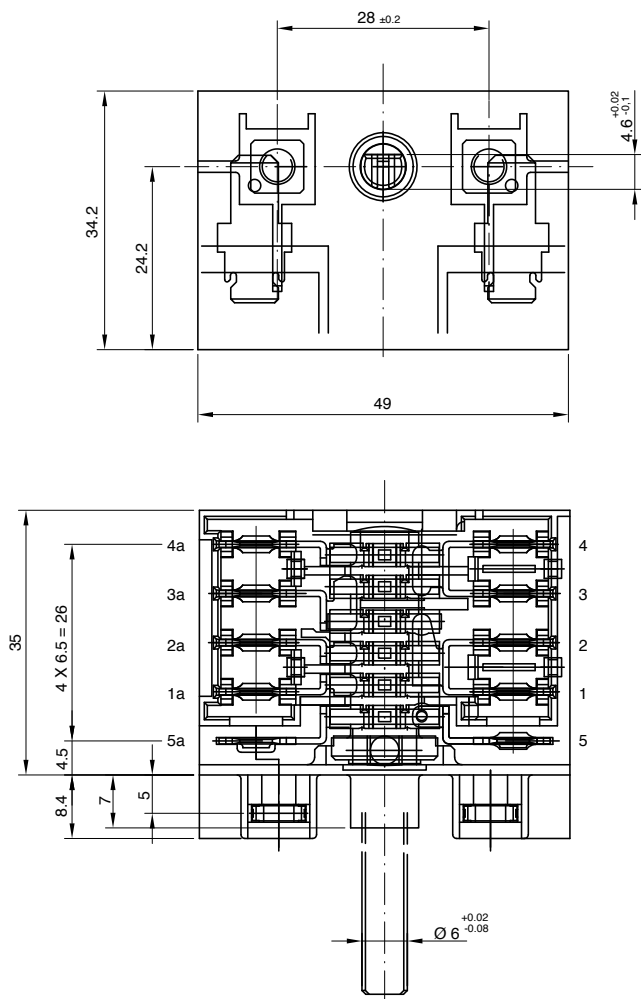

CONTACT SEQUENCE

Pos.	Ang.	P3		P1		P2	
		5a	1a-2a	1a-2a	3a-4a	3a-4a	3a-4a
		5	1	1	3-3	4	
		5	2	2	3-3	4	
0	0°						
1	51,4°	■	■	■		■	■
2	102,8°	■		■		■	■
3	154,2°	■		■		■	
4	205,6°	■		■			■
5	257,0°	■			■		■
6	308,4°	■	■			■	

SOLUTIONS

Nut Fixing



Screw fixing

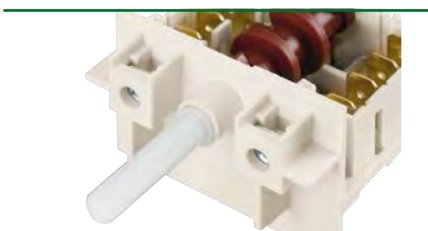

Snap-in fixing



CUT OUT

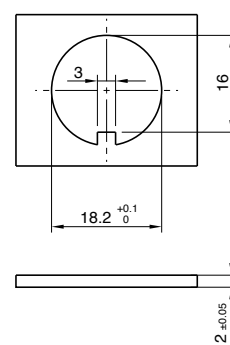
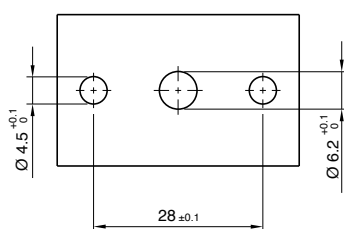
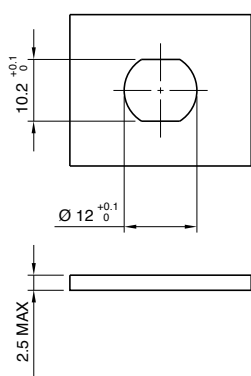

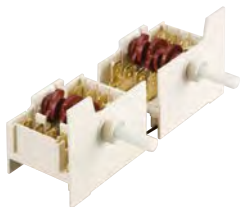

5HE 7TAKT DUO



TYPICAL APPLICATIONS	Hobs control
WIRING DIAGRAMAS	7 positions
GWFI	850 °C
GWFI	750 °C

This series is composed of two 5HE 7TAKT rotary selectors, 3 different distances of axis available (55, 60 and 65 mm). Each selector has 7 positions, electric rating up to 12A and different mounting solutions. Duo block permits to make the wiring easier.

- Standard connecting with single terminals 6,3 mm
- Different mounting solutions available: snap-in, nuts or central mounting
- Metal or plastic shafts with different lengths
- Rast 6,5 multiple connection available
- Metal or plastic shafts with different lengths:
(16 - 31 mm)

EXAMPLE OF 5HE 7TAKT DUO WITH NUTS

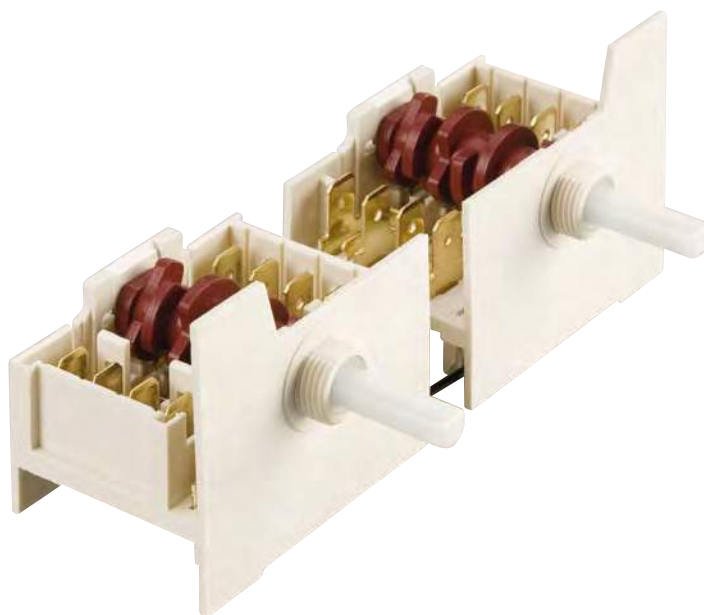

Rating

12 A / 400 VAC 30E3

T150 °C

According to

EN61058-1 standard

16 A / 250 VAC

T120 °C

According to

UL 1054

TECHNICAL FEATURES

Various distances of axis available:

55, 60 and 65 mm.

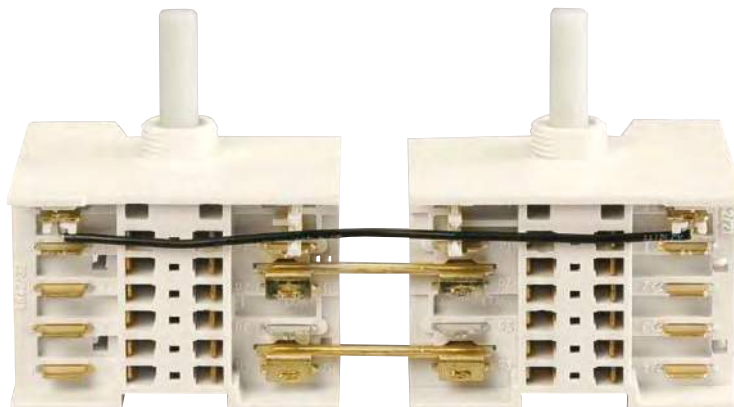

DIMENSIONS

Screw fixing version

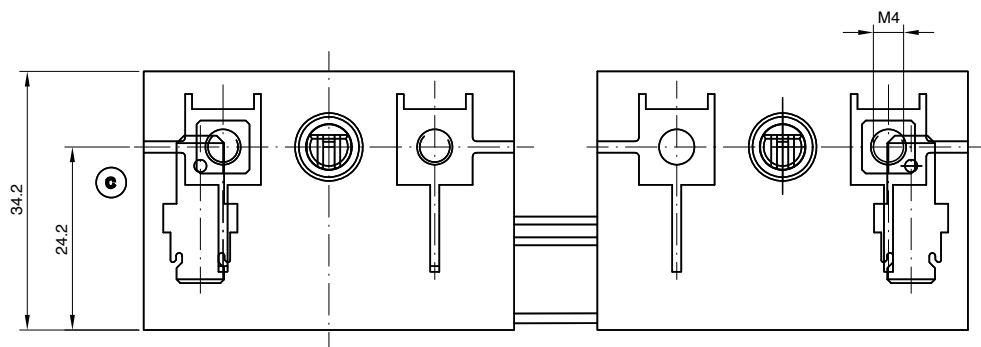

60 mm interaxis version
(55 and 65 mm available)

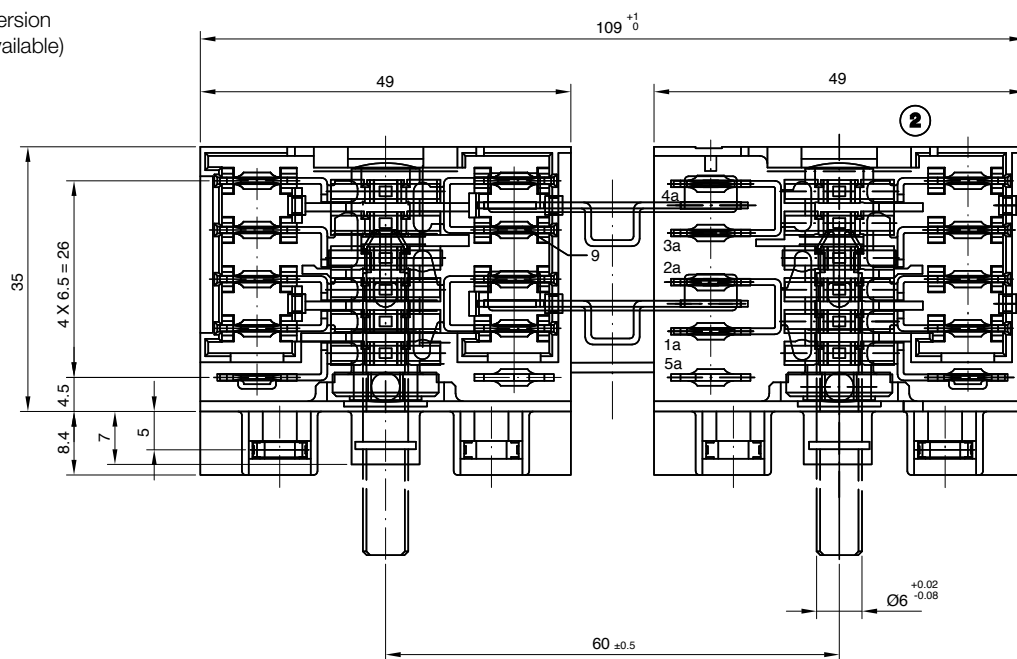

CONTACT SEQUENCE

Pos.	Ang.	P3		P1		P2		Pos.	Ang.	5a		1a-2a		3a-4a	
		S	1	1	2	3-3	4			S	1	2	3-3	4	
0	0°							0	0°						
1	51,4°	■	■	■		■	■	1	51,4°	■	■	■		■	■
2	102,8°	■		■		■	■	2	102,8°	■		■		■	■
3	154,2°	■		■		■	■	3	154,2°	■		■		■	
4	205,6°	■		■			■	4	205,6°	■		■			■
5	257,0°	■			■		■	5	257,0°	■			■		■
6	308,4°	■	■			■	■	6	308,4°	■	■			■	

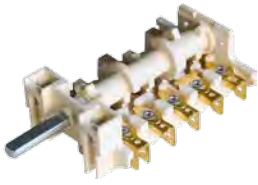

HT

TYPICAL APPLICATIONS	Electric hobs in freestanding cookers
WIRING DIAGRAMAS	2 standard positions rotary switch
GWFI	850 °C
GWIT	750 °C



7 positions rotary switch, ideal for electric hobs in freestanding cookers. M4 screw mounting and different shafts available. Special sequences with 4 - 5 - 6 positons are available.

- Terminals 6,3 mm
- M4 screw mounting
- Metal or plastic shafts
- With or without signal contact

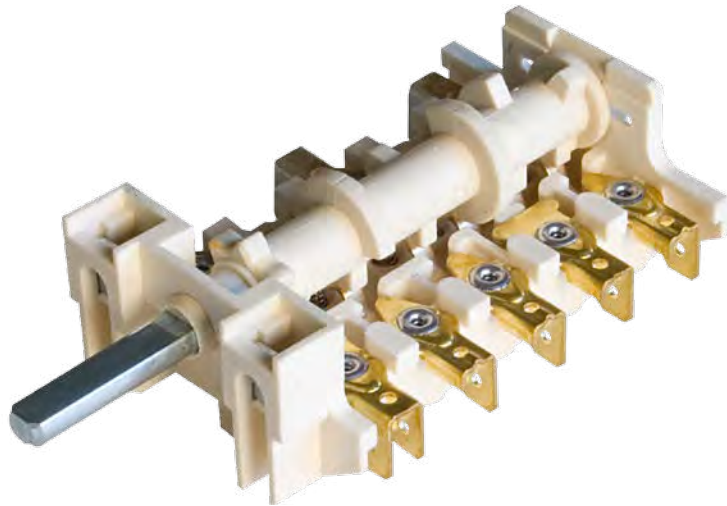

Rating
 12 A / 400 VAC - 30E3
 T150 °C
 According to
 EN61058-1 standard

16 (6) A / 250 VAC
 T150 °C
 According to
 UL 1054

OPTIONS

Metal or plastic shaft, with length on demand.

Metal shaft

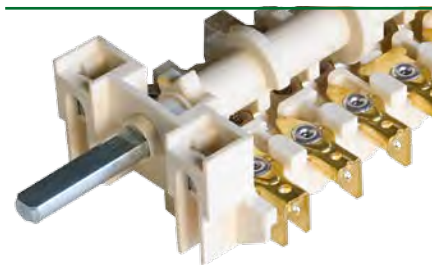

Plastic shaft

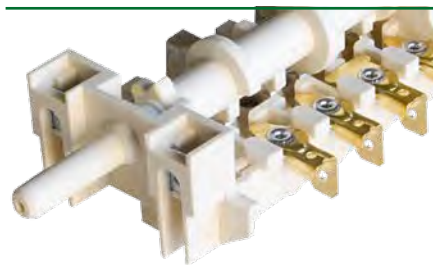

DIMENSIONS

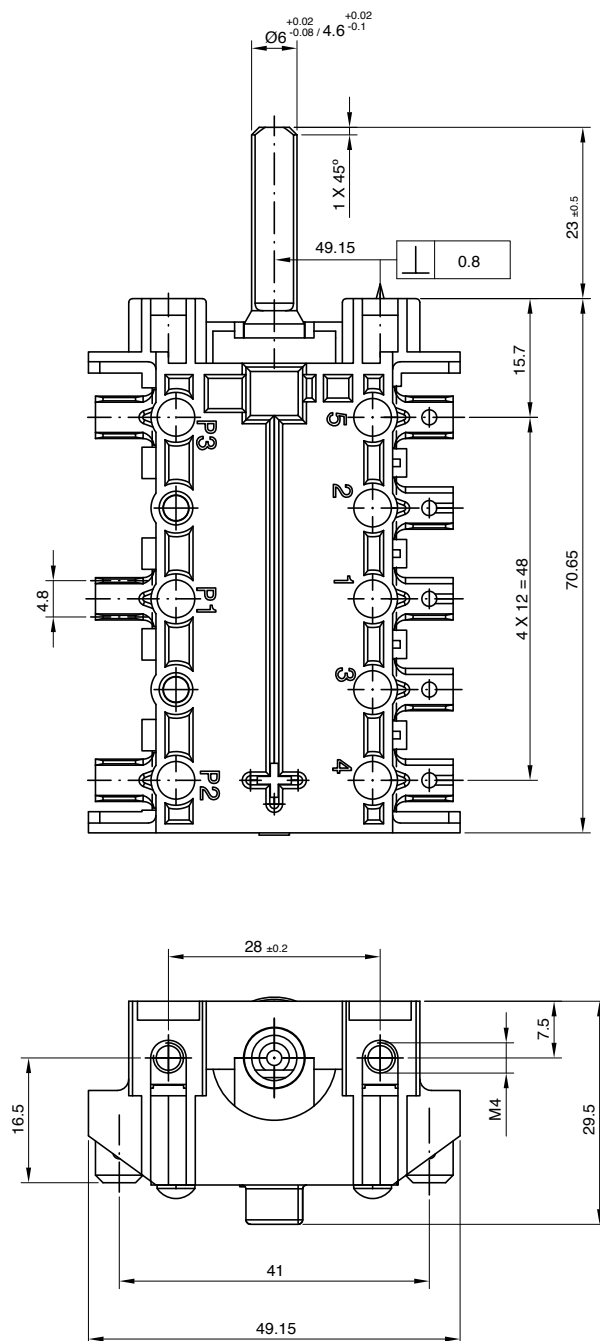

EXAMPLE OF CONTACT SEQUENCE

Pos.	Ang.	5	2	1	3-3	4
		P3		P1		P2
0	0°					
1	$51,4^\circ$	■	■	■		■
2	$102,8^\circ$	■	■			■
3	$154,2^\circ$	■	■			
4	$205,6^\circ$	■	■			■
5	$257,0^\circ$	■			■	■
6	$308,4^\circ$	■		■		■

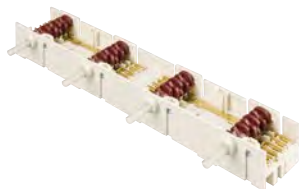

5HE 4 BLOCK

TYPICAL APPLICATIONS	Hobs control
WIRING DIAGRAMAS	7 positions
GWFI	850 °C
GWFI	750 °C



This solution integrates all wirings of four 5HE 7TAKT in a single body; robustness, compactness and easy mounting are its best features.

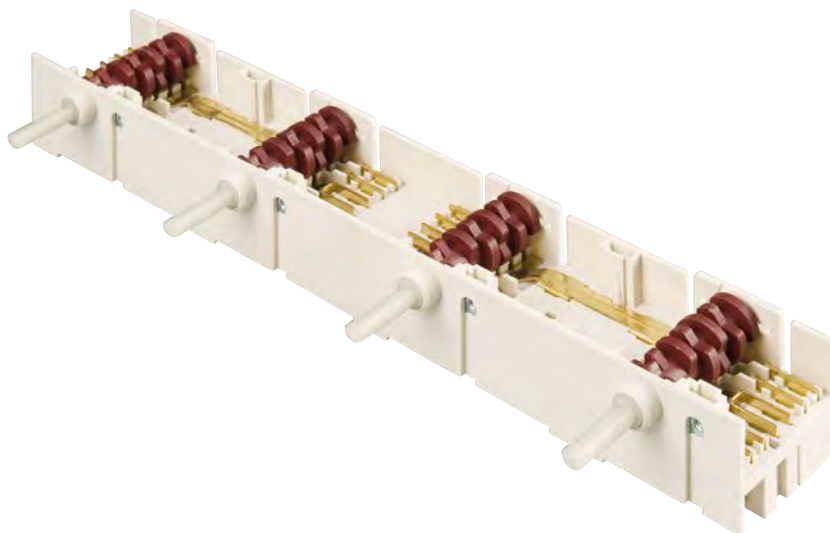

Rating
 12 A / 400 VAC - 30E3
 T150 °C
 According to
 EN61058-1 standard

16 A / 250 VAC
 T120 °C
 According to
 UL 1054

DIMENSIONS

2 versions:

L = 247.35
 D = 65 ±0.2

L = 230.45
 D = 60 ±0.2

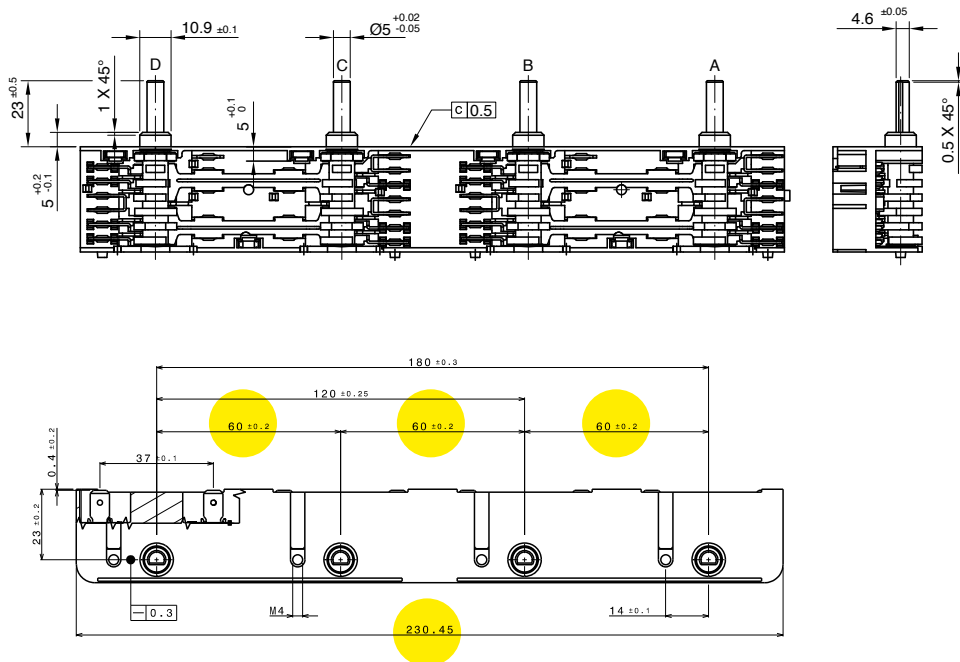



CH

TYPICAL APPLICATIONS	Function selector switch
WIRING DIAGRAMS	2 - 14 positions
CYCLE No.	Up to 30.000
AMBIENT TEMPERATURE	150 °C
GWFI	850 °C
GWFI	750 °C
ADDITIONAL FEATURES	<ul style="list-style-type: none"> ■ M4 screw mounting ■ 26 contacts version available



Thermostat version available

16 (6) A / 250 VAC - 30E3
 16 (8) A / 250-125 VAC - 10E3
 18 A / 250-125 VAC - 30E3
 12 A / 400 VAC - 30E3
 T150 °C
 According to
 EN61058-1 standard

3/4 HP / 125 VAC
 18A / 250 VAC
 16A / 250 VAC
 T125 °C
 According to
 UL 1054

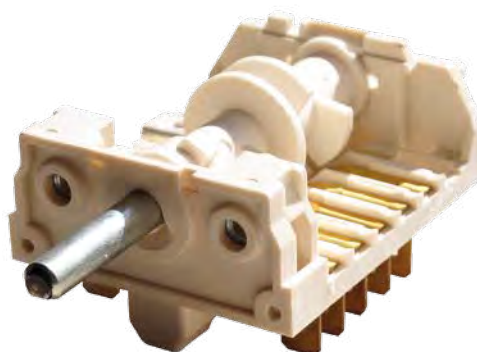

DIMENSIONS

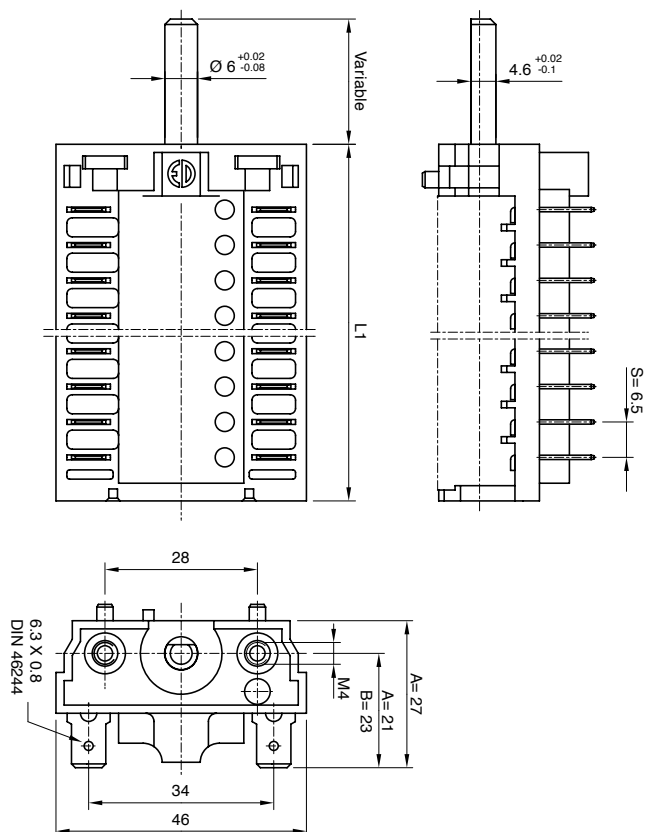

CONTACT SEQUENCE

Basic Version					
Type	Contacts		L1		Version
	16(4)/250ac 6(2)/250ac	6(1.5)/250ac	S=7	S=6.5	
1-CH	1		29,5*		A
2-CH	2		25	36*	A
3-CH	3		32	33	A
4-CH	4		39	39.5	A, B
5-CH	5		46	46	A
6-CH	6		49,5		A
6-CH	6		53	52.5	A, B
7-CH	7			59	A, B
8-CH	8		67	65.5	A, B
9-CH	9			72	A
10-CH	10		81	78.5	A, B
11-CH	11		88	85	A, B
12-CH	12		95		A
13-CH	8	5	S=7	S=6	A
			97		

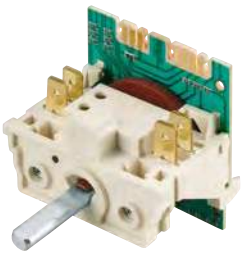

2CH with encoder

TYPICAL APPLICATIONS Electronic and electrical function selector

WIRING DIAGRAMS ■ On demand

CYCLE No. 30.000

AMBIENT TEMPERATURE 85 °C

ADDITIONAL FEATURES ■ Solution combining selector and encoder functions, that allows to improve flexibility and compactness



Solution combining selector and encoder functions, that allows to improve flexibility and compactness.

Rating

16 (6) A / 250 VAC

10 (2) A / 400 VAC

18 A / 250 VAC

6 (4) A / 250 VAC

T 150 °C

According to

EN61058-1 standard

3/4 HP / 125 VAC

16 A / 250 VAC

13.8 A / 250 VAC

T 85 °C

According to

UL 1054

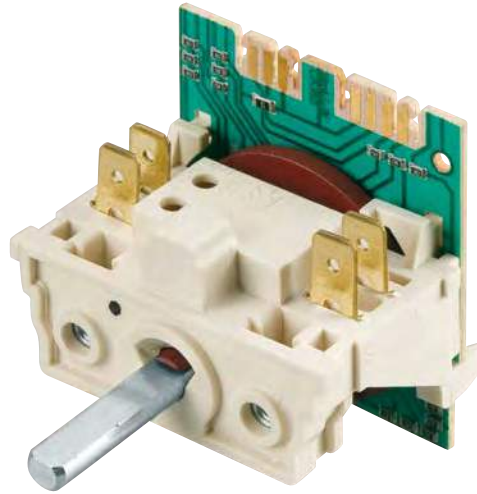

DIMENSIONS

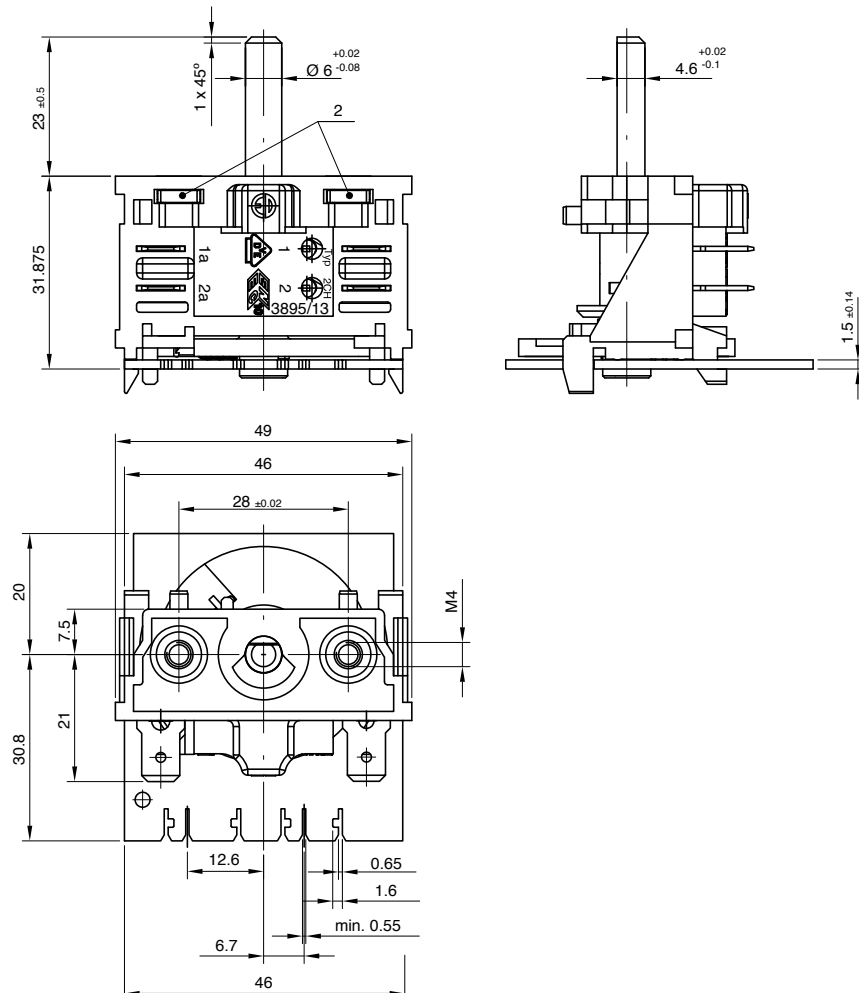

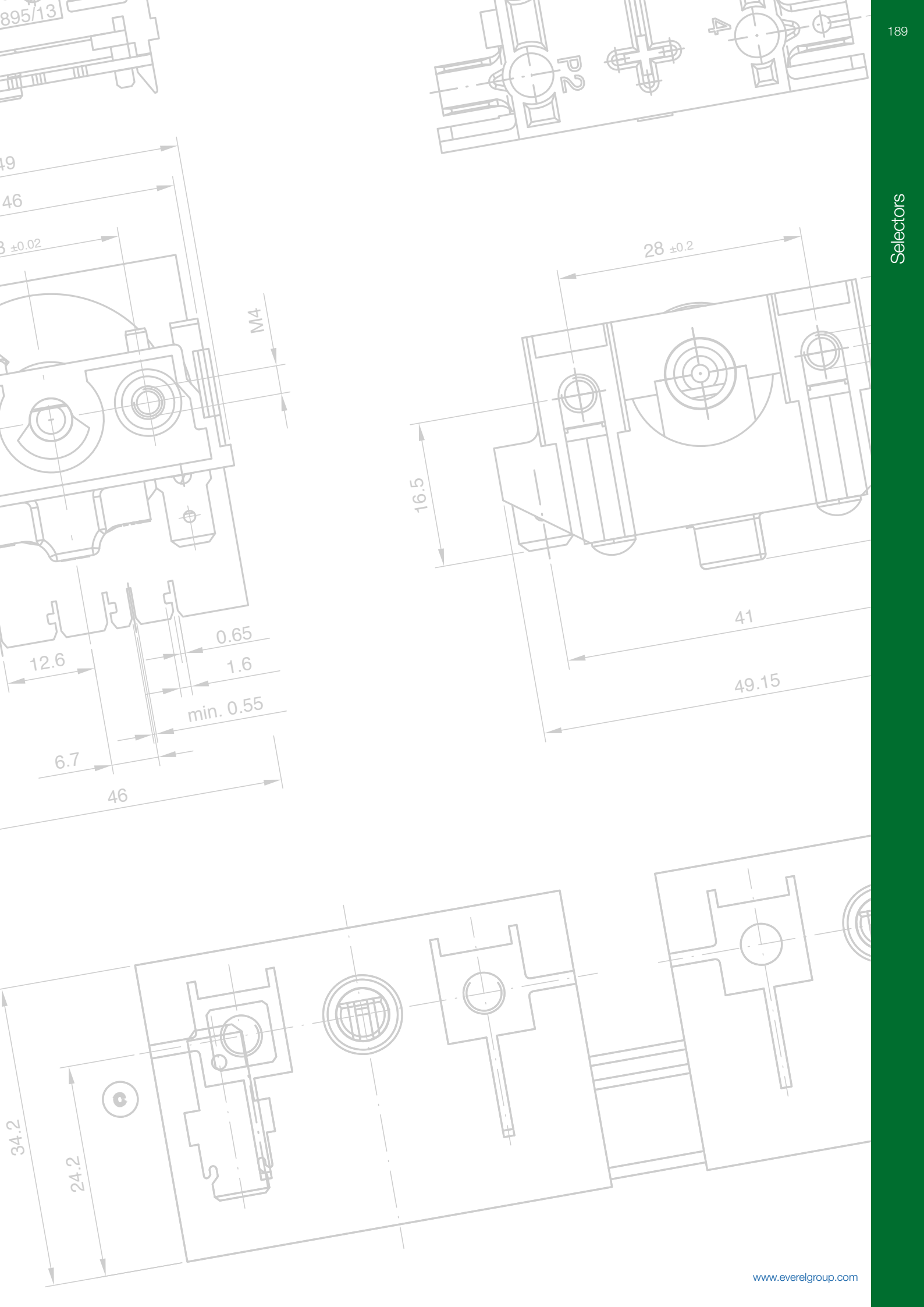

Codi

04



CS

193



CV

194

CODI



TYPICAL APPLICATIONS	Electronic function selector Washing machines and dishwashers
WIRING DIAGRAMAS	<ul style="list-style-type: none"> ■ 4-bit digital output ■ Up to 32 positions ■ BCD, Gray Code and resistor array selection
CYCLE NR	10.000
AMBIENT TEMPERATURE	85 °C

Designed with the special demands of today's electronic control applications in mind. Everel encoders provide an outstanding array of potential solutions.

Rating

20 mA / 5 VDC
T 85 °C

ADDITIONAL FEATURES

- Golden contacts
- 360° with or without end stop
- Permitted angular tolerance: +/-2°
- 10.000 cycles
- Operating torque: custom
- Different connecting systems
- Different mounting solutions available, such as snap-in, twist-lock or screws
- Coupling with function selector switches

SOLUTIONS



Screw mounting CODI

The encoder can be fixed to panel with a screw or a nut.

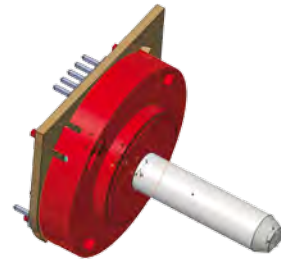

Pin strip connector CODI

It allows to weld the encoder directly on the circuit board of the customer product without wiring.



M4 screw mounting CODI

The encoder can be fixed on the panel by two M4 screws.

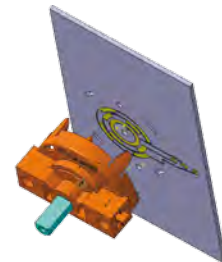

Version without PCB for mounting on PCB

Everel can also supply only the electromechanical part of the encoder allowing the customer to define the board circuit.

CS

CS1



CODI	FIXING TYPE	H SHAFT (mm)	NUMBER OF POSITIONS
CS	Snap-in	■ 22,5	■ 16 P

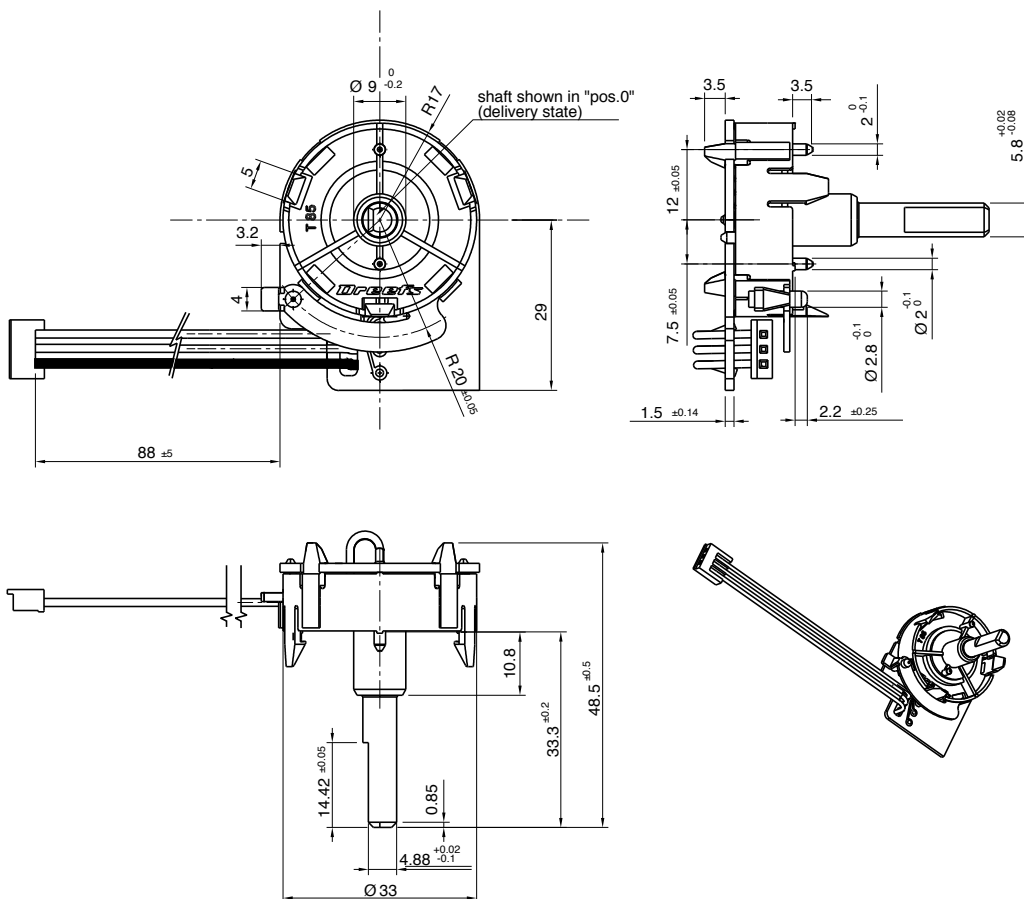

MF encoder, standard body version with snap in fixing type or self snapping fixing type.

CS2

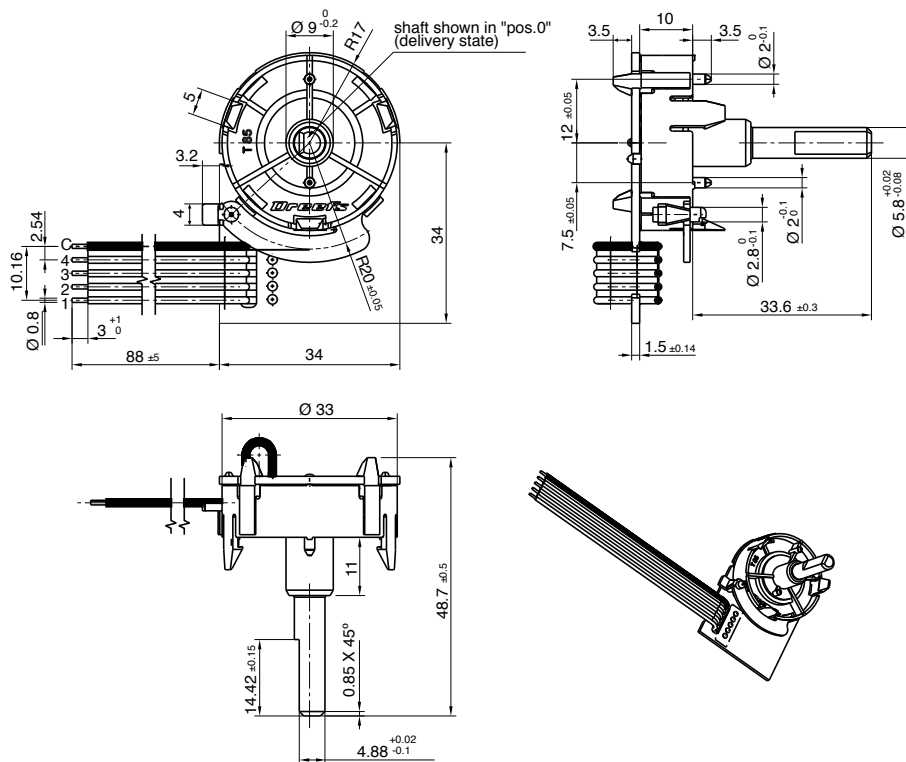

MF encoder, standard body version with snap in fixing type or self snapping fixing type.

CV

CV1



CODI	FIXING TYPE	H SHAFT (mm)	NUMBER OF POSITIONS
CS	Threaded ring	■ 9,7	■ 6 P + 180° free rotation

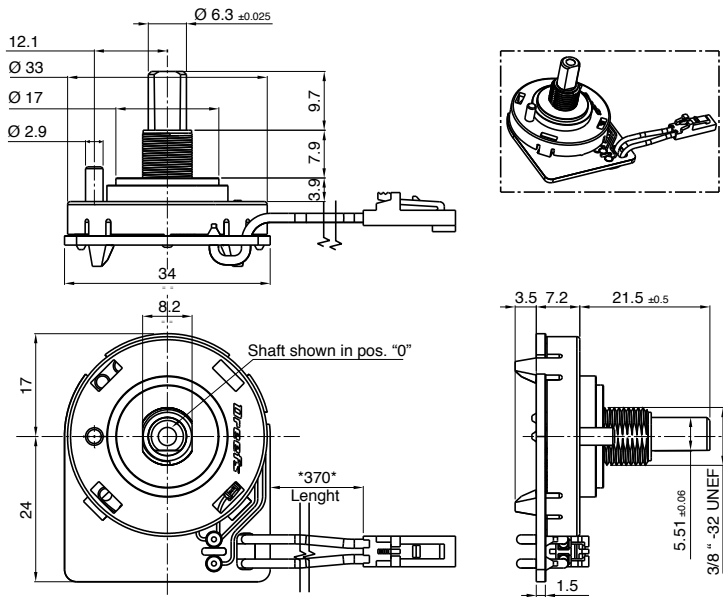

MF encoder, standard body version with snap in fixing type.

CV2

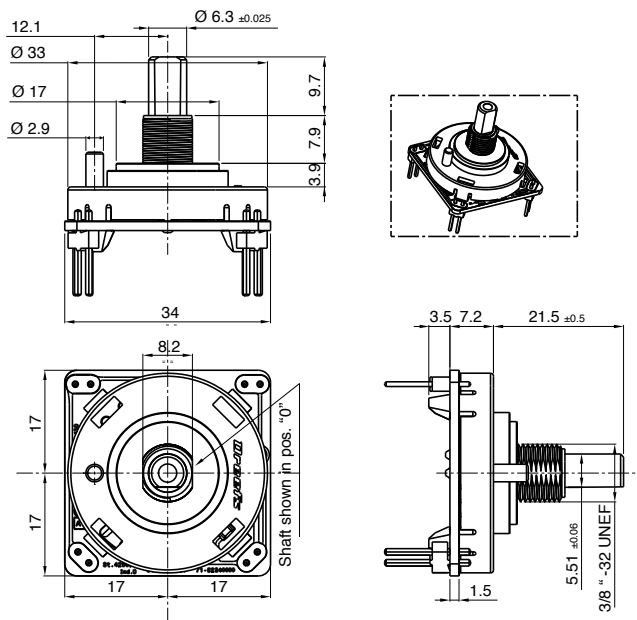

MF encoder, standard body version with snap in fixing type.

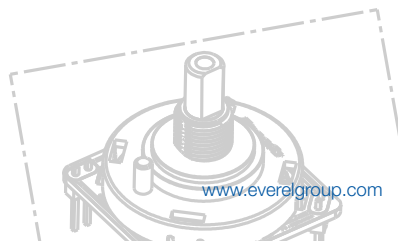
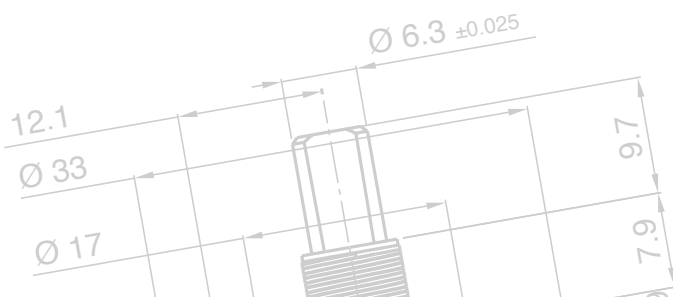
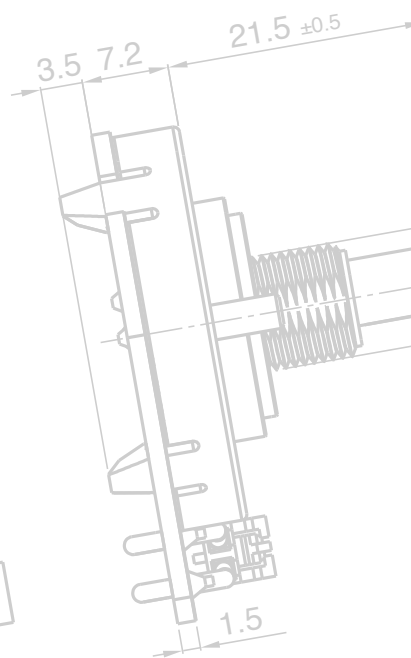
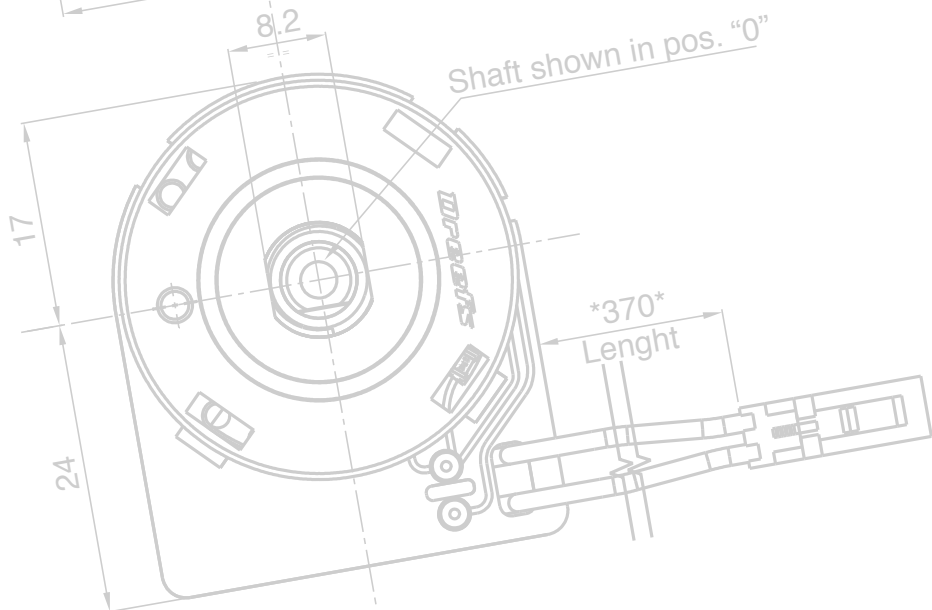
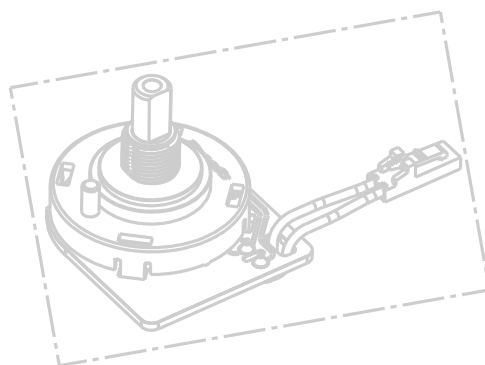
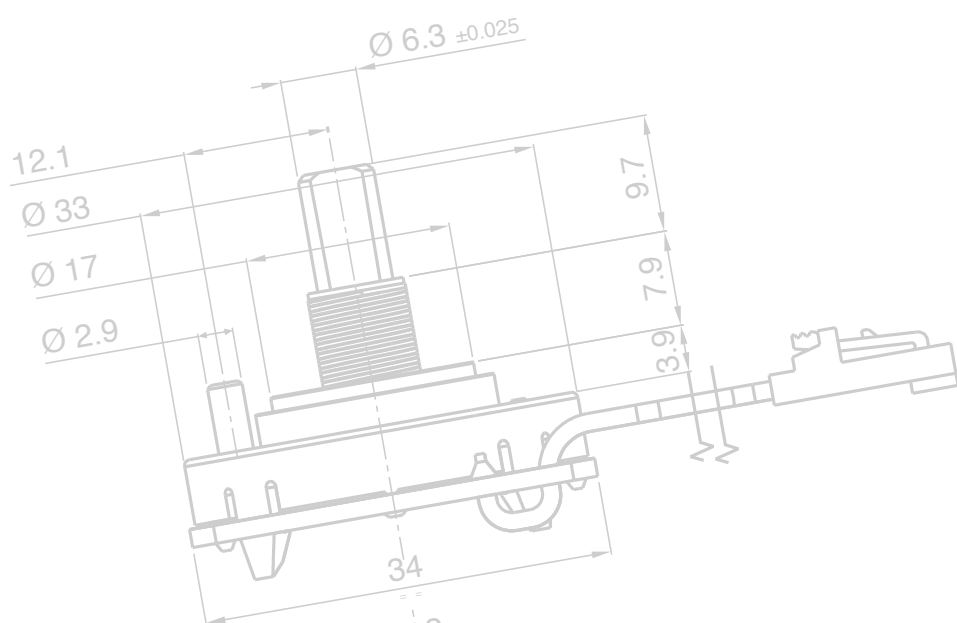
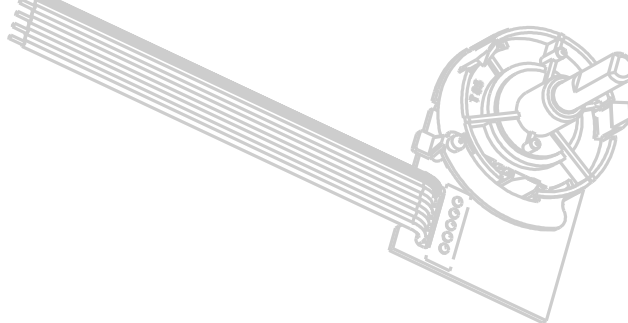
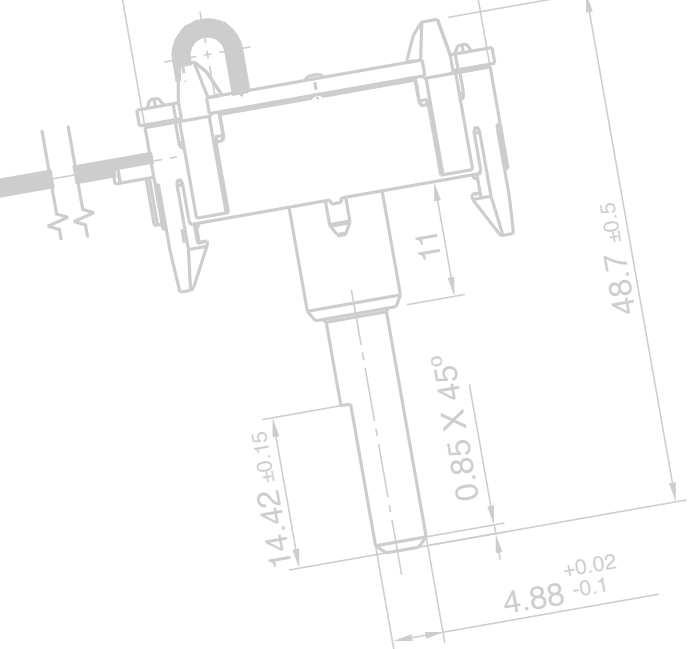

Minicodi

04



MS

199



MF

200

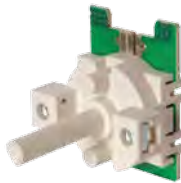

MB

200



MV

201



MK

202

MINICODI



TYPICAL APPLICATIONS	Electronic control for appliances
WIRING DIAGRAMAS	<ul style="list-style-type: none"> ■ 2-bit digital output (incremental function) ■ Up to 21 positions
CYCLE NR	10.000
AMBIENT TEMPERATURE	85 °C

Encoders display different dimensions and mounting systems on the control panel. Dimensions vary a lot depending on the different applications. MINICODI series as potentiometer can be coupled with selector switches.

ADDITIONAL FEATURES

- Golden contacts
- 360° with or without end stop
- Different mounting solutions available:
snap-in or M4 screws or self tapping screws
- Push to select version available
- Coupling with function selector switches
- Miniature encoder
- 2-bit digital output (incremental function)
- Typical use for analogical / resistive applications
- Permitted angular tolerance: +/- 2°
- End stops: ≥ 100 Ncm
- Operating torque: custom
- Edge connectors

Rating
20 mA / 5 VDC
T 85 °C

MINICODI - INCREMENTAL ENCODER

The mechanical encoder with digital output are available in absolute or incremental code. The shaft rotation, in the incremental output, generates pulses that, sent to the microprocessor, determine a "relative" position. The counts of pulses continue with the rotation of the shaft, which allows the position to change infinitely, or as the microprocessor allow. Direction may be determined by analyzing difference between the two channels.

Example of incremental encoder configuration with gray code

Detent	Ang.	Output	
		C	1 2
1	0°	■	■
2	30°	■	■ ■
3	60°	■	■
4	90°	■	
5	120°	■	■
6	150°	■	■ ■
7	180°	■	■
8	210°	■	
9	240°	■	■
10	270°	■	■ ■
11	300°	■	■
12	330°	■	

Example of incremental encoder obtained with momentary positions

Pos.	Ang.	Output	
		1	2
1 momentary	+30°	■	
0 stable	0		
2 momentary	-30°		■

MINICODI - POTENTIOMETER

The potentiometer is a mechanical encoder with resistive analogical output. The potentiometer version can be implemented either using a continuous “carbon” layer or a resistor array. The potentiometer has a rotation that can be infinite or steps (positions). Push to select function available.

Potentiometer resistor array

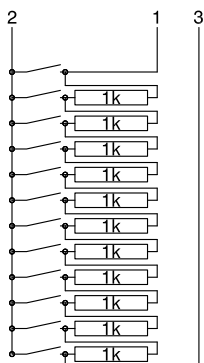

Pos.	Ang.	2	
		1	3
1	0°	10K	11K
2	30°	1	10K
3	60°	2K	9K
4	90°	3K	8K
5	120°	4K	7K
6	150°	5K	6K
7	180°	6K	5K
8	210°	7K	4K
9	240°	8K	3K
10	270°	9K	2K
11	300°	10K	1K
12	330°	11K	10

Potentiometer carbon film

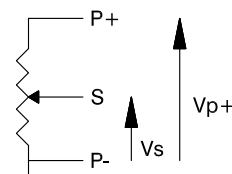

Value between P- and S		
Detent	Ang.	Output voltage %
1	0°	0%
2	35°	11%
3	70°	22%
4	105°	33%
5	140°	44%
6	175°	56%
7	210°	67%
8	245°	78%
9	280°	89%
10	315°	100%

endstop

MS

MINICODI	FIXING TYPE	H SHAFT (mm)	NUMBER OF POSITIONS
MS1	Screw m4	<ul style="list-style-type: none"> ■ 11 ■ 13 	<ul style="list-style-type: none"> ■ Free rotation 360° ■ Free rotation with mechanical stop
MS2	Self tapping screw	<ul style="list-style-type: none"> ■ 16 ■ 18 ■ 20,4 ■ 23 	<ul style="list-style-type: none"> ■ Positions number: min. 2 - max 21 with or without mechanical stop ■ Double momentary

MS1



MS1

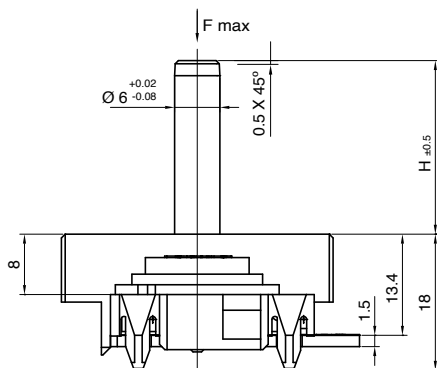

MS2

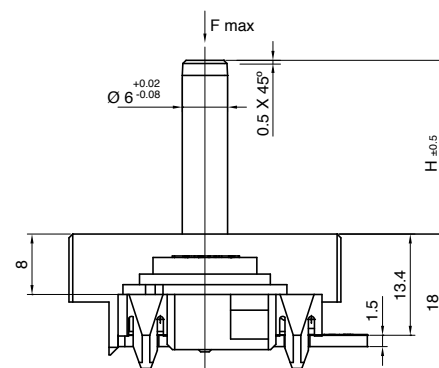

MS2

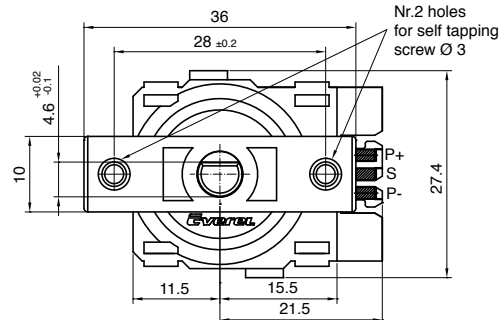
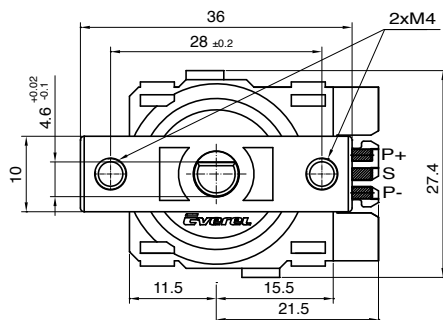

MS1 encoder, body standard version with M4 screw fixing type.

MS2 encoder, body standard version with self tapping screw fixing type.

MF

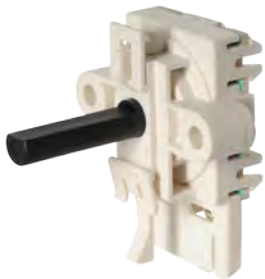

MINICODI	FIXING TYPE	H SHAFT (mm)	NUMBER OF POSITIONS
MF	<ul style="list-style-type: none"> ■ Self tapping screw ■ Snap in 	<ul style="list-style-type: none"> ■ 23 	<ul style="list-style-type: none"> ■ 3 P ■ 6 P ■ 8 P ■ 10 P ■ 12 P

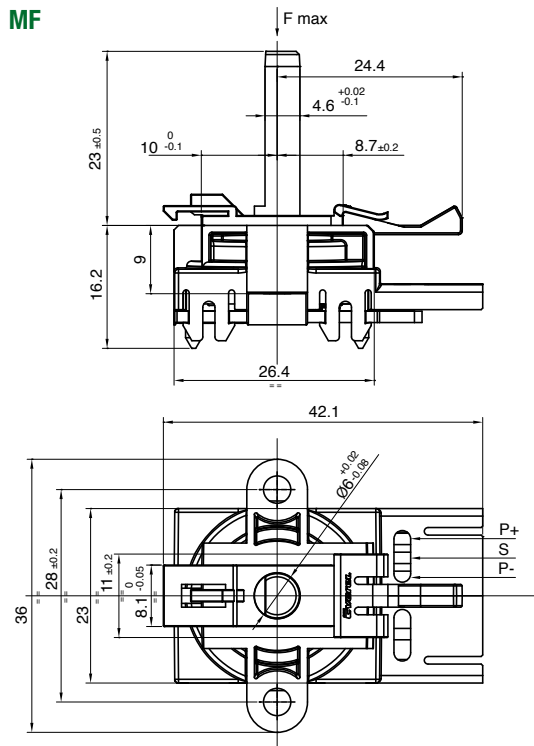

MF encoder, version with snap in fixing type or self tapping fixing type.

MB

MINICODI	FIXING TYPE	H SHAFT (mm)	NUMBER OF POSITIONS
MB1	Screw m4	<ul style="list-style-type: none"> ■ 13,7 cross ■ 23 	<ul style="list-style-type: none"> ■ Free rotation with 1 position at 0° ■ Free rotation with 20 positions
MB2	Snap in		

MB1

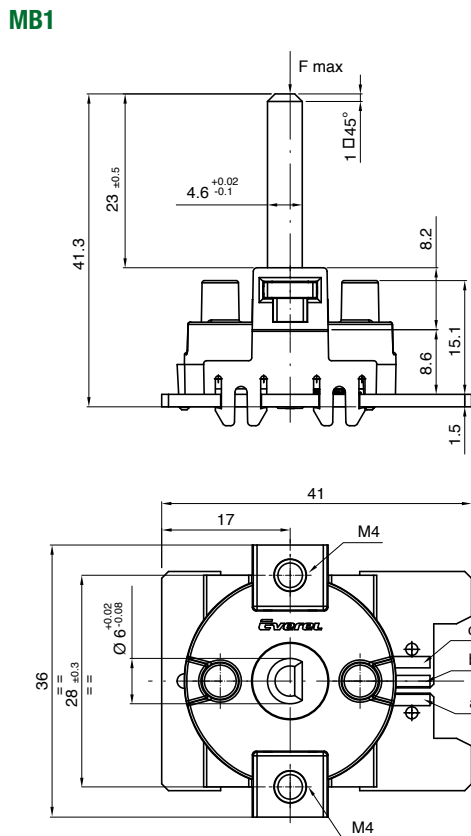
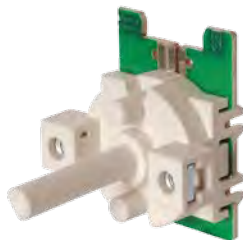

MB1 encoder, version with M4 screw fixing type.

MB2

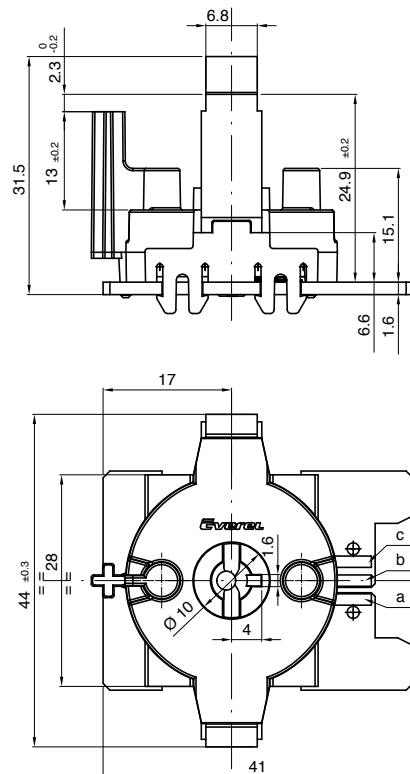

MB2 encoder, version with snap in fixing type.

MB2

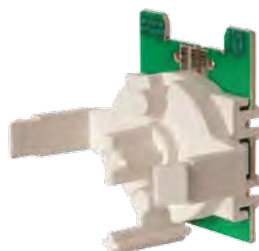

MV

MINICODI	FIXING TYPE	H SHAFT (mm)	NUMBER OF POSITIONS
MV1	Threaded ring	■ 12,7	■ Free rotation 360° with stop
MV2	Soldering pin		

MV1

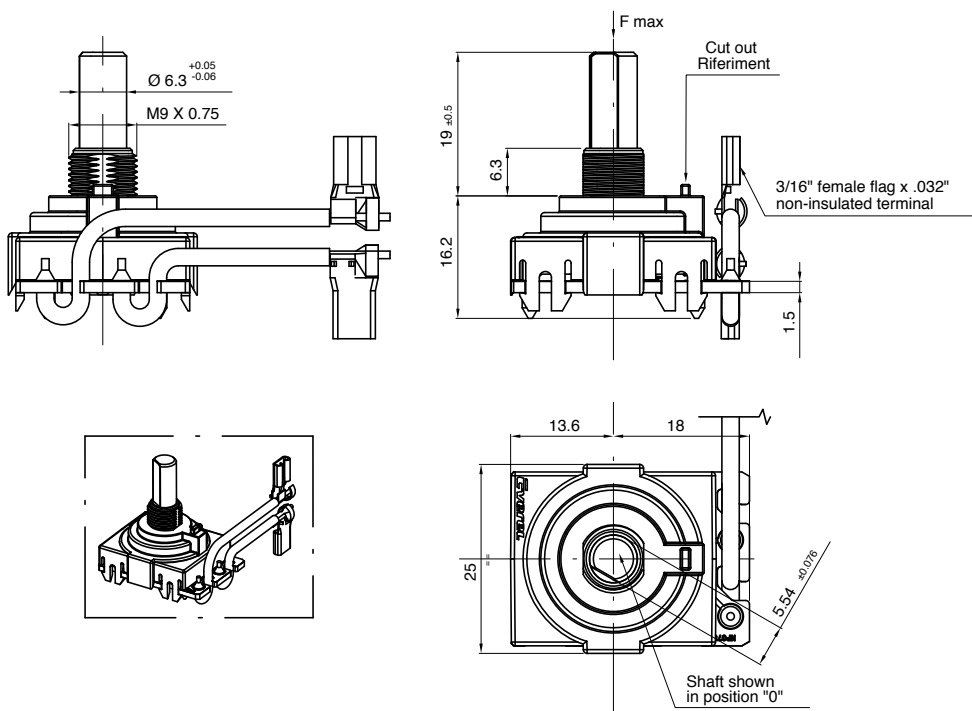

MV2

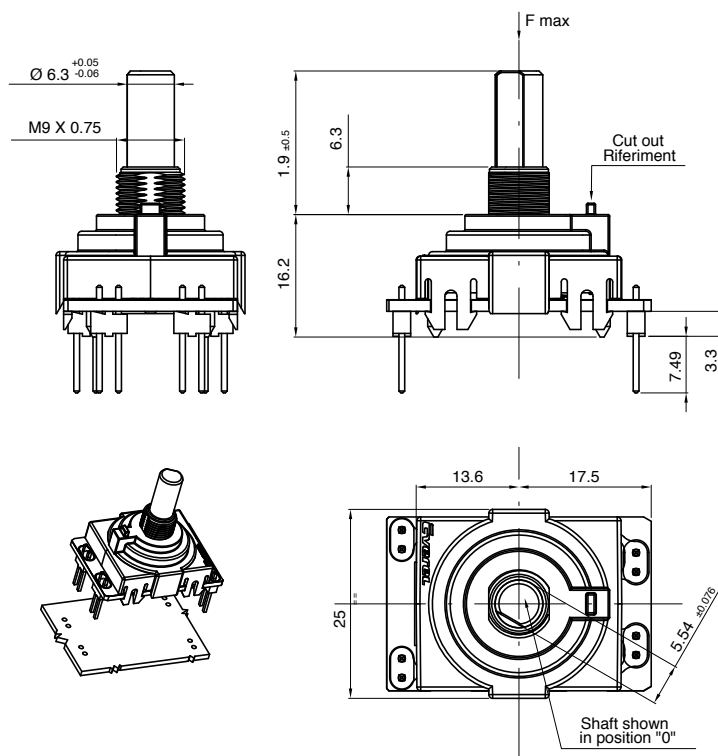



MINICODI	FIXING TYPE	H SHAFT (mm)	NUMBER OF POSITIONS
MK1	Screw m4	<ul style="list-style-type: none"> ■ 13 ■ 18,7 	<ul style="list-style-type: none"> ■ 21 positions free rotation ■ 20 positions free rotation
MK2	Self tapping screw	<ul style="list-style-type: none"> ■ 23 ■ 24 	<ul style="list-style-type: none"> ■ Double momentary

SHAFT

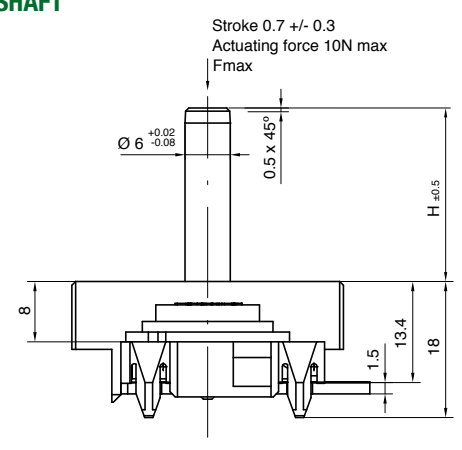

PUSH TO SELECT

The push to select accessory is used to select a scroll menu function and to confirm the selected value (i.e. temperature).

MK1



MK1

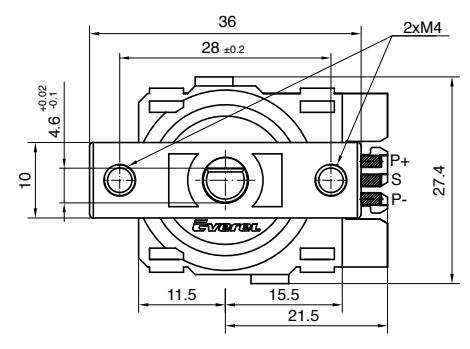

MK1 encoder, version with M4 screw fixing type.

MK2

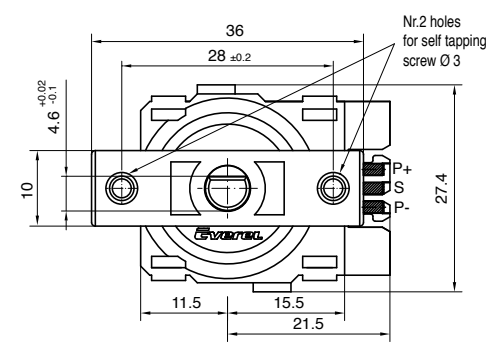

MK2 encoder, version with self tapping screw fixing type.

MK2



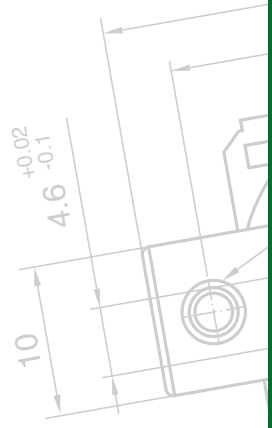
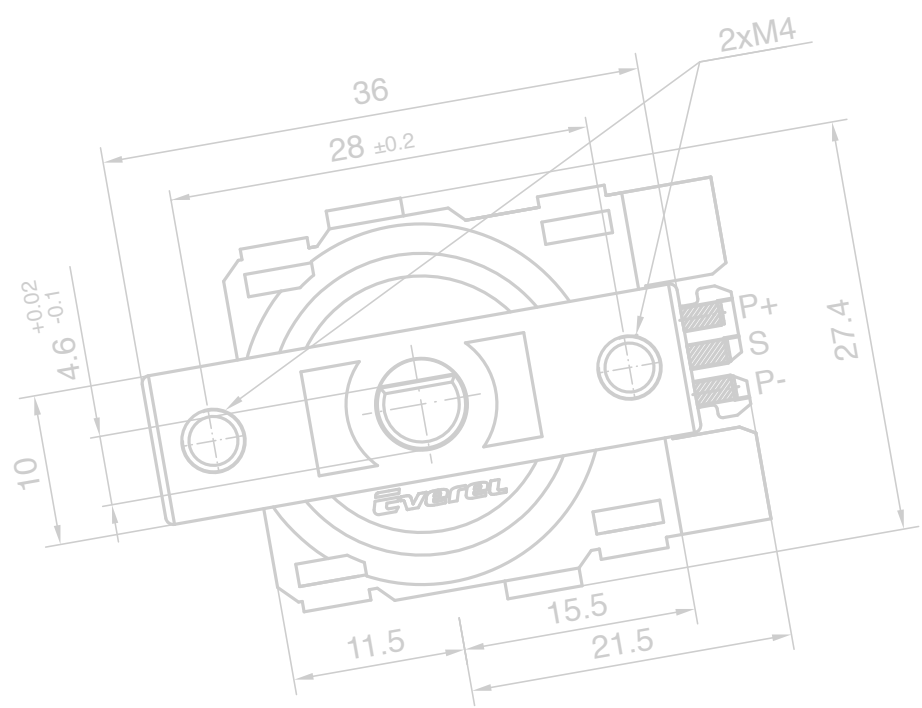
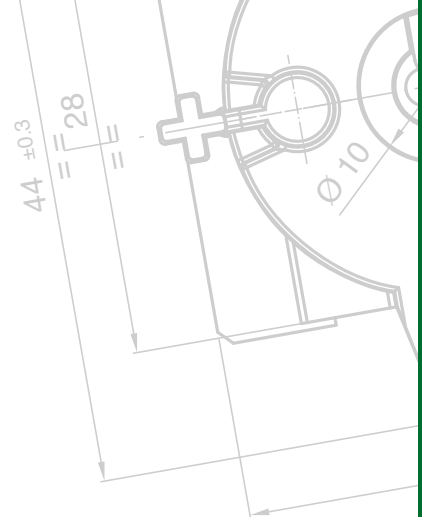
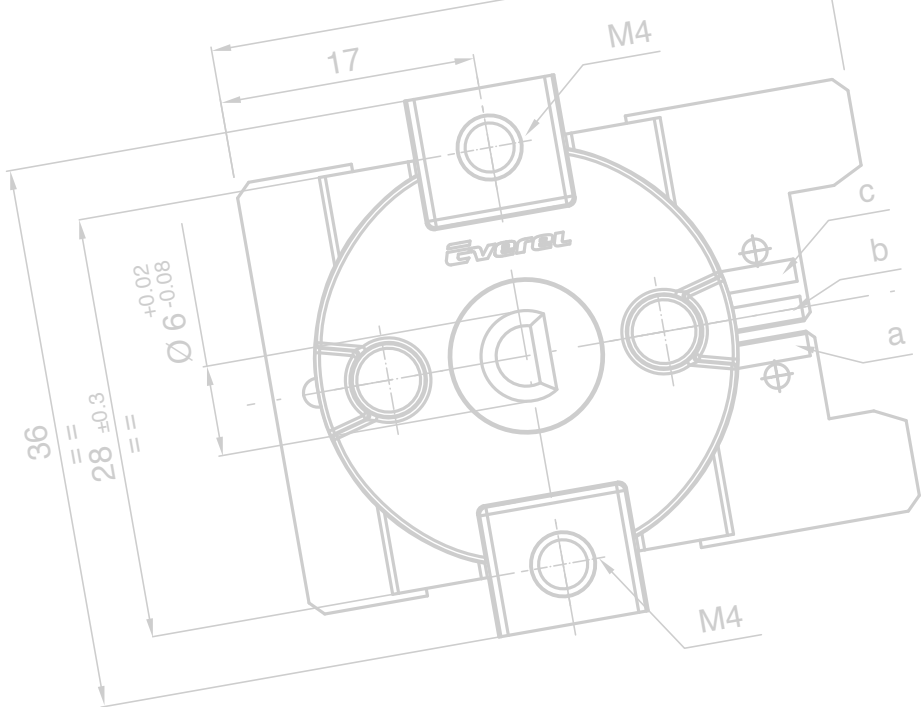

F max

Cut out Riferiment

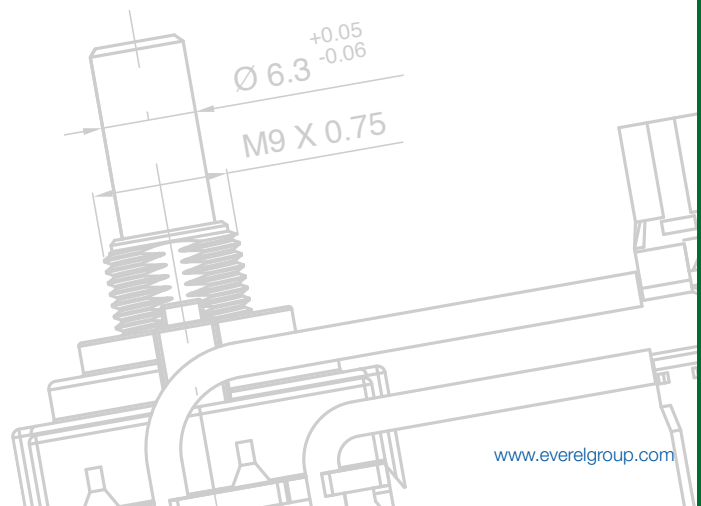

Motors

05



**Shaded Pole
Motor Ø 52**

206

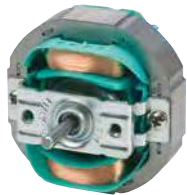

**Shaded Pole
Motor Ø 58**

208



**Fans
and Accessories**

210



EC Brushless Motor

212



SHADED POLE MOTOR Ø 52

FEATURES
Motor life: from 3.000 hours (sinterized sleeve bearings) to 30.000 hours (ball bearings)
Heat and fire resistance version available GWIT 775 °C
2-speed version available
Class of insulation according to IEC 60085: F or H
Power supply: from 12 VAC to 240 VAC / 1 / 50-60 Hz



Ideal for reduced space, they are available in a wide range of versions and they are featuring high electromagnetic efficiency. This allows Giem to meet several application requirements: ventilators, fan heaters, air cleaners, and humidifiers

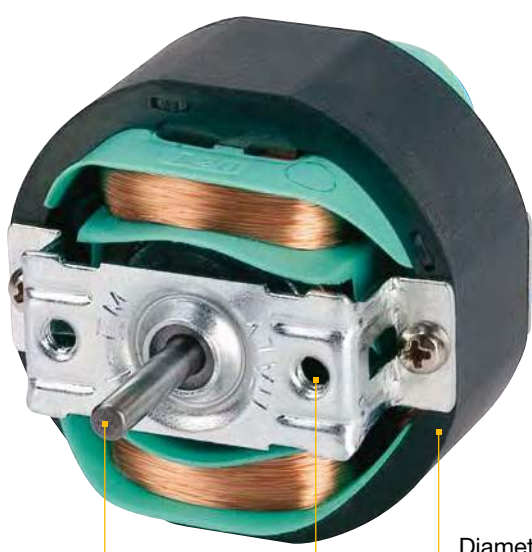

Shaft diameter 4 mm;
clock-wise and counter clock-wise

Fixing holes threaded M4

Diameter: 52 mm

OPTIONS



Shaft can be smooth, milled or with grooves with length on demand



Brass bearings or ball bearings



Stack height from 16 to 30 mm



Fuse



Thermostat

Motors protected by motor impedance or thermal protected by fuse or thermostat (autoreset or self holding)

DIMENSIONS

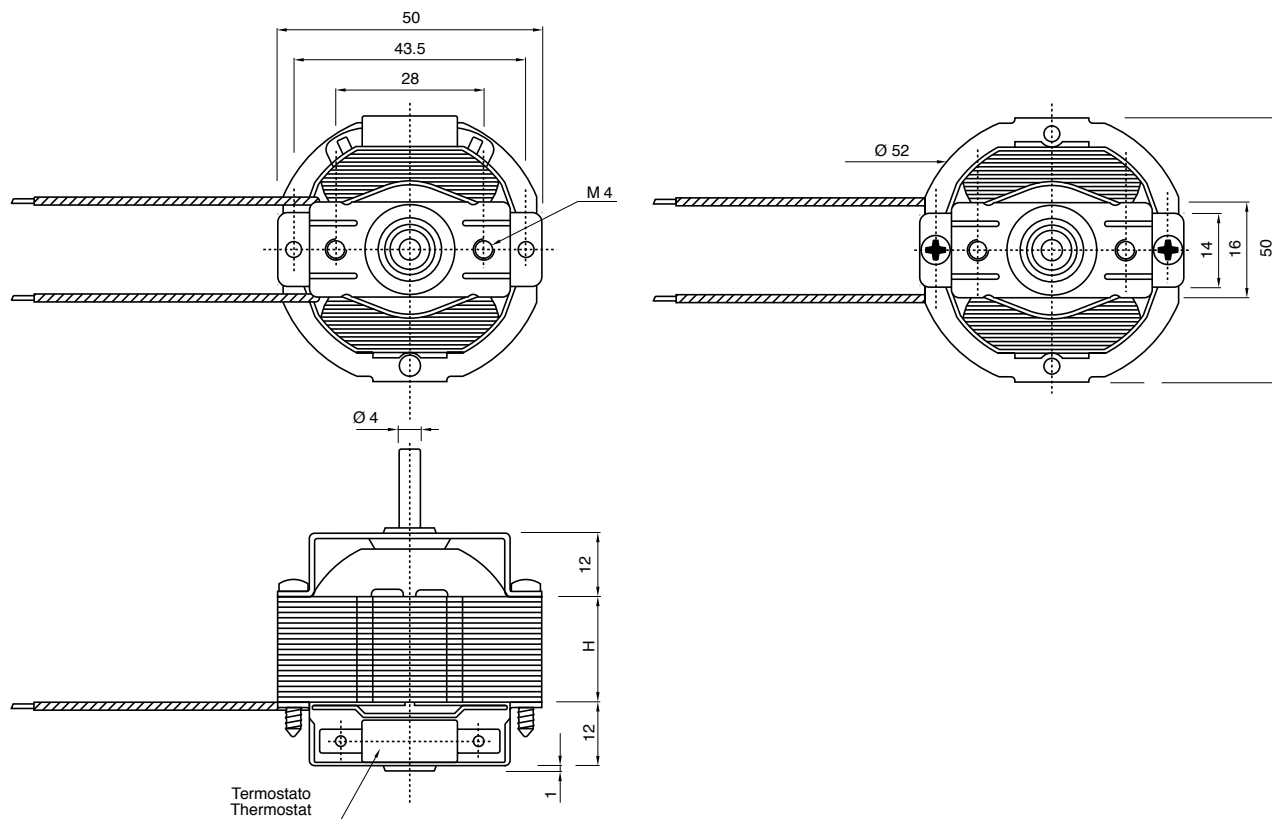

CUT OUT

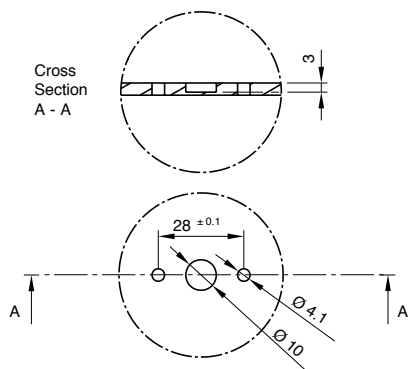

TECHNICAL FEATURES

Stack height (H) mm	Power absorption W		
	Low consumption version	Normal version	Powered version
16	8	15	25
20	10	20	25
25	15	20	30
30	20	30	40

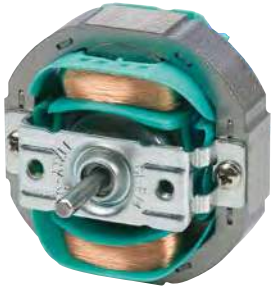

SHADED POLE MOTOR Ø 58

FEATURES
Motor life: from 3.000 hours (sinterized sleeve bearings) to 30.000 hours (ball bearings)
Heat and fire resistance version available GWIT 775 °C
2-speed version available
Class of insulation according to IEC 60085: F or H
Power supply: from 12 VAC to 240 VAC / 1 / 50-60 Hz



on demand

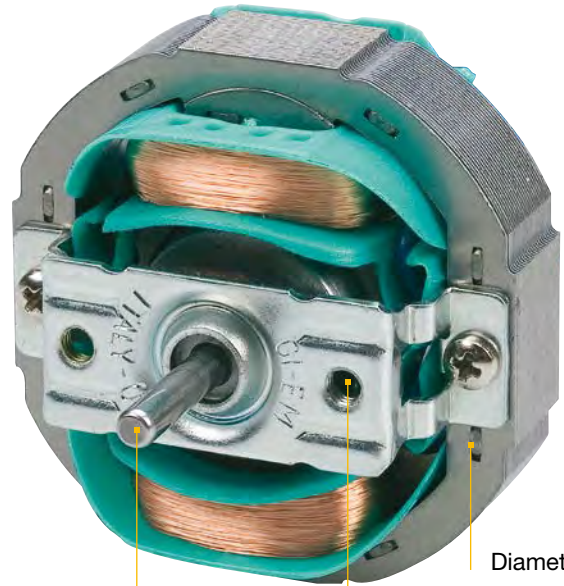

Shaft diameter 4 mm;
clock-wise and counter clock-wise

Diameter: 58 mm
Fixing holes threaded M4

OPTIONS



Shaft can be smooth, milled or with grooves with length on demand



Brass bearings or ball bearings



Stack height from 12 to 35 mm

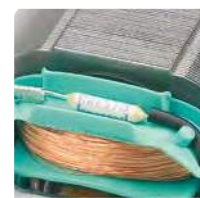

Fuse

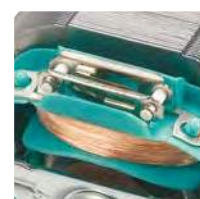

Thermostat

Motors protected by motor impedance or thermal protected by fuse or thermostat (autoreset or self holding)

DIMENSIONS

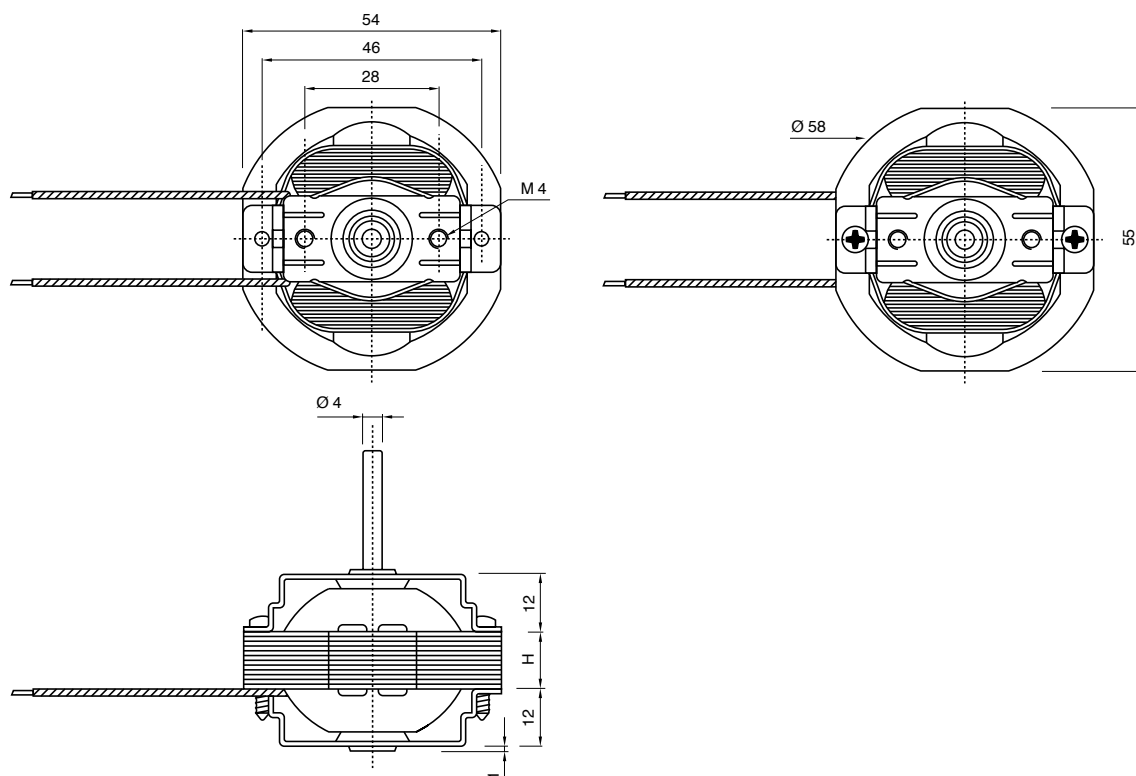

CUT OUT

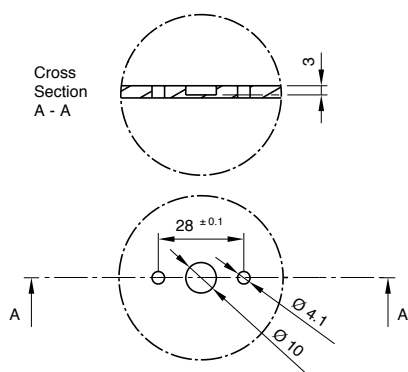

TECHNICAL FEATURES

Stack height (H) mm	Power absorption W		
	Low consumption version	Normal version	Powered version
12	8	15	25
16	10	20	30
20	15	25	30
25	15	25	35
30	20	30	40
35	20	35	50

FANS AND ACCESSORIES

AVAILABLE FOR SHADED POLE MOTORS Ø 52 AND Ø 58

FEATURES

Wide offer of fans, with different colours, materials and dimensions for motors Ø 58 and Ø 52

Forcing and suction version

Nylon or aluminum

Snap-in mounting without tools on Ø 4 mm shaft



PLASTIC 7-BLADES FAN

Material: Nylon
Colour: Black
Diameter: 130 mm

Code

GM1VN01A00

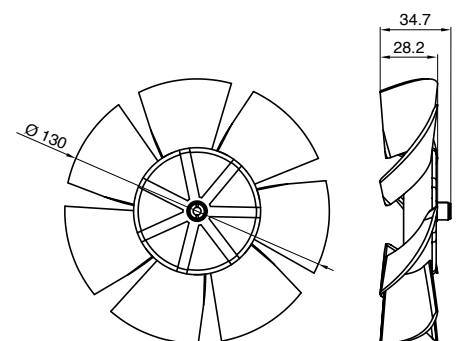

METAL 5-BLADES FAN

Material: Aluminum
Colour: Glossy
Diameter: 130 mm

Code

GMVKW52002

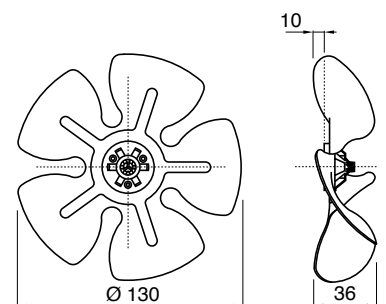



METAL 3-BLADES FAN

Material: Iron sheet
 Colour: Black
 Diameter: 156 mm

Code

GMVTR51004

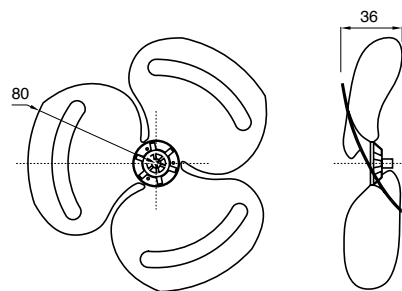

METAL 2-BLADES FAN

Material: Plastic, aluminum
 Colour: Black
 Diameter: 158 mm

Code

GMVCD51001

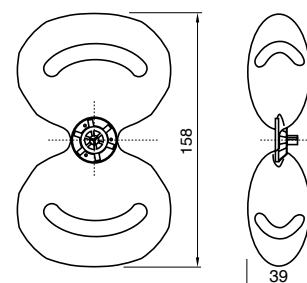

CENTRIFUGAL PLASTIC FAN

Material: Nylon
 Colour: Black
 Diameter: 84 mm
 Height: 46 mm / 67 mm

Code (h. 46)

GMVDD00010

Code (h. 67)

GMVXX03020

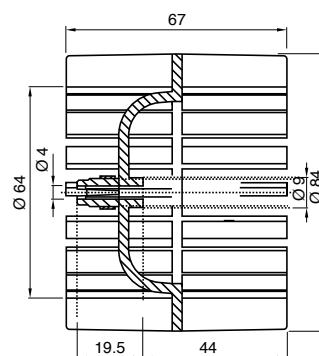
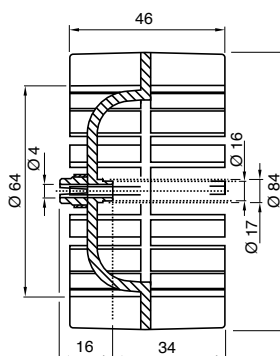
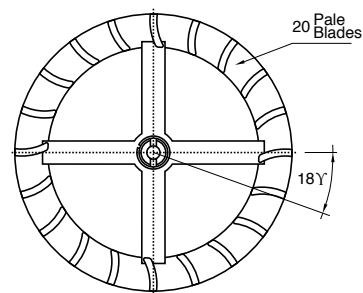

EC BRUSHLESS MOTOR



**EXTREMELY SILENT
LOW ENERGY CONSUMPTION
HIGH PERFORMANCE**

Example for Performance EC motor stack height 12 mm.

RATED VOLTAGE	230 VAC (-15%; +10%)
INSULATION CLASS	F
RATED MECHANICAL POWER	1,2 W
RATED ELECTRIC POWER	6,7 W
MOTOR EFFICIENCY	18%
WITHSTAND VOLTAGE	1800 V
TORQUE DIRECTION	CW
NUMBER OF POLES	2
DRIVE	Half bridge
MAX SPEED	3.000 rpm
PROTECTION	Thermostat 100 °C
OPERATING TEMPERATURE	-5 °C / +40 °C
NOTE	Shaft lenght: on request Wires color: on request

Everel has released the Performance and Performance Plus EC brushless motors series. The Performance Plus version, which integrates more advanced electronics, allows the control of motor speed and the possibility of reversing the rotation; humidity sensor, presence sensor, and timer can be integrated in the same board; motor efficiency up to 40%.

- Energy saving: up to 70% compared to traditional motor
- Integrated electronic
- Power supply from 12 VAC to 240 VAC / 1 / 50-60. Also available 12 VDC
- Same dimensions and cut-out of standard motors (diameter 58 mm)
- Performance Plus version: humidity sensor, presence sensor, timer, lighting mgmt, firmware customization
- Ball bearings



OPTIONALS



Shaft can be smooth, milled or with grooves with length on demand



Stack height from 12 to 35 mm

Fuse



Motors protected by thermal fuse or thermostat (autoreset or self holding)

Thermostat



DRAWING

(Performance version)

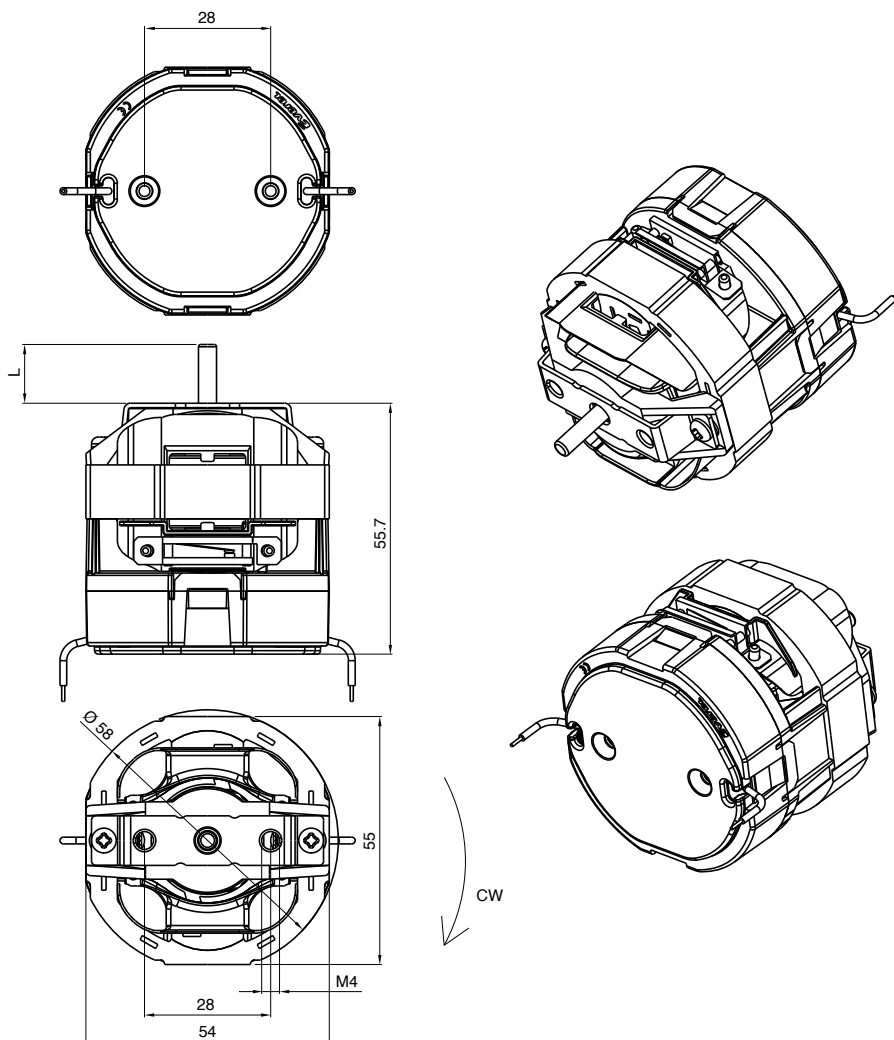

Different covers available

TECHNICAL FEATURES

PERFORMANCE



Integrated electronic and power supply board

Installation from electronic side available

PERFORMANCE PLUS



Timer management

Humidity sensor connector
Speed control
Presence sensor connection

SELV version 12 V available

SELV: Safety Extra Low Voltage

Stack height (H) mm	Power absorption W	Shaft Power W
12	4,5 ... 15	0,8 ... 2,7
16	6,5 ... 20	1,2 ... 3,6
20	7,5 ... 25	1,4 ... 4,5
25	8,5 ... 30	1,6 ... 5,4
30	9,5 ... 40	1,7 ... 7,2
35	10,5 ... 50	1,9 ... 9

Stack height (H) mm	Power absorption W	Shaft Power W Plus
12	4 ... 15	1,4 ... 5,3
16	5 ... 20	1,8 ... 7
20	6 ... 25	2,1 ... 8,8
25	7 ... 30	2,5 ... 10,5
30	8 ... 40	2,8 ... 14
35	9 ... 50	3,2 ... 17,5

Ventilation Units

05



Ventilation Blower

216



Axial Blower

217



**Axial/Tangential
Blower**

218



**Fan Blower
50 mm deep**

219



**Centrifugal Blower
to exhaust cooking vapours**

220



**Ventilation Unit
for Oven**

221

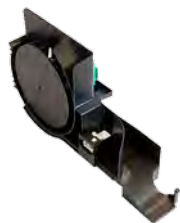

**Dishwasher Cooling
Ventilation Unit**

222



VENTILATION BLOWER

WITH SNAP-IN MOUNTING

PATENTED



Ventilation blower consisting of motor with fan, with an easy fastening system. Efficient and silent, it is suitable to be used in every ventilation and cooling solutions.

FEATURES

Easy mounting without tools

Forcing or suction fan available

Motor \varnothing 58

Special plastic flange with easy fastening system



OPTIONS

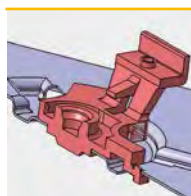

Snap-in mounting
example



Quick
connection 6.3



Snap-in
backmounting
solution

CUT OUT

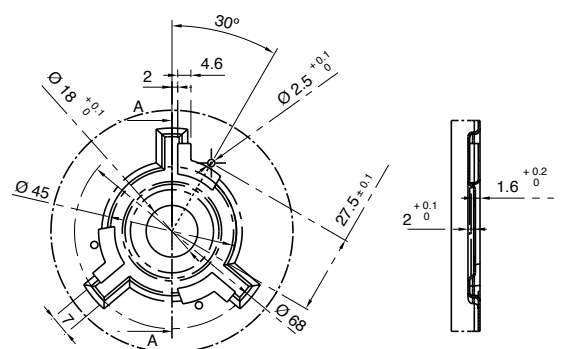



AXIAL BLOWER

FEATURES

Class of insulation: F

Motor \varnothing 58 with quick connection
6.3 mm + 4 blades-fan

Mounting system: fastening system
without tools

Endurance test 3000 h /120 °C



DRAWING

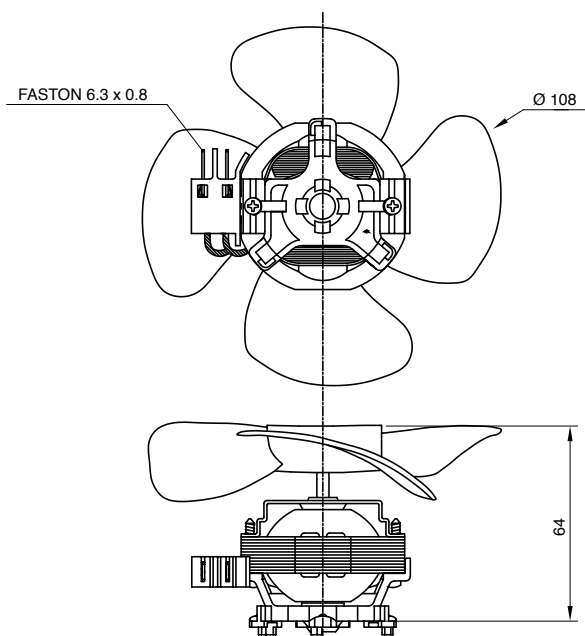



AXIAL/ TANGENTIAL BLOWER

FEATURES

Class of insulation: F/H

Motor \varnothing 58 + housing in fiber glass reinforced thermoplastic material
+ 7 blades-fan

Mounting system: self screwing

Endurance test 3000 h /120 °C

PATENTED



Designed for the built-in oven cooling, noiseless, it is the best compromise between costs and benefits. The axial design provide long-term stability and balance to the blower.



DRAWING

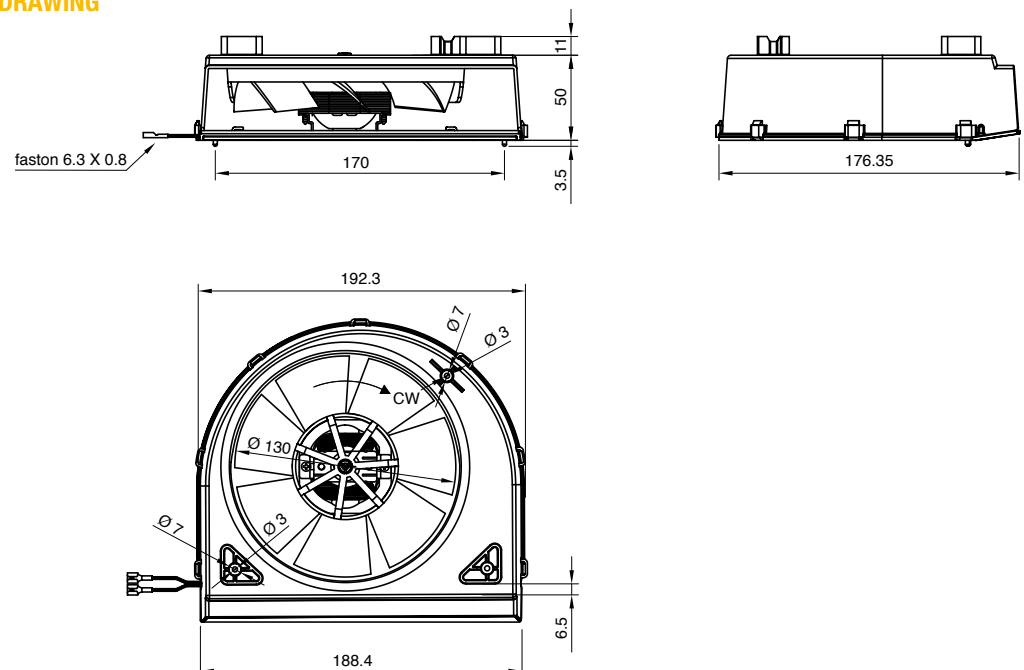



FAN BLOWER 50 MM DEEP

FEATURES

Reduced dimensions

Suitable for ambient temperature till 120 °C

Applications: oven ventilation

Class H version available

Blower output: between 70 m³/h and
100 m³/h (between 41 CFM and 59 CFM)



DRAWING

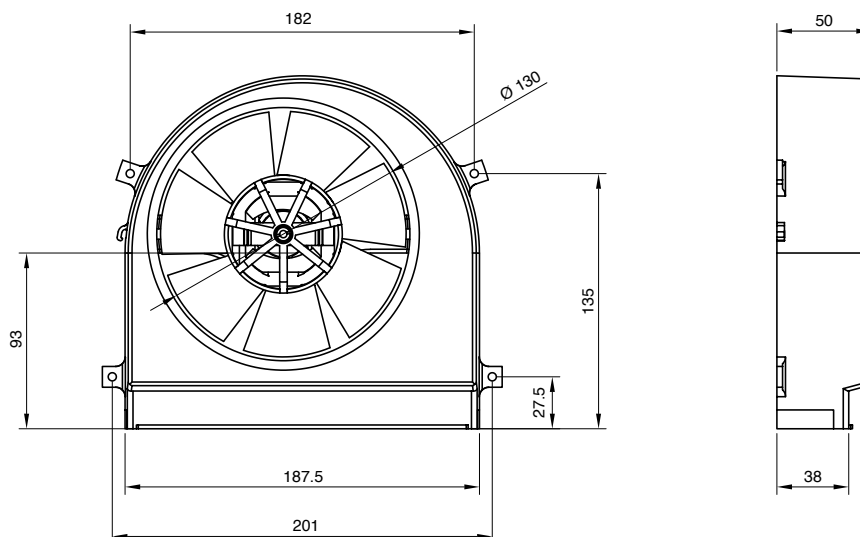

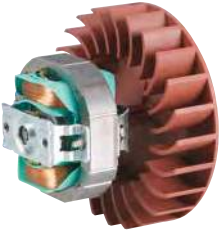

CENTRIFUGAL BLOWER

TO EXHAUST COOKING VAPOURS

FEATURES

- Class of insulation: F
- Motor Ø 58 + 24 blades-fan
- Mounting system: M4 Screws
- Endurance test 3000 h /120 °C

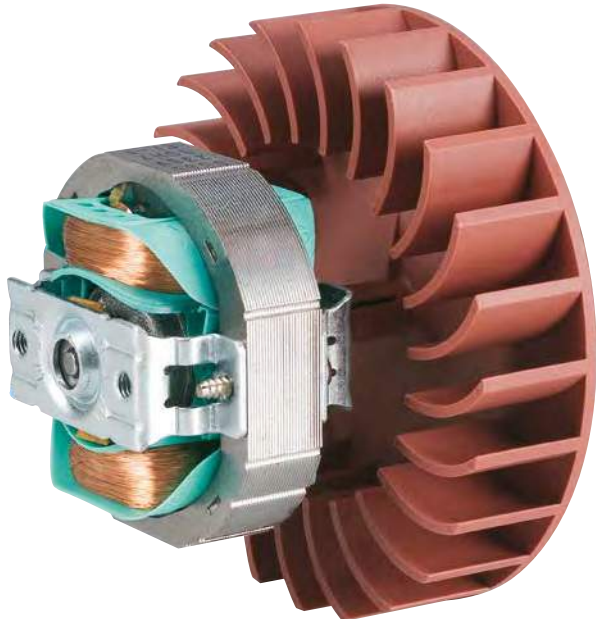

DRAWING

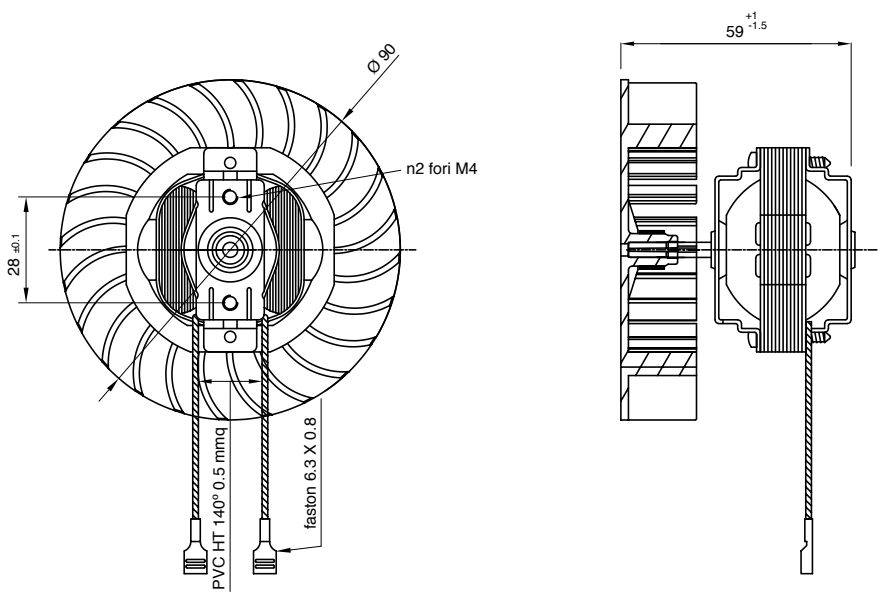



VENTILATION UNIT FOR OVEN

UP TO 900 MM SIZE

PATENTED



FEATURES

Suitable to cool down ovens' frontal door and electronic control

Suitable to exhaust cooking vapours

Class of insulation: F; H version also available

Motor Ø 58 + housing in fiber glass reinforced + 7-blades fan

Mounting system: screws

Life test: 5.000h/120 °C

Blower output: 90 m³/h

Height: 50-60 mm

Version for oven up to 600 mm available



DRAWING

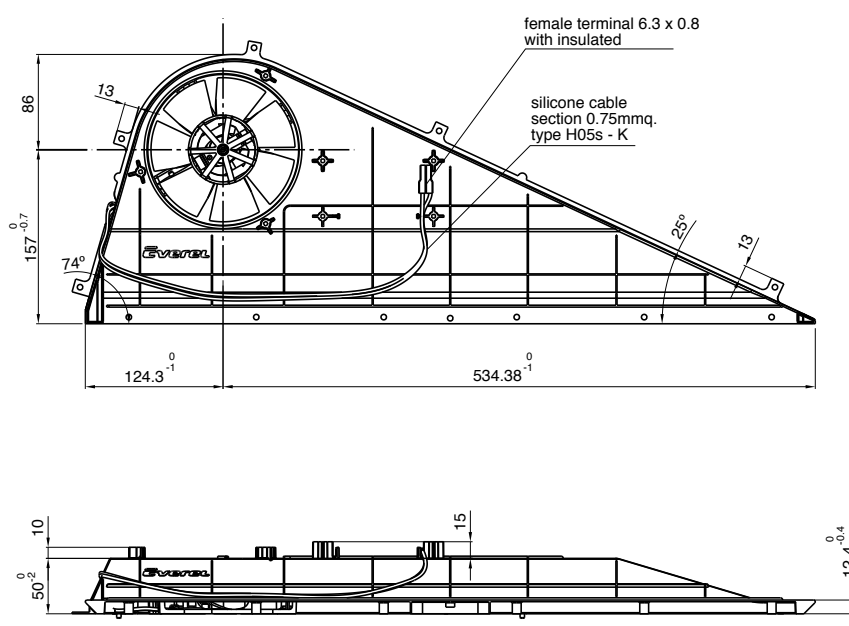

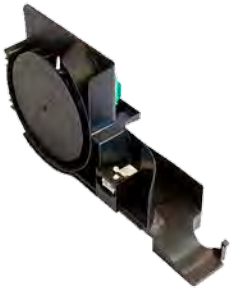

DISHWASHER COOLING VENTILATION UNIT

FEATURES

Suitable to cool down the outside of dishwasher's vat

It reduces drying time

Class of insulation: F; available also H version

Motor \varnothing 58 + 12-blades fan and plastic cage

Mounting system: screws

Life test: 5.000h/120 °C

Blower output: 45 m³/h

Height: 50-60 mm

PA 66 FG plastic housing

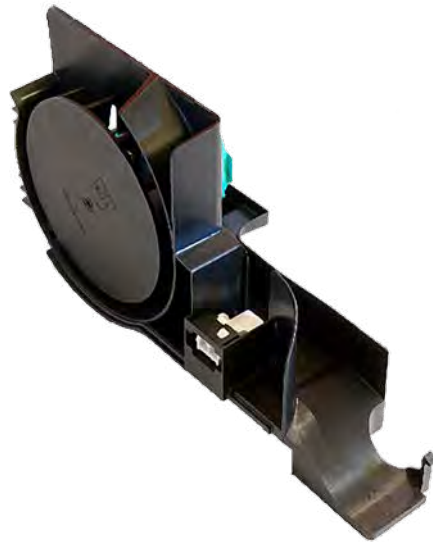

DRAWING

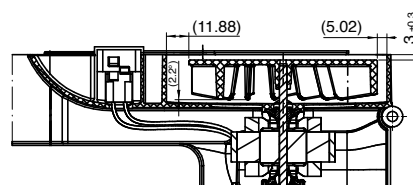
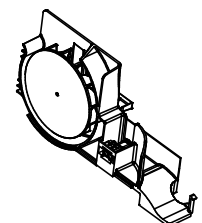
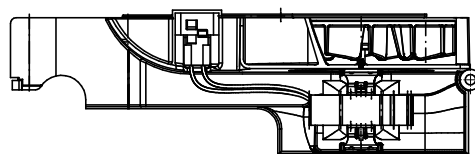
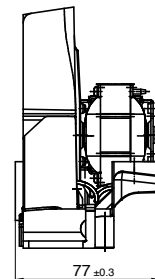
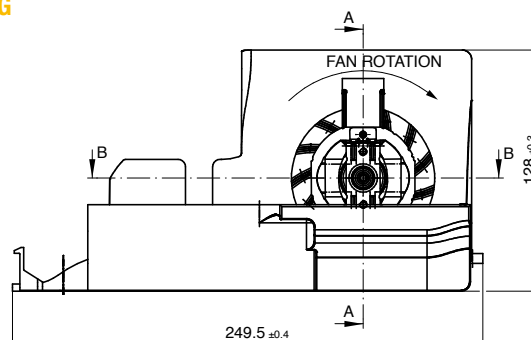

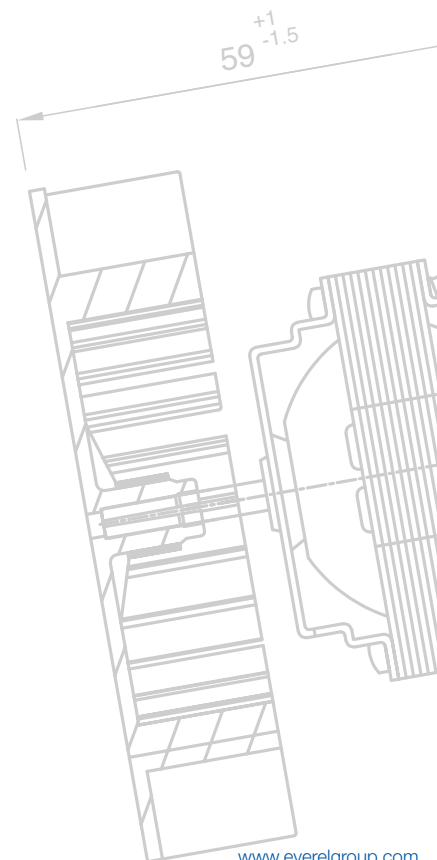
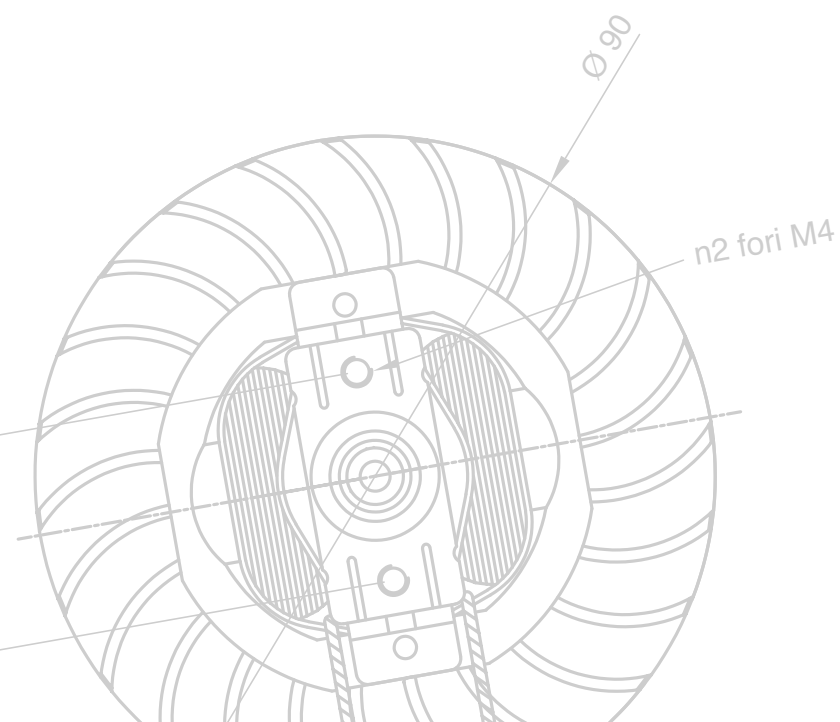
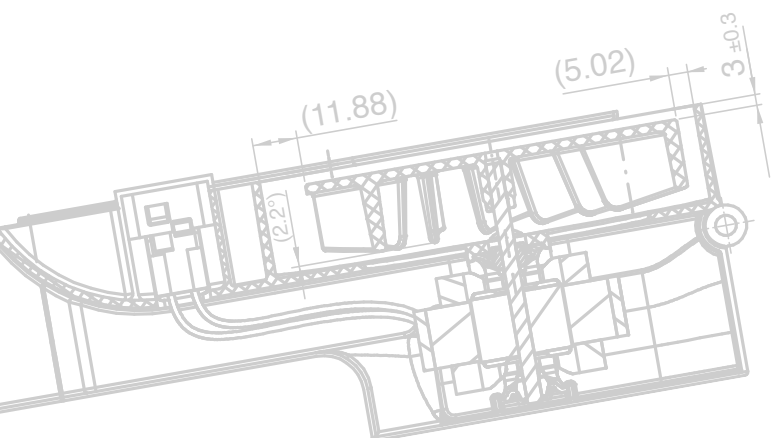
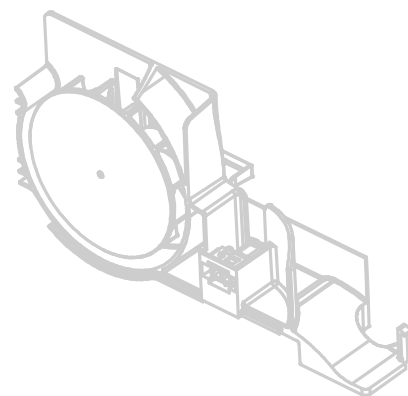
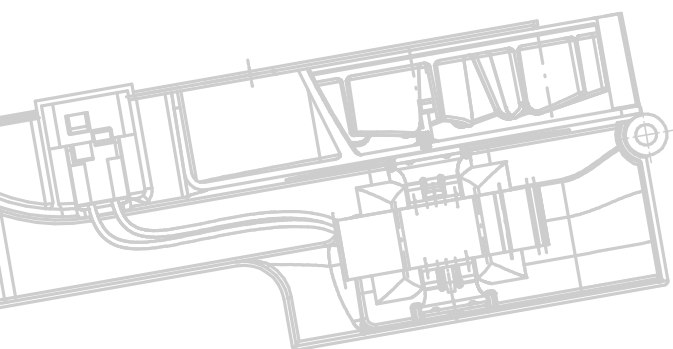
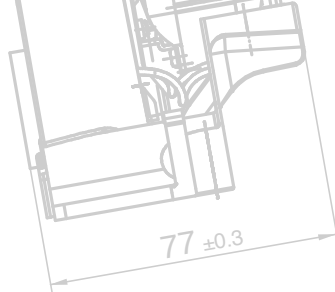
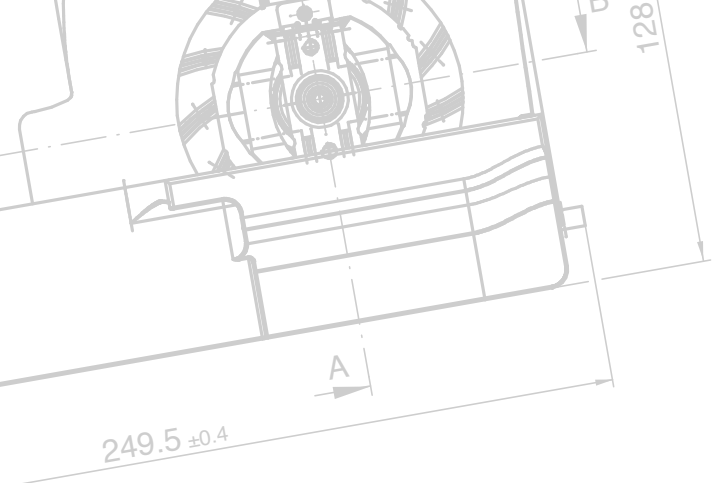

Power Connectors

06



STS

226



SFS

226



SST

227



SW

228



STF

230



SFO

231



SCM81

231

STS

10 A / 250 VAC EN 60320
 10 A / 250 VAC
 15 A / 125 VAC
 UL 498

STS3
 C14
 Class I
 T 70 °C

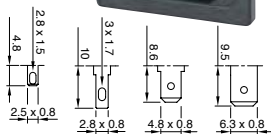

STS5
 C16
 Class I
 T 120 °C

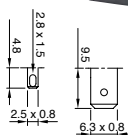

STS2
 C18
 Class II
 T 70 °C

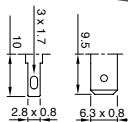

TYPICAL APPLICATIONS Coffee machine, appliance inlet for cold/warm conditions with/without earthing contact, for "snap in" fastening

WIRING DIAGRAMAS ■ 2-pole
 ■ 2-pole + earth

CUT OUT 27x20 mm

GWT 850 °C

GWT NO FLAME (<2sec) 750 °C on demand



CUT OUT

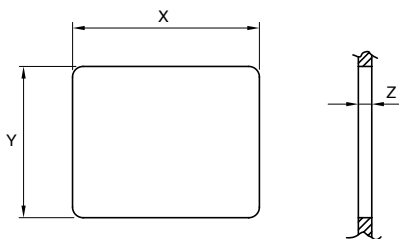

Z	X	Y
1 ... 1,8	27	20,0 +0,2
1,8 ... 3,0	27	20,2 +0,2

DRAWING

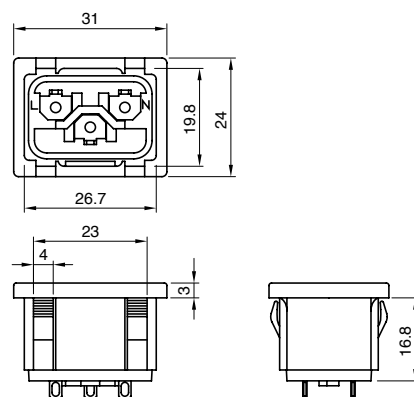

SFS

10 A / 250 VAC EN 60320
 10 A / 250 VAC
 15 A / 125 VAC
 UL 498

SFS2
 H
 Class II
 T 70 °C

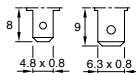

SFS3
 F
 Class I
 T 70 °C



TYPICAL APPLICATIONS Small appliances, appliance outlet for cold conditions with/without earthing contact, for "snap in" fastening

WIRING DIAGRAMAS ■ 2-pole
 ■ 2-pole + earth

CUT OUT 32x25 mm

GWT 850 °C

GWT NO FLAME (<2sec) 750 °C on demand



CUT OUT

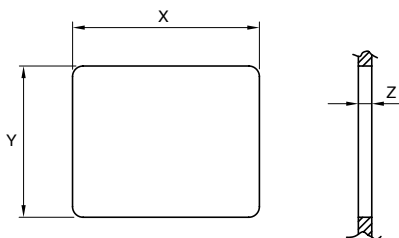

Z	X	Y
1 ... 1,8	32,5	25,0 +0,2
1,9 ... 3,0	32,5	25,2 +0,2

DRAWING

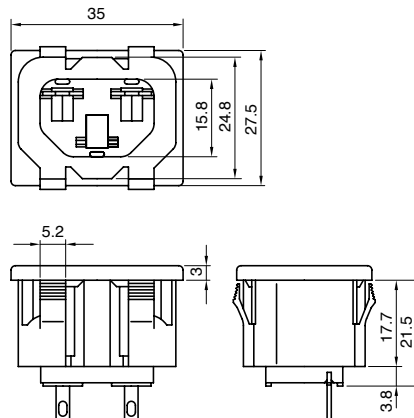

10 A / 250 VAC EN 60320 10 A / 250 VAC UL 498

TYPICAL APPLICATIONS	Small appliances, appliance inlet for cold conditions with/without earthing contact and 1 fuse-holder
WIRING DIAGRAMAS	<ul style="list-style-type: none"> 2-pole with fuse-holder 2-pole + earth with fuse-holder
CUT OUT	31x27 mm
GWFI	850 °C
GWIT	750 °C on demand



CUT OUT

SST...
C14
Class I
T 70 °C

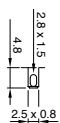

Mounting hole 90° countersink

DRAWING

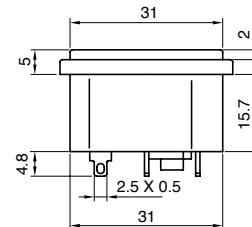
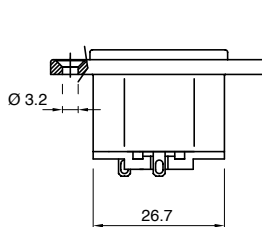
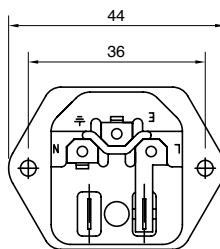

SST...
C14
Class I
T 70 °C

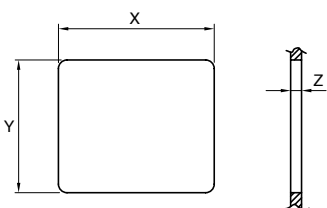
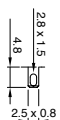

Z	X	Y
1 ... 1,8	31,3 ... 31,5	27,0 +0,2
1,9 ... 3,2	31,5 ... 31,7	27,0 +0,2

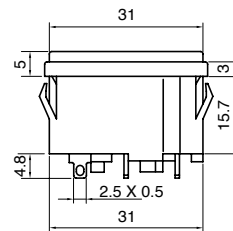
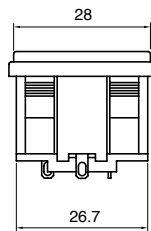
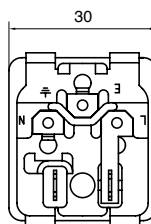

SST...
C18
Class II
T 70 °C

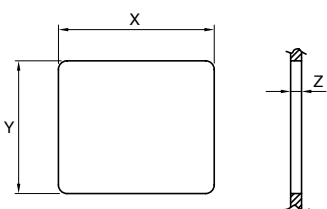

Z	X	Y
1 ... 1,8	31,3 ... 31,5	27,0 +0,2
1,9 ... 3,2	31,5 ... 31,7	27,0 +0,2

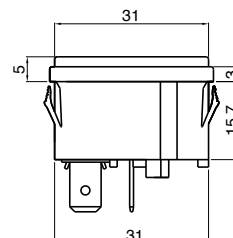
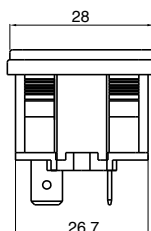
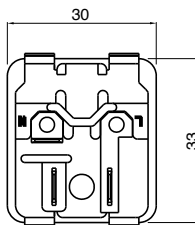

SW

10 A / 250 VAC EN 60320
6 A / 250 VAC UL 498
 Fuse max 6.3 A 250 VAC

TYPICAL APPLICATIONS Small appliances, appliance inlet for cold conditions with earthing contact, 1 or 2 fuse-holders
 For voltage selector

WIRING DIAGRAMAS ■ 2-pole + earth with fuse-holder slots

CUT OUT 56x28 mm

GWT 850 °C

GWT NO FLAME (<2sec) 750 °C on demand



SW.
 C14
 Class I
 T 70 °C



TC
 2.8 x 1.5

CUT OUT

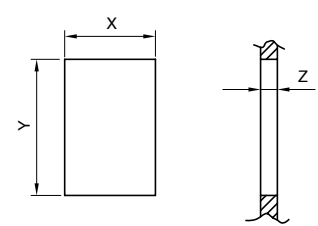

Z	X	Y
0,8 ... 2,0	55,9 ... 56,1	28,5 ... 28,7
2,1 ... 3,2	56,2 ... 56,4	28,5 ... 28,7

DRAWING

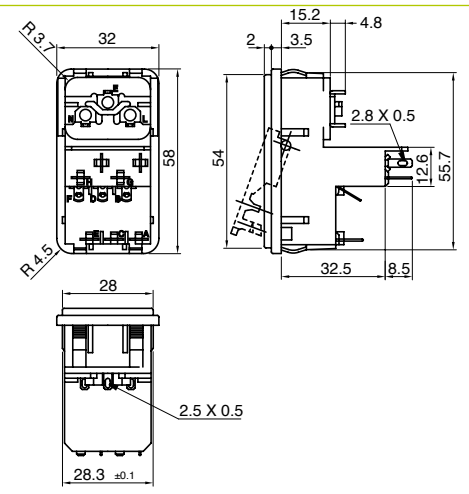

SW5.
 C14
 Class I
 T 70 °C



TC
 2.8 x 1.5

Mounting hole 90° countersink

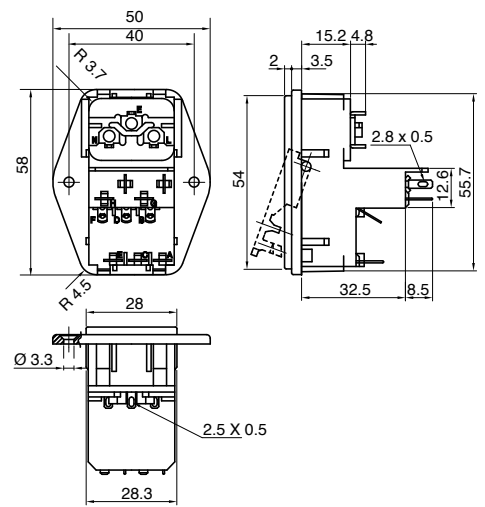

ACTUATING DEVICE FOR VOLTAGE SELECTOR

Accessories available for SW. and SW5.

SW950A1



↔	100V~	120V~	220V~	240V~
F - E	↔	↔	↔	↔
D - E	↔	↔	↔	↔
D - C	↔	↔	↔	↔
B - C	↔	↔	↔	↔
B - A	↔	↔	↔	↔

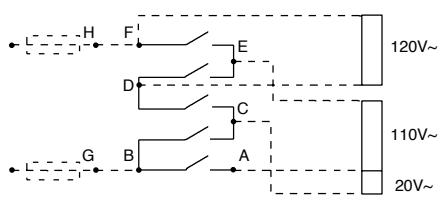

SW966A1



↔	100V~	120V~	230V~	240V~
F - E	↔	↔	↔	↔
D - E	↔	↔	↔	↔
D - C	↔	↔	↔	↔
B - C	↔	↔	↔	↔
B - A	↔	↔	↔	↔

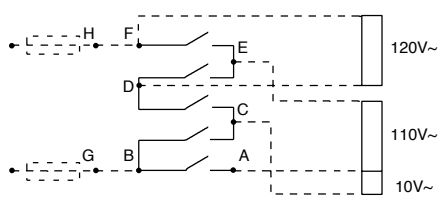

10 A / 250 VAC 6 A / 250 VAC
 EN 60320 UL 498

Fuse max 6.3 A 250 VAC

TYPICAL APPLICATIONS

Small appliances, appliance inlet for cold conditions with earthing contact, 1 or 2 fuse holders With cut out for switch

WIRING DIAGRAMAS

■ 2-pole + earth with fuse-holder slots

CUT OUT

56x28 mm

GWT

850 °C

GWT NO FLAME (<2sec)

750 °C on demand



SW10.

C14
 Class I
 T 70 °C



2.8 x 1.5

CUT OUT

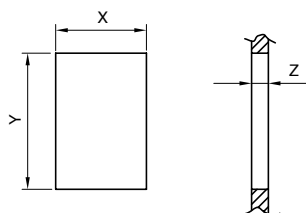

Z	X	Y
0,8 ... 2,0	55,9 ... 56,1	28,5 ... 28,7
2,1 ... 3,2	56,2 ... 56,4	28,5 ... 28,7

DRAWING

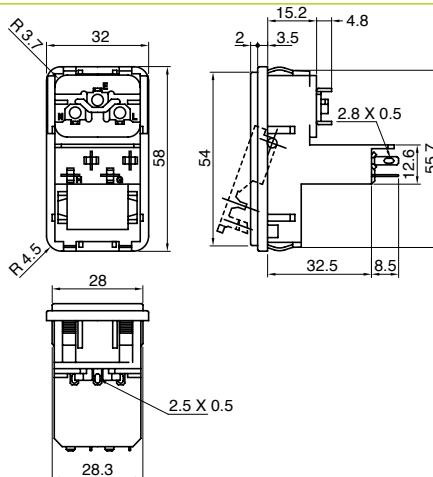

SW15.

C14
 Class I
 T 70 °C



2.8 x 1.5

Mounting hole 90° countersink

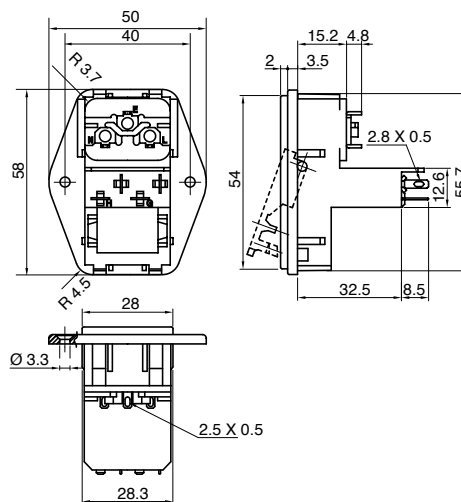

FUSE-HOLDERS

Accessories available for the whole SW series



SW900A1

USA fuse-holders
 Fuse-holders dimensions: 6.3 x 32 mm



SW900A1

European fuse-holders
 Fuse-holders dimensions: 5 x 20 mm
 Fuse max 6.3 A 250 VAC

STF

10 A / 250 VAC EN 60320
 10 A / 250 VAC
 15 A / 125 VAC
 UL 498

TYPICAL APPLICATIONS	Ironing systems, appliance inlet for cold/warm conditions with earthing contact, mounting hole with 90° countersink
WIRING DIAGRAMAS	2-pole + earth
CUT OUT	screw fixing
GWT	850 °C
GWT NO FLAME (<2sec)	750 °C on demand



CUT OUT

DRAWING

STF...

C14
 Class I
 T 70 °C



Mounting hole 90° countersink
 On small side

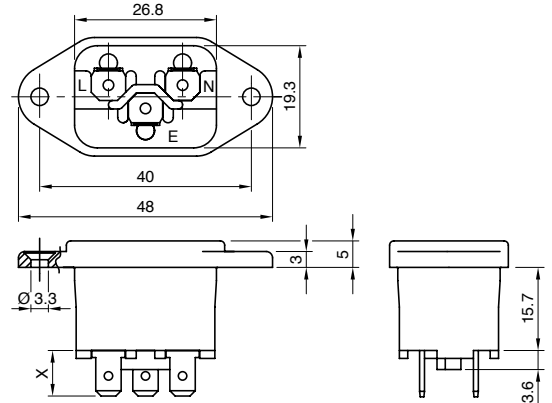
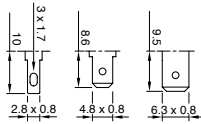

STF...

C16
 Class I
 T 120 °C



Mounting hole 90° countersink
 On small side

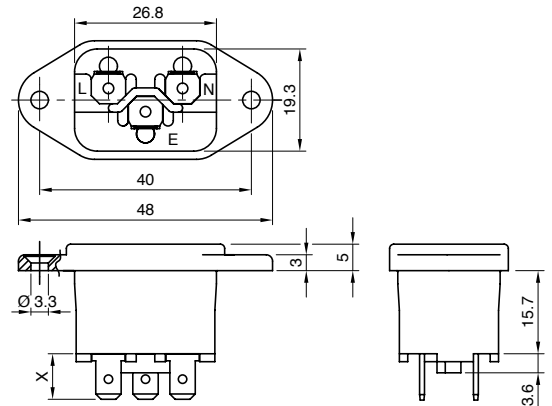
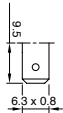

STF...

C16
 Class I
 T 120 °C



Mounting hole 90° countersink
 On large side

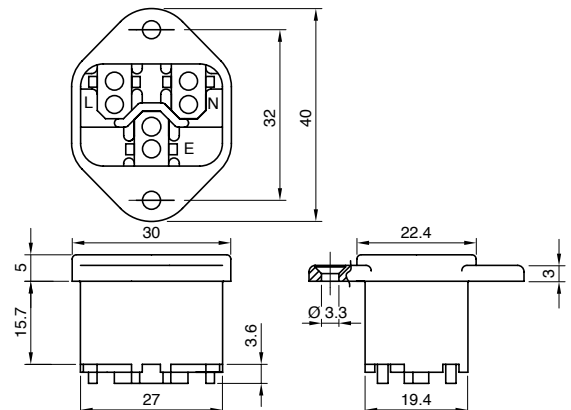
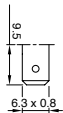

SFO

10 A / 250 VAC
EN 60320

10 A / 250 VAC
15 A / 125 VAC
UL 498

TYPICAL APPLICATIONS	Computer and peripherals, connector for cold/warm conditions with earthing contact, rewirable
WIRING DIAGRAMAS	Power inlet connector 2-pole + earth
CUT OUT	With electric wire
GWT	850 °C
GWT NO FLAME (<2sec)	750 °C on demand



SFO 430

C13
Class I
T 70 °C



Screw terminals

SFO 440

C13
Class I
T 70 °C



Screw terminals

SFO 550

C15
Class I
T 120 °C



Screw terminals

SCM81

10 A / 250 VAC
CEI 23-50 - II Ed. 2007
+V1:2008 +V2:2011

TYPICAL APPLICATIONS	Bathroom furniture
WIRING DIAGRAMAS	<ul style="list-style-type: none"> ■ Italian 2-pole ■ Italian 2-pole + earth
CUT OUT	27x12 mm
GWT	850 °C
GWT NO FLAME (<2sec)	750 °C on demand



RoHS
RoHS compliant

CUT OUT

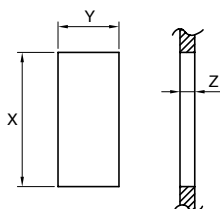

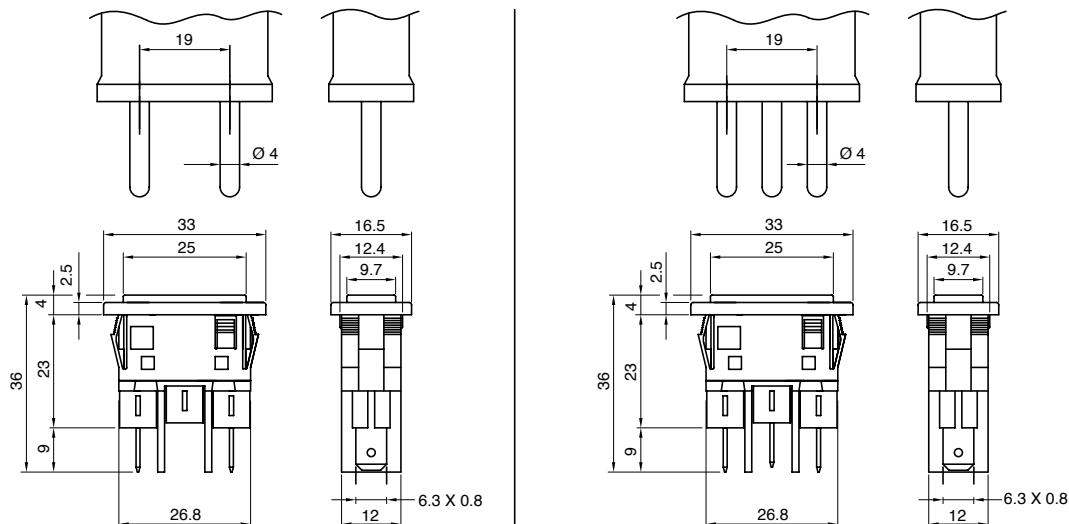

Z	X	Y
0,75 ... 1,25	12,4	$27,3^{+0,0}_{-0,1}$
1,25 ... 2,0	12,4	$27,5^{+0,0}_{-0,1}$
2,0 ... 3,0	12,4	$27,9^{+0,0}_{-0,2}$
3,0 ... 4,0	12,4	$28,1^{+0,0}_{-0,2}$

DRAWING



Approvals and Ratings

Almost all Everel switches have been tested and approved according to EN61058-1 standard, they are identified with the European approval logo , they are also in conformity with UL1054 and C22.2 - 55 identified with   logos. Every approval is available on the web site www.everelgroup.com.

Some of our switches use materials that comply with EN 60335 GWT NO FLAME (< 2sec), other series this feature is available on demand.

Signal lights are approved according to VDE 0710, most Encoders and Selectors are approved according to EN 61058-1, Motors and Ventilation Units are approved according to EN60335-1, Power Connectors are approved according to EN 60320-1 with exception of SCM 81 which is approved according to CEI 23-50.



Cycle No. life endurance

Most Everel products reach the 50.000 electromechanical cycles, this is indicated by the abbreviation 5E4; if it is not mentioned the operating ratings are meant to be approved for an electro-mechanical life endurance of 10.000 cycles.



RoHS directive and REACH regulation

All Everel products are made using materials and procedures conforming to RoHS 2011/65/EU directive concerning restrictions on the use of hazardous substances and the handling of waste of electric and electronic devices. Our products are also compliant with REACH regulation EC No.1907/2006.



Ambient temperature

The T125 marking means that the item is approved in conformity with EN61058-1 for a max ambient temperature of 125°C (T stays for Temperature and the number stays for the maximum ambient temperature).

Obviously, the item performances can be extremely reduced or compromised if the product is used outside the admitted temperature range, in very moist or in corrosive environments.



IP- Protection Degree

The protection degree against solid or liquid elements penetration (IP degree) refers to the actuating side of the switch. After the assembly of the items the customer is responsible for its tightness and its enduring performances and features.



GAP between the contacts

Most Everel items (in this catalogue) show an air insulation gap among the contacts > 3 mm, and are suitable to disconnect the appliance from power supply.

The symbol μ identifies the items with a gap between the contacts < 1,5 mm.



CE marking

Our items meet the requirement of the Low voltage Directive 2014/35/EU with the addition of directive relating to electromagnetic compatibility 2014/30/EU.



Operating conditions

The products functional parameters are guaranteed with the operative conditions illustrated by the reference standard (EN 61058-1 and UL 1054 or UL 61058 on demand from 06/2015).

We recommend to use our items only after a period of at least 24 hours at a minimum temperature of 16°C, in order to avoid possible inconveniences due to the hardening of the plastic material.



Data modification in this catalogue

We reserve the right to introduce any improving changes on the products and on the projects that we consider necessary. Drawings and pictures showed in the catalogue do not have to be considered as binding. Item samples and drawings are available on demand for detailed dimensional and aesthetical evaluation of the product. Further information and updates are available on www.everelgroup.com.



© Copyright 2017 - Property of Everel Company
All rights reserved, any reproduction (including extracts) require a written agreement by Everel Group S.p.A.

Printed in February 2017
Graphic: Imprimatur ADV - Verona



- Headquarter
- Production Site
- Sales Network



Everel Group S.P.A.

[Headquarter - Production Site]
Via Cavour, 9
37067 Valeggio sul Mincio (VR) - Italy
tel. +39 045 6313711
fax +39 045 6313730

Dreefs GmbH

[Production Site]
Ernst-Dreefs-Straße 7
96364 Marktrodach - Germany
tel. +49 9261 9610
fax +49 9261 961248

Everel Romania S.r.l.

[Production Site]
Calea Timisorii 109
Lipova - Arad - Romania
tel. +40 257 563087
fax +40 257 563086

www.everelgroup.com

